



AGENDA OF THE REGULAR SESSION OF THE
COUNCIL OF THE CITY OF WASHINGTON, IA
TO BE HELD IN THE
COUNCIL CHAMBERS
215 E. WASHINGTON STREET
AT 6:00 P.M., TUESDAY, August 16, 2022

To attend the meeting via Zoom go to:

<https://us02web.zoom.us/j/84413261389?pwd=Sy9VMjg1dHpoYkkwTzFPTy84aUF2dz09>

Meeting ID: 844 1326 1389

Passcode: 6536584

Call to Order

Pledge of Allegiance

Roll call

Agenda for the Regular Session to be held at 6:00 P.M., Tuesday, August 16, 2022 to be approved as proposed or amended.

Consent:

1. Council Minutes August 2, 2022
2. Bolton & Menk, Runway 18/36 Lighting, \$3,784.00
3. Bolton & Menk, Runway 18/36 PAPI and REILs, \$962.50
4. Bolton & Menk, Fuel System Repair, \$6,523.25
5. East Central Iowa Council of Governments, CDBG Rehabilitation Grant Administration, \$4,837.50
6. FOX Strand, 2021 Water Main Improvements Final Design, \$860.00
7. FOX Strand, Highway 1 Development Concept Design, \$1,580.00
8. FOX Strand, Wastewater Treatment Plant Consultation; IRE Pretreatment Agreement, \$116.00
9. Iowa Municipalities Workers' Compensation Association, Installment 2 Work Comp. Premium 22-23, \$6,909.00
10. Kevin Olson, City Attorney, June and July Legal Services, \$2,103.72
11. Department Reports

SPECIAL EVENT REQUESTS

- Hocus Pocus in the Park
- S.N.O.W. Holiday Events
- August Nuisance Update
- Mama Llama's Barn Grand Opening September 1, 2022 (*added item*)

PRESENTATION FROM THE PUBLIC – Please limit comments to 3 Minutes

CLAIMS & FINANCIAL REPORT

- Claims for August 16, 2022
- July Financials

NEW BUSINESS

1. **Public Hearing** on 2022 Water Main Improvement Project
2. Discussion and Consideration of a Resolution Adopting Plans, Specifications, Form of Contract, and Estimate of Costs for the 2022 Water Main Improvement Project
3. Discussion and Consideration of a Resolution Authorizing Levy, Assessment, and Collection of Costs to the Washington County Treasurer
4. Discussion & Consideration of Main Street Washington Challenge Grant Application Letter of Support (Renovation of Koller Plus Building 206 S. Iowa Ave.)
5. Discussion and Consideration of a Resolution Supporting a Grant Application to the Washington County Riverboat Foundation – Wellness Park Playground Project
6. Discussion and Consideration of Preliminary Plat for Wiley Subdivision Third Addition
7. Discussion and Consideration of Site Plan for Wiley Subdivision Third Addition
8. Discussion and Consideration of Notice to Proceed (MSJ/Country Club View Subdivision Plat 1 Project)
9. Discussion and Consideration of a Resolution Appointing Paying Agent, Note Registrar, and Transfer Agent, Approving the Paying Agent and Note Registrar and Transfer Agent Agreement and Authorizing the Execution of the Agreement
10. Discussion and Consideration of a Resolution Amending the Resolution Approving and Authorizing a Form of Loan Agreement and Authorizing and Providing for the Issuance, and Levying a Tax to Pay the Notes; Approval of the Tax Exemption Certificate and Continuing Disclosure Certificate
11. Discussion and Consideration of Pay Application No. 3 (NLW Subdivision – Plat 2)
12. Discussion and Consideration of Pay Application No. 8 (West Buchanan Street Project)
13. Discussion and Consideration of Pay Application No. 1 (East Adams Street Reconstruction Project)
14. Discussion and Consideration of the Third and Final Reading of an Ordinance Amending Chapter 70 Traffic Code Enforcement Procedures – Parking Violations, Impounding Vehicles
15. Discussion and Consideration of the Second Reading of an Ordinance Amending Chapter 69.08 Parking Regulations – No Parking Zones

16. Discussion and Consideration of the First Reading of an Ordinance Amending Chapter 69 Parking Regulations – Parking for Certain Purposes Illegal, Parking Prohibited, No Parking Zones, Truck Parking Limited

17. Discussion and Consideration of the First Reading of an Ordinance Amending Chapter 69.13 Parking Regulations – Snow Ban Parking and Snow Emergency

DEPARTMENTAL REPORTS

Police Department

City Attorney

City Administrator

MAYOR & COUNCILPERSONS

Jaron Rosien, Mayor

Illa Earnest

Steven Gault

Bethany Glinsmann

Elaine Moore

Fran Stigers

Millie Youngquist

ADJOURNMENT

CITY OF WASHINGTON
Council Minutes 8-2-2022

The Council of the City of Washington, Iowa, met in Regular Session in the Council Chambers, 215 East Washington Street on Tuesday, August 2, 2022, at 6:00 p.m. Mayor Rosien in the chair.

On roll call present: Earnest, Gault, Glinsmann, Moore, Stigers, and Youngquist. Absent: none.

Motion by Gault, seconded by Earnest, that the agenda for the Regular Session to be held at 6:00 p.m., Tuesday, August 2, 2022, be approved as amended striking item 9 of new business Pay App. No. 6 West 5th/Lexington. Motion carried.

Consent:

1. Council Minutes July 19, 2022
2. Garden & Associates, General Engineering, \$551.98
3. Garden & Associates, NLW Subdivision Phase 2, \$4,167.58
4. Garden & Associates, 2022 Sealcoat Improvements, \$329.50
5. Garden & Associates, Buchanan Street Paving Project, \$11,014.28
6. Garden & Associates, Reconstruction of East Adams, \$4,149.33
7. Morning Sun Farm Implement, Inc., Wastewater Treatment Plant Tractor, \$48,275.00
8. Smith & Loveless Inc., Everlast Pump Station, ARPA Funded, \$78,737.00
9. Swift & Swift LLC, Contractor Final Payment Request Housing Rehabilitation Program, \$16,650.00
10. Swift & Swift LLC, Contractor Payment Request Housing Rehabilitation Program, \$15,300.00
11. Corner Stop DNP LLC, 100 E. Madison, Class C Beer, Class B Wine, Class B Native Wine, Living Quarters (renewal)
12. Mi Pueblo Real #2, 1021 W. Madison, Class C Liquor, Sunday Sales (renewal)
13. Department Reports

Motion by Stigers, seconded by Gault, to approve consent items 1-13. Motion carried.

The Mercantile request for a food truck was discussed and will follow the administrative process for review. No action taken.

Presentation from the public: Councilor Gault spoke of statements made at the previous council meeting and he believed an apology would be appropriate. Councilor Glinsmann clarified her comments and said she wanted to ensure a welcoming environment. Michael Crossett spoke of parking in the 500 block of North Iowa being a problem due to rental properties and the need for off-street parking, he also requested a four-way stop by the underpass or to make the temporary school stop signs on North 2nd by Stewart School permanent. Don Hughes thanked council for the parking consideration on East Main Street and said there is enough space for traffic there, he asked why changes are being pursued. Don Bayliss asked why parking changes are being pursued on East Main and said there is adequate room as-is and some properties do not have alley access for parking. Mike Murphy spoke of parking issues on South Ave. E, concerns with the West Buchanan project and erosion control. Brent Wilson said parking is not a problem on

Highland Avenue and provided photos to city council. Lisa Murphy said she is not in favor of parking on one side of North Iowa Ave. and that off-street parking needs to be provided for rental properties in the area. Laura Walsh said the parking problem in the 500 block of North Iowa stems from rental properties and is not in favor of parking on one side of the street. Mayor Rosien explained that no changes are proposed tonight for Iowa, Marion, Main, 2nd, or Highland, and are under further review. Councilor Moore said more research needs to be done to develop a better action plan. Ashley Wilson asked when the other streets will be considered for parking changes.

Claims for August, 2022 were presented by Finance Director Kelsey Brown.

Motion by Gault, seconded by Moore, to approve the claims for August 2, 2022. Motion carried.

Financial Reports for June 2022 were presented by Finance Director Brown.

Motion by Gault, seconded by Stigers, to approve the June 2022 Financial Report. Motion carried.

Motion by Gault, seconded by Moore, to approve a Resolution Setting a Public Hearing on Plans, Specifications, Estimate of Cost and Form of Contract, and Setting a Date for Receiving of Bids for the 2022 Water Main Project. Engineer Steve Soupier was in attendance to answer questions. Roll call on the motion: Ayes: Gault, Glinsmann, Moore, Stigers, Youngquist and Earnest. Nays: none. Motion carried. **(Resolution 2022-095)**

Motion by Stigers, seconded by Youngquist, to approve a Resolution Authorizing Levy, Assessment, and Collection of Costs to the Washington County Treasurer. Roll call on the motion: Ayes: Gault, Glinsmann, Moore, Stigers, Youngquist and Earnest. Nays: none. Motion carried. **(Resolution 2022-096)**

Motion by Earnest, seconded by Gault, to approve a Resolution Setting a Revised General Fund Balance Policy and Authorizing Interfund Transfers. Roll call on the motion: Ayes: Gault, Glinsmann, Moore, Stigers, Youngquist and Earnest. Nays: none. Motion carried. **(Resolution 2022-097)**

Motion by Gault, seconded by Moore, to approve a Resolution Authorizing Fiscal Year End 2022 Transfers. Roll call on the motion: Ayes: Gault, Glinsmann, Moore, Stigers, Youngquist and Earnest. Nays: none. Motion carried. **(Resolution 2022-098)**

Motion by Moore, seconded by Gault, to approve a Resolution Allocating Excess Municipal Grant Funding. Roll call on the motion: Ayes: Gault, Glinsmann, Moore, Stigers, Youngquist and Earnest. Nays: none. Motion carried. **(Resolution 2022-099)**

Consultant Services Bids Received for Fall 2022 Goal Setting:

- Callahan Municipal Consultants \$1,500
- Mark Jackson \$1,320

Motion by Gault, seconded by Stigers, to Hire Mark Jackson for the Fall 2022 Goal Setting Session. Motion carried.

Motion by Gault, seconded by Moore, to Approve Change Order No. 1 for West 5th/Lexington Project for \$5,992. Motion carried.

Motion by Moore, seconded by Gault, to Approve Change order No. 2 for West 5th/Lexington Project for \$2,995. Motion carried.

Motion by Gault, seconded by Stigers, to approve Second Reading of an Ordinance Amending Chapter 70 Traffic Code Enforcement Procedures – Parking Violations, Impounding Vehicles. Roll call on the motion: Ayes: Gault, Glinsmann, Moore, Stigers, Youngquist and Earnest. Nays: none. Motion carried.

Motion by Gault, seconded by Stigers, to approve First Reading of an Ordinance Amending Chapter 69.08 Parking Regulations – No Parking Zones. Roll call on the motion: Ayes: Gault, Glinsmann, Moore, Stigers, Youngquist and Earnest. Nays: none. Motion carried.

Council went into workshop to discuss Amending Chapter 69 Parking Regulations – Parking for Certain Purposes Illegal, Parking Prohibited, No Parking Zones, and Truck Parking Limited. Police Chief Jim Lester gave a presentation with photos to show the areas for consideration. Areas discussed include South C Avenue and South B Avenue from Madison to Tyler, North 4th from Main Street to East 5th, West Van Buren Street from South Iowa Avenue to South Avenue D, no parking where yellow paint or official signs are posted, truck and trailer parking, travel-trailer and motorhome parking. No action was taken.

In workshop, council also discussed Amending Chapter 69 Parking Regulations – Snow Bank Parking and Snow Emergency. Police Chief Jim Lester provided suggestions from the parking committee. The snow ban parking would be in effect from November 1 to April 1 to allow for safe snow removal operations. Fines for violations shall be \$50. No action was taken.

Motion by Stigers, seconded by Gault, to go into closed session per Iowa Code 21.5(1)(i) – Six-Month Review of City Administrator Deanna McCusker at 7:50 p.m. Roll call on the motion: Ayes: Gault, Glinsmann, Moore, Stigers, Youngquist and Earnest. Nays: none. Motion carried.

Motion by Earnest, seconded by Moore, to go back into regular session at 8:17 p.m. Roll call on the motion: Ayes: Gault, Glinsmann, Moore, Stigers, Youngquist and Earnest. Nays: none. Motion carried.

Motion by Glinsmann, seconded by Gault, to approve a six-month wage increase of \$5,000 retroactive as of July 1, 2022 for City Administrator McCusker. Motion carried.

Departmental reports were presented.

Motion by Stigers, seconded by Gault, that the Regular Session held at 6:00 p.m., Tuesday, August 2, 2022, is adjourned at 8:25 p.m.

Sally Y. Hart, City Clerk



Real People. Real Solutions.

Please Remit To: Bolton & Menk, Inc.
 1960 Premier Drive | Mankato, MN 56001-5900
 507-625-4171 | 507-625-4177 (fax)

Payment by Credit Card Available Online at www.Bolton-Menk.com
 To Ensure Proper Credit, Provide Invoice Numbers with Payment

City of Washington
 Washington Airport Commission
 Kevin Erpelding, Chairman
 215 East Washington
 Washington, IA 52353

July 29, 2022
 Project No: 0T5.126255
 Invoice No: 0294957
 Client Account: WASHINGT_CI_IA

Washington/Runway 18/36 Lighting

Construction (002)

Professional Services

	Hours	Amount	
Administrative	4.50	382.50	
Design Engineer	4.50	531.00	
Project Manager	16.00	2,762.50	
Graduate Engineer	1.00	108.00	
Totals	26.00	3,784.00	
Total Labor			3,784.00
			Total this Task \$3,784.00
			Total this Invoice \$3,784.00

301-6-6020 6716

002-6-2080 _____ Initials ghd

EXP. Runway 18-36 Lighting

Vender # _____ Date Rec. 8-11-2022

Due Date _____ Inv # _____



Real People. Real Solutions.

Please Remit To: Bolton & Menk, Inc.
1960 Premier Drive | Mankato, MN 56001-5900
507-625-4171 | 507-625-4177 (fax)

Payment by Credit Card Available Online at www.Bolton-Menk.com
To Ensure Proper Credit, Provide Invoice Numbers with Payment

City of Washington
Washington Airport Commission
Kevin Erpelding, Chairman
215 East Washington
Washington, IA 52353

July 29, 2022
Project No: 0T5.126418
Invoice No: 0294959
Client Account: WASHINGT_CI_IA

Washington/Runway 18/36 PAPI and REILs

Construction (002)

Professional Services

	Hours	Amount	
Project Manager	5.50	962.50	
Totals	5.50	962.50	
Total Labor			962.50
			Total this Task \$962.50
			Total this Invoice \$962.50

301-6-6020-6716
~~002-6-2080~~ Initials Kit
EXP. REILS
Vender # _____ Date Rec. 8-11-2022
Due Date _____ Inv # _____



Real People. Real Solutions.

Please Remit To: Bolton & Menk, Inc.
1960 Premier Drive | Mankato, MN 56001-5900
507-625-4171 | 507-625-4177 (fax)

Payment by Credit Card Available Online at www.Bolton-Menk.com
To Ensure Proper Credit, Provide Invoice Numbers with Payment

City of Washington
Washington Airport Commission
Kevin Erpelding, Chairman
215 East Washington
Washington, IA 52353

July 29, 2022
Project No: 0T5.125319
Invoice No: 0294955
Client Account: WASHINGT_CI_IA

Washington Airport/Fuel System Repair

Refurbish and Link 2 Existing 10K Gallon Tanks

Design and Construction (001)

Fee			
Total Fee	48,500.00		
Percent Complete	58.45	Total Earned	28,348.25
		Previous Fee Billing	21,825.00
		Current Fee Billing	6,523.25
		Total Fee	6,523.25
		Total this Task	\$6,523.25
		Total this Invoice	\$6,523.25

301-6-6070-6705
 002-6-2080 _____ Initials QET
 EXP. Fuel Farm
 Vender # _____ Date Rec. 8-11-2022
 Due Date _____ Inv # _____



EAST CENTRAL IOWA
COUNCIL OF GOVERNMENTS
YOUR REGIONAL PLANNING AGENCY

Invoice

Date	Invoice #
7/29/2022	9801

700 16th Street NE, Suite 301
Cedar Rapids, IA 52402

Phone #	Fax #
319-289-0057	319-365-9981

Bill To
CITY OF WASHINGTON PO BOX 516 WASHINGTON IA 52353

Approved by: 

Quantity	Description	Rate	Amount
64.5	CDBG REHAB GRANT ADMINISTRATION	75.00	4,837.50
Please remit payment within 30 days.		Total	\$4,837.50



FOX Strand
 414 South 17th Street, Suite 107
 Ames, IA 50010-8106
 (515) 233-0000

Invoice

Deanna McCusker
 City Administrator
 City of Washington
 City Hall
 215 East Washington Street
 Washington, IA 52353

August 10, 2022
 Project No: 7046.011
 Invoice No: 0186540

Professional Services: July 1, 2022 through July 31, 2022

Project	7046.011	2021 Washington Water Main Improvements - Final Design	
Fee			
Total Fee	74,100.00		
Percent Complete	100.00	Total Earned	74,100.00
		Previous Fee Billing	74,100.00
		Current Fee Billing	0.00
		Total Fee	0.00
		Total this Project	0.00

Contract Amount 74,100.00

Total Billings to Date 74,100.00

Project	7046.012	2021 Washington Water Main Improvements - CDBG Grant Additional Services	
		Total this Project	0.00

Project	7046.013	2021 Washington Water Main Improvements- Permitting	
		Total this Project	0.00

Project	7046.014	2021 Washington Water Main Improvements - Bidding	
Fee			
Total Fee	8,600.00		
Percent Complete	18.00	Total Earned	1,548.00
		Previous Fee Billing	688.00
		Current Fee Billing	860.00

Project	7046.011	Washington Water Main - Final Design	Invoice	0186540
Total Fee				860.00
Total this Project				\$860.00

Project	7046.015	2021 Washington Water Main Improvements - Easements		
Total this Project				0.00

Project	7046.016	2021 Washington Water Main Improvements - Property Survey		
Fee				
Total Fee		14,000.00		
Percent Complete		0.00	Total Earned	0.00
			Previous Fee Billing	0.00
			Current Fee Billing	0.00
Total Fee				0.00
Total this Project				0.00

Contract Amount 14,000.00

Total Billings to Date 14,000.00

Project	7046.017	2021 Washington Water Main Improvements - Topographic Survey		
Fee				
Total Fee		21,700.00		
Percent Complete		100.00	Total Earned	21,700.00
			Previous Fee Billing	21,700.00
			Current Fee Billing	0.00
Total Fee				0.00
Total this Project				0.00

Contract Amount 21,700.00

Total Billings to Date 21,700.00

Project	7046.018	2021 Washington Water Main Improvements - Construction Administration		
Fee				
Total Fee		69,200.00		
Percent Complete		0.00	Total Earned	0.00
			Previous Fee Billing	0.00

TERMS: Payment is due within 30 days of the date on this invoice.

Please Remit Payment To: FOX Strand 414 South 17th Street, Suite 107 Ames, Iowa 50010-8106 515-233-0000

Project	7046.011	Washington Water Main - Final Design	Invoice	0186540
		Current Fee Billing	0.00	
		Total Fee		0.00
		Total this Project		0.00

Project	7046.019	2021 Washington Water Main Improvements - Post Construction/Record Drawings		
Fee				
Total Fee		7,600.00		
Percent Complete		0.00	Total Earned	0.00
			Previous Fee Billing	0.00
			Current Fee Billing	0.00
		Total Fee		0.00
		Total this Project		0.00

Project	7046.020	2021 Washington Water Main Improvements - Construction Staking		
		Total this Project		0.00
		Total this Invoice		\$860.00



FOX Strand
 414 South 17th Street, Suite 107
 Ames, IA 50010-8106
 (515) 233-0000

Invoice

Deanna McCusker
 City Administrator
 City of Washington
 City Hall
 215 East Washington Street
 Washington, IA 52353

August 10, 2022
 Project No: 7046.021
 Invoice No: 0186541

Professional Services: July 1, 2022 through July 31, 2022

Project	7046.021	Hwy 1 Development Concept Design		
Fee				
Total Fee		7,900.00		
Percent Complete		38.00	Total Earned	3,002.00
			Previous Fee Billing	1,422.00
			Current Fee Billing	1,580.00
			Total Fee	1,580.00
			Total this Invoice	\$1,580.00



FOX Strand
414 South 17th Street, Suite 107
Ames, IA 50010-8106
(515) 233-0000

Invoice

Deanna McCusker
 City Administrator
 City of Washington
 City Hall
 215 East Washington Street
 Washington, IA 52353

August 10, 2022
 Project No: 7046.001
 Invoice No: 0186539

Professional Services: July 1, 2022 through July 31, 2022

Project	7046.001	Washington Wastewater Treatment Plant - Consultation; IRE Pretreatment Agreement	
	Total Labor		116.00
		Total this Project	\$116.00

Project	7046.002	Washington Wastewater Treatment Plant - Linn Hollow Sanitary Sewer Connection	
		Total this Project	0.00
		Total this Invoice	\$116.00

TERMS: Payment is due within 30 days of the date on this invoice.

Please Remit Payment To: FOX Strand 414 South 17th Street, Suite 107 Ames, Iowa 50010-8106 515-233-0000

IMWCA
IOWA MUNICIPALITIES WORKERS' COMPENSATION ASSOCIATION
 500 SW 7TH STREET, SUITE 101
 DES MOINES, IA 50309-4506
 PHONE: 800-257-2708

INVOICE INV84204

DATE

8/1/2022

PAGE:

1

Mbr No: 0706 Member Name: Washington, City of

Washington, City of
 215 E Washington

Washington IA 52353

Please remit payment to: IMWCA, P.O. Box 8186, Des Moines, IA 50301

PURCHASE ORDER NO.	CUSTOMER ID	SALES ID	SHIPPING METHOD	PAYMENT TERMS	REQ'D SHIP DATE	MASTER NUMBER
	WASHI001	AG0075				
QUANTITY	ITEM NUMBER	DESCRIPTION	UOM	DISCOUNT	UNIT PRICE	EXTENDED PRICE
1.00	INSTALL2	Installment 2 - Work Comp Prem 22-23			6,909.00	\$6,909.00

This invoice is due on September 1, 2022.

A FINANCE CHARGE of 1.5% (APR 18%) will be added to balances over 30 days past the due date.

When you provide a check as payment, you authorize IMWCA either to use the information from your check to make a one-time electronic fund transfer from your account or to process the payment as a check transaction. For inquiries please call 515-244-7282.

Subtotal	\$6,909.00
Bond Credit	\$0.00
Misc	\$0.00
Total	\$6,909.00

Kevin D. Olson
Attorney-at-Law
1400 5th Street, P.O. Box 5127
Coralville, Iowa 52241

Phone (319) 351-2277 Fax: (319) 351-2279 e-mail: kevinolsonlaw@gmail.com

August 8, 2022

Sally Y. Hart, City Clerk
City of Washington, Iowa
215 E. Washington Street
Washington, Iowa 52353

INVOICE

For legal services rendered to the City of Washington, Iowa in June and July, 2022

TOTAL HOURS	20.5 hours (reg)
TOTAL MILES	462 miles
Hourly Rate	\$90/hour- Reg \$75/hour - Court
Mileage Rate	\$0.56 per mile
TOTAL INVOICE FOR JUNE AND JULY, 2022	\$2,103.72

City Administrator Report
August 16, 2022

- Kiwanis's Amer's meeting on Friday
- Nuisance meeting Thursday
- Holding Council one-on-one and department heads one-on-one
- City Administrator meeting on Friday
- Downtown community forum will be held Monday, August 22 at 2pm at the library
- Hotel study site visit was held Wednesday, August 10th. Very good information was collected. A report will be tentatively available for reviewing by the end of September.
- East Adams project: Working on storm and water main. Will start connections on 12th Monday. Following connections, they will remove and do subgrade prep.
- Sewer boring on the MSJ project will begin Monday, August 15th.
- NLW: All underground is complete. The grading and sub rock is done. Proof roll has passed. They will be working on preparing to pave next week with the hope to start paving the end of next week.
- Buchanan Street: All American will be here next week to work on sidewalk and driveway approaches
- Have attended ribbon cuttings/grand openings at Washington Hospice and Encore Express and will be attending one at Stout Seed and the open house at Bazooka
- Meeting to be held August 16th with Scooters coffee again
- Housing Initiative meeting next week
- We found out that we have been asked to submit a full application for the Home Rehabilitation Block Grant Pilot Program. The application is due October 31st and announcement will be made on or around December 7, 2022.

Home Rehabilitation Block Grant Pilot Program



PROGRAM OVERVIEW

The Home Rehabilitation Block Grant Pilot Program will offer eligible rural Iowa communities an opportunity to offer property owners in a targeted neighborhood financial assistance for eligible repair expenses to help preserve their homes and develop new affordable housing opportunities for Iowans. \$4 million is available through the pilot program.

Eligible activities include:

- Home repairs and weatherization costs for existing owner-occupied and rental properties
- Rehabilitation, renovation, maintenance, or costs to secure vacant or abandoned properties to reduce their negative impact
- Costs associated with acquiring and securing legal title of vacant or abandoned properties and other costs to position the property for current or future productive use
- Removal and remediation of environmental contaminants or hazards from vacant or abandoned properties, when conducted in compliance with applicable environmental laws or regulations
- Conversion of vacant or abandoned properties to affordable housing
- Inspection fees and other administrative costs incurred to ensure compliance with applicable environmental laws and regulations for demolition, greening, or other remediation activities

Funding must benefit households with incomes at or below 80% of the area median income as defined by [HUD](#) or households located within a [Qualified Census Tract](#).

New housing units developed under the program through the acquisition and rehabilitation of vacant or abandoned properties must be affordable to an income-qualified homebuyer or tenant household at initial occupancy and throughout a specified period of affordability.

Homeowners assisted under the program with home repair expenses must occupy the property as their principal residence.



PROGRAM POLICIES & GUIDELINES

ELIGIBLE APPLICANTS

- An Iowa municipal government of a rural community with a population under 30,000 (2020 Census), applying in partnership with eligible property owners in a targeted core neighborhood
- Individual property owners are ineligible to apply directly to the Iowa Finance Authority (IFA).

The Home Rehabilitation Block Grant Pilot Program is envisioned as a "hub and spoke" approach for rural cities that have reinvested in their downtowns to dedicate pilot program funding matched with significant local match resources and innovative public/private partnerships to revitalize a targeted residential neighborhood near the community's downtown. The program will provide eligible city applicants with an opportunity to transform that block off Main Street in the same way the community has already invested to revitalize its downtown.

All assisted units under the program must be subject to compliance monitoring by the Subrecipient during a period of affordability based upon the amount of Home Rehabilitation Block Grant Pilot Program assistance provided per housing unit. See charts below for specific affordability period requirements, which are the same as requirements under the HOME Program.

Home Rehabilitation Block Grant Pilot Program Assistance Per Unit or Buyer	Minimum Period of Affordability
Less than \$15,000	5 years
\$15,000 to \$40,000	10 years
More than \$40,000	15 years
New construction of rental housing	20 years

Applicants must provide a project timeline that guarantees program funds will be obligated by December 31, 2024. The funds for this award are provided by the State and Local Fiscal Recovery Fund (SLFRF), part of the American Rescue Plan. SLFRF requires that all costs be incurred during the period beginning the date of grant agreement execution and ending December 31, 2024. Therefore, all costs incurred prior to grant agreement execution and after December 31, 2024, are not eligible uses of these funds. The period of performance for SLFRF funds runs until December 31, 2026, which will provide recipients additional time during which they may expend funds for costs incurred (i.e., obligated) by December 31, 2024. Any award funds not obligated or expended within these timeframes must be returned to the State. Recipients of these funds will be held accountable to these funding timeframes.

AWARD AMOUNTS

Maximum grant award: \$1,000,000

HOW TO APPLY

Eligible applicants with an approved initial proposal are invited to apply using the [lowaGrants.gov](https://lowagrants.gov) application portal.

APPLICATION TIMELINE AND REVIEW

Applications must be submitted by Oct. 31, 2022.

REQUIRED APPLICATION ATTACHMENTS

Application materials requested in the application portal.

AWARD DECISIONS

Funding awards will be announced on or around December 7, 2022, with an initial grant performance period of two years from date of award approval. IFA reserves the right to pro-rate funding award amounts to all applicants meeting threshold requirements.

Subrecipients must obligate all program funding by no later than December 31, 2024. Extensions of the grant performance period will be considered on a case-by-case basis due to mitigating factors, including lack of contractor availability. In no case will expenditure of funds extend beyond December 31, 2026.



IOWA FINANCE AUTHORITY

1963 Bell Avenue, Suite 200
Des Moines, Iowa 50315

POST AWARD ACTIVITIES

Entities awarded funding through this program will enter into a grant agreement with IFA.

Program funds may be released on a reimbursement basis, as eligible project costs are incurred.

FEDERAL COMPLIANCE AND MONITORING

Program funds are available through the American Rescue Plan. The Subrecipient, as a non-federal entity carrying out a federal award on behalf of the State of Iowa, shall be considered a subrecipient as defined in the Uniform Guidance (2 CFR Part 200) and is subject to the requirements placed upon subrecipients by regulations including, but not limited to, the Uniform Guidance and 31 CFR 35.

All non-federal entities that spend more than \$750,000 in federal awards during the entity's fiscal year, including ARPA funds, must have a single or program-specific audit conducted for that year compliant with 2 CFR 200 Subpart F. This audit must cover the compliance of the entity with Federal statutes, regulations, and the terms and conditions of the federal award, as well as the fair presentation of the entity's financial statements, pursuant to the Uniform Guidance (2 CFR part 200).

Subrecipients must agree to retain all records relating to project cost, including supporting documents through December 31, 2032, and to make such records and documents available to IFA personnel upon request for audit.



Elm Grove & Woodlawn Cemeteries

Council Report for July 2022

In July, we mowed each cemetery twice. We also trimmed both cemeteries. I had 10 family requests for information this month. I marked out 8 foundations for installation. We trimmed trees in Elm Grove and Woodlawn. We have been watering trees that we planted last year. We also spent some time cleaning up the South end of the cemetery around the Buchanan Street construction. I sprayed for Japanese beetles in the young trees at both cemeteries, Wellness Park, Sunset Park, Central Park, City Hall, Madison Park, and the water treatment plant. We poured concrete in front of the Jones garage that was moved to cemetery, and removed a trip hazard and poured concrete between the office and garage. We removed several tree stumps at Woodlawn.

We have had 12 funerals at Elm Grove this month, for a total of 55 interments so far this year. We also had an infant disinterment from Elm Grove and was moved to another cemetery per the family's request. In August, we plan to continue with funeral services, updating cemetery records, continue mowing and trimming, trimming trees, and work on removing dead tree stumps. I will be taking vacation in August as well. Thank you.

Respectfully submitted,

Nicholas Duvall

Washington Fire Department
215 East Washington Street
Washington, Iowa 52353
(319) 653-2239 Phone
(319) 653-5273 Fax
www.washingtoniowa.gov



Brendan DeLong- Fire Chief
Bill Hartsock- 1st Asst Fire Chief
Jim Williams- 2nd Asst Fire Chief
Carrie Ornduff- Asst Chief of EMS

July 2022 Activity Report

Structure fires- 1
Weather related- 0
Mutual aid assists- 1
Hazardous Incidents- 1
Grass fires- 0
Investigate/good intent- 1
Rescue/accidents- 2
Medical- 65
July calls for service- 71

January 2022 – July 2022 calls for service

Fire calls - 97
Medical calls - 449
Total calls - 546

EMS Continues to be busy with 65 calls for service in July. We had a report of 1 structure fire in July. It was at 716 West 3rd Street. The cause was ruled to be electrical related. The upstairs of the house burnt up significantly. Damage was done to the entire house. Brighton, Ainsworth & Kalona fire departments assisted us. Other than that, July was a relatively quiet month in respect to fire calls. Medical calls continue to be around 65 a month.

We did not hold a monthly training in July, due to the county fair. Washington EMS & Fire assisted with numerous activities at the county fair. We were on event standby nearly every night.

I attended numerous department head meetings, county EMS & county fire meetings. I also attended a chiefs meeting with our dispatch center personnel to discuss paging operations & protocols for structure fire events. Full time staff continues to be busy responding to EMS & fire calls, fire inspections, rental inspections, and normal duties around the fire station. Year to date calls for service continue to be elevated.

Our July monthly fire meeting minutes are attached.

We are here and ready to respond.

Brendan DeLong
Fire Chief
Washington Fire Department

**WWTP report
August 16th , 2022
Council meeting**

- **After hour alarm and dog call outs –**
8-1-22 Dog call to Washington Country Club @ 6:50p.m. Dylan
8-6-22 Alarm to Lexington Lift station @ 4:00p.m. Dylan
- **Dept Head meetings –**July, 19th.Aug. 2nd,9th
- **Hydrogen Sulfide Gas-** We continue to have meetings and conference calls with IRE, NELCO,Fox eng., and City staff to resolve the issue. We did get four more hydrogen sulfide monitors for a total of seven. We have the monitors spread through the sewer system from IRE to the WWTP. We get readings from the monitors once a week, share and go over the information with everyone.
- **Parkside Lift Station-** The new lift station was installed and put in service on 8-10-22. Also installed at the same time was a ,Priming Lock Loop , that should help hold prime and prolong the life of the vacuum pumps. We also had a Vac Truck here at the same time to clean the wet well.
- **The Great Wastewater Treatment Tour Across Iowa-**On August 16th at 9:00a.m.we will be hosting a stop on a Wastewater Plant Tour put together by Craig Just of the University of Iowa and Grant Weaver of Grant Tech Solutions, and may be joined by IDNR officials, elected officials, and other Wastewater professionals. I will be going on Monday the 15th to visit Le Claire and North Liberty, then after Washington we will go to Mt. Pleasant. The purpose of the tour is for brainstorming ideas for optimizing nitrogen and phosphorus removal.
- **WWTP mowing-**mowing continues at the WWTP and lift stations with ongoing string trimming and weed control.
- **WWTP July 2022, Discharge Monitoring Report (DMR) –** Average daily flow **0.97 million gallons (mg)**, maximum daily flow **1.433 mg**, minimum daily flow **0.794 mg**. There were **zero (0)** violations of the WWTP's NPDES discharge permit. Total precipitation for July = **>1.37"** (recorded at the WWTP).

CBOD5 removal 85% required	result = 98.2 %
Influent CBOD5 monthly total =	1681 mg/L
Effluent CBOD5 monthly total =	29.57 mg/L

TSS removal 85% required	result = 99.38 %
Influent TSS monthly total =	3524 mg/L
Effluent TSS monthly total =	21.97 mg/L

The Plant is Required 85% removal of both CBOD aTSS.

**Jason Whisler
8/12/2022 8:00 A.M.**

MAINTENANCE & CONSTRUCTION DEPT. REPORT

7-23-22/8-5-22

STREETS: Personnel continued line painting. Vogel Traffic painted the center lines throughout the City limits. Personnel placed 27 ton of cold mix and rented a roller to flatten the seal coat streets, ditched an area on West 3rd St, in which LL Pelling came and all but finished this year's list of the 2022 contract. A pre-con meeting with Alliant and K&S for a gas line install along North 12th Ave, to find out that they will need 12th Ave closed the week of August 15th between East 11th St and East 7th St. Personnel cleaned up a tree and graded an alley west of B Ave north of West 3rd St.

WATER DISTRIBUTION: Personnel installed a farm hydrant inside the Wellness Park by the sand volleyball courts. Personnel shut off 14 water services for nonpayment. Personnel shut down the water main on numerous occasions for Cornerstone on the East Adams project for tie ins.

SEWER COLLECTION: Personnel N/A

STORM SEWER COLLECTION: Personnel N/A

MECHANIC/SHOP: Personnel serviced WWTP, PD 009 (rear hatch), PD TrailBlazer (repaired center console & replaced all the wipers), valve exerciser trailer, 301 (brakes), 601 (ready for auction), and treated fuel tanks.

OTHER: Personnel continued the yard waste collection. Personnel hauled numerous loads of rock and cold mix back to the shop. Responded to 68 One Call Locates.

*Please note that this report does not include every task M/C personnel performed, but shall be a highlight of our work performed as a department.



Washington Police Department

James Lester, Chief of Police

215 East Washington Street

Washington, Iowa 52353

Phone: 319-653-2256 Dispatch: 319-653-2107

Activity Report July 2022

Rhonda Hill
Administrative Assistant

Lyle Hansen
Lieutenant

Shamus Altenhofen
Lieutenant

Jason Chalupa
Sergeant

Benjamin Altenhofen
Sergeant

Brian VanWilligen
Investigator

Eric Kephart
K-9 Handler

Seth Adam
Police Officer

Aaron Kephart
Police Officer

Tanner Lavelly
Police Officer

Christopher Raymer
Police Officer

July ended with 426 calls for service, including 31 animal complaints (10 dogs at large and 11 animal welfare checks) and 28 fireworks complaints.

Officers were busy during fair week with both incidents and events. Officer Haworth, Lt. Altenhofen and Chief Lester participated in Washington County Emergency Management's Public Safety Day at the Fair.

Sgt. Chalupa recertified his Instructor status for firearms and rifle at the Iowa Law Enforcement Academy (ILEA) and Chief Lester assisted with two ILEA classes on domestic violence.

Officer Cardenas, Officer Brdecka and Lt. Altenhofen assisted the Fire Department with an Aircare visit to the Y-Daycare.

Mayor Rosien led a swearing in ceremony for Officer Brdecka on July 25th and she has been working through her Field Training with Sgt. Altenhofen and will begin the 16-week ILEA Basic Academy on August 29th.

Respectfully submitted,

Jim Lester
Chief of Police

Washington Police Department

215 East Washington Street
Washington, Iowa 52353
Phone: 319-653-2256 Dispatch: 319-653-2107

2022 Activity & Offense Report For the Month of: July

ACTIVITY	Previous Month	Current Month	Year – to – Date
Calls For Service	443	426	3029
Animal Calls	39	31	205
Citations / Warnings	14	12	232
Parking Tickets	1	0	50
Golf Cart/UTV Registrations	8	1	38
Vehicle Unlocks	28	28	218
Arrest Warrants Served	9	14	89
Search Warrants Served	1	0	35
Mental Health Crisis	8	14	102
Traffic Stops	28	29	282
Traffic Accidents	13	18	115
Arrests	25	21	222
Reportable Offenses	44	36	376
Assault	4	8	47
Burglary	2	4	18
Burglary to Motor Vehicle	2	1	15
Domestic Assault	1	2	13
No Contact Order Violation	1	1	15
Criminal Mischief/Vandalism	12	4	51
Drunkenness (Intoxication)	0	1	9
Driving Intoxicated (OWI)	1	1	10
Drug Offense	1	0	27
Drug Paraphernalia	0	0	12
Harassment/Intimidation	1	3	14
Sex Offense	0	0	4
Theft (Includes Shoplifting)	9	6	68
Trespass	1	0	3
Weapons Violation	0	0	2

This chart indicates a summary of the activity and offenses the Washington Police Department responded to during the reporting period. Some activity/offense types have been combined to simplify reporting. It should be noted an offense does not always result in an arrest. Calls for service do not always include return phone calls, assistance to other agencies and instances where officers are approached while on patrol for minor issues or requests for assistance.



SPECIAL EVENTS APPLICATION & HOLD HARMLESS AGREEMENT

PLEASE RETURN TO: Washington City Hall, 215 East Washington; ATTN: City Clerk
Contact info: Sally Hart, 319-653-6584 ext 131; sallyhart@washingtioniowa.gov

****Requires advance City Council approval- Council meets 1st & 3rd Tuesdays at 6 PM;
Completed applications are due the Thursday previous to the meeting****

1. APPLICANT INFORMATION

Name/Event: Hocus Pocus in the Park

Coordinator: Alisha Davis

Contact Number: 319-653-3272

Email Address: alisha@washingtioniowa.org

2. EVENT INFORMATION

Event Description: Celebrate Halloween & all things Fall in Central Park on Saturday October 8th.
The Washington Chamber of Commerce, Relay for Life, & Main Street Washington are partnering
on this event to provide family friendly events including costume contest, candy giveaway, Movie
in the park, & more

Days/Dates of Event: Saturday October 8th, 2022

Time(s) of Event: (Include Set Up/Tear Down Time) 4-11 pm

Event Location: Central Park & Marion Avenue

Will event require an alcohol license or require modification of an existing license? Yes No

3. REQUEST INFORMATION (Check All Applicable Items)

If you are requesting the closing of a city street, a lane must be maintained for emergency vehicles at all times.

Temporarily close a street for a special event (specify street, times, and indicate on map:)

Description: Closure of Marion Avenue for Food Trucks & Bags Tournament provided
by Relay for Life. Parking on the Northside (against park) will be utilized for Hayrack
rides. Pony rides will be on the East side of the square. Times are indicated on the map

Method of Notification for businesses/downtown residents (if applicable):

Will need barricades & cones for the closures.

Other Requests

_____ Temporarily park in a "No Parking" area
location : _____

_____ Use of City Park (specify park :
Electrical Needs: _____

_____ Walk/Run (attach map of route and indicate
streets to be closed)

_____ Fireworks (specify location :)

_____ Use of gators/UTV/ATV on City streets

_____ Parade (attach map of route and indicate
streets to be closed)

_____ Tent(s) to be used – over 400 sq ft or canopies
over 1,000 sq ft

_____ Other (please specify :)

4. ITEMS REQUESTED FROM THE CITY OF WASHINGTON

Street barricades

_____ Emergency "No Parking" Signs

Traffic cones

_____ Picnic Tables

Yield signs for crosswalks

Garbage/Recycling Barrels

_____ Street Sweeping following (parades)

_____ Other (please specify :)

5. SOUND SYSTEMS Please indicate if the following will be used (verify availability with Parks Dept):

Amplified Sound/Speaker System

Public Address System

_____ Recorded/Live Music

_____ If so: BMI/ASCAP License obtained?

6. SANITATION Applicant is responsible for the clean-up of the event area immediately following the event, including trash removal from the site unless special arrangements are made (event trash may be hauled to Parks Shop dumpster at Sunset Park).

Will additional restrooms be brought to the site? _____ Yes No If yes, how many? _____
(General guideline of 1 restroom/100 people)

Will handwashing/hand sanitizer stations be provided? _____ Yes No If yes, how many?)

Contact Person: _____

Phone: _____

7. INSURANCE

For **events** requiring an **alcohol license**, the minimum amount of coverage in the general liability insurance policy shall be \$2,000,000 general aggregate, \$1,000,000 personal injury and \$1,000,000 each occurrence. The minimum limits for the liquor liability policy shall be \$500,000. For all other **events held on public property**, the minimum amount of coverage for the general liability insurance policy will be \$500,000. Proof of proper insurance coverage must be submitted prior to City Council consideration of the application. City Council may require certificate of insurance with City listed as "additional insured" if deemed necessary.

Certificate of Insurance provided and accepted _____ Certificate of Insurance not required

8. AGREEMENT

In consideration of the City of Washington, Iowa, granting permission for the activity described above, the undersigned indemnifies and holds harmless the City of Washington, Iowa, its employees, representatives and agents against all claims, liabilities, losses or damage for personal injury and/or property damage or any other damage whatsoever on account of the activity described above and/or deviation from normal City regulations in the area. The undersigned further agrees to indemnify and hold harmless the City of Washington, Iowa, its employees, representatives and agents against any loss, injury, death or damage to person or property and against all claims, demands, fines, suits, actions, proceedings, orders, decrees and judgments of any kind or nature and from and against any and all costs and expenses including reasonable attorney fees which at any time may be suffered or sustained by the undersigned or by any person who may, at any time, be using or occupying or visiting the premises of the undersigned or the above-referenced public property or be in, on or about the same, when such loss, injury, death or damage shall be caused by or in any way result from or rising out of any act, omission or negligence of any of the undersigned or any occupant, visitor, or user of any portion of the premises or shall result from or be caused by any other matters or things whether the same kind, as, or of a different kind that the matters or things above set forth. The undersigned hereby waives all claims against the city for damages to the building or improvements that are now adjacent to said public property or hereafter built or placed on the premises adjacent to said property or in, on or about the premises and for injuries to persons or property in or about the premises, from any cause arising at any time during the activity described above. The undersigned further agrees to comply with all the codes, rules, regulations, terms and conditions established by the City of Washington, Iowa.

THE UNDERSIGNED HAS READ AND FULLY UNDERSTANDS THIS DOCUMENT, INCLUDING THE FACT IT IS RELEASING AND WAIVING CERTAIN POTENTIAL RIGHTS, AND VOLUNTARILY AND FREELY AGREES TO THE TERMS AND CONDITIONS AS SET FORTH HEREIN.

Applicant/Sponsor Signature

Date

DEPARTMENT APPROVALS

<u>Indicate Date Contacted</u>	The applicant is responsible for coordinating with all applicable departments in advance of City Council consideration.			
<u>8/11/22</u>	City Clerk (Liquor Licenses)	Sally Y. Hart	319-653-6584 ext 131	sallyhart@washingtioniowa.gov
	Comments/Restrictions:			
<u>8/11/22</u>	Police Chief	Jim Lester	319-458-0264	jlester@washingtioniowa.gov
	Comments/Restrictions:			
<u>8/11/22</u>	Fire Chief	Brendan DeLong	319-461-3796	bdelong@washingtioniowa.gov
	Comments/Restrictions:			
<u>8/11/22</u>	Streets	JJ Bell	319-653-1538	jjbell@washingtioniowa.gov
	Comments/Restrictions:			
<u>8/11/22</u>	Parks	Nick Pacha	319-321-4886	npacha@washingtioniowa.gov
	Comments/Restrictions:			
	County Environmental Health (if serving food): Jason Taylor; 319-461-2876; jtaylor@co.washington.ia.us			
	Comments/Restrictions:			

CITY COUNCIL APPROVAL

City Clerk Signature

Date of Action

Approved: _____ Denied: _____

CONDITIONS IMPOSED: _____

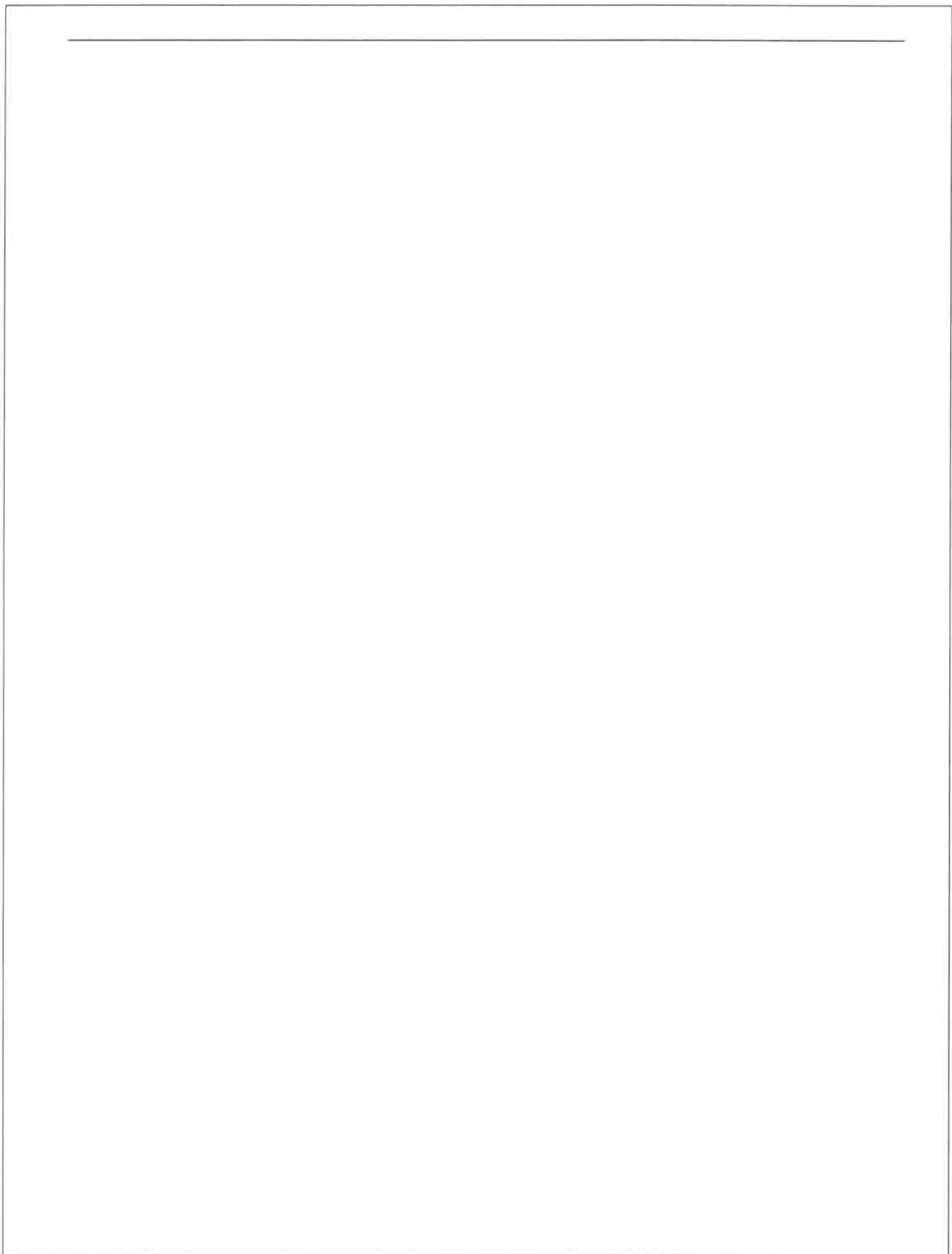

Downtown Map (If Area Outside Downtown, Please Attach a Map):

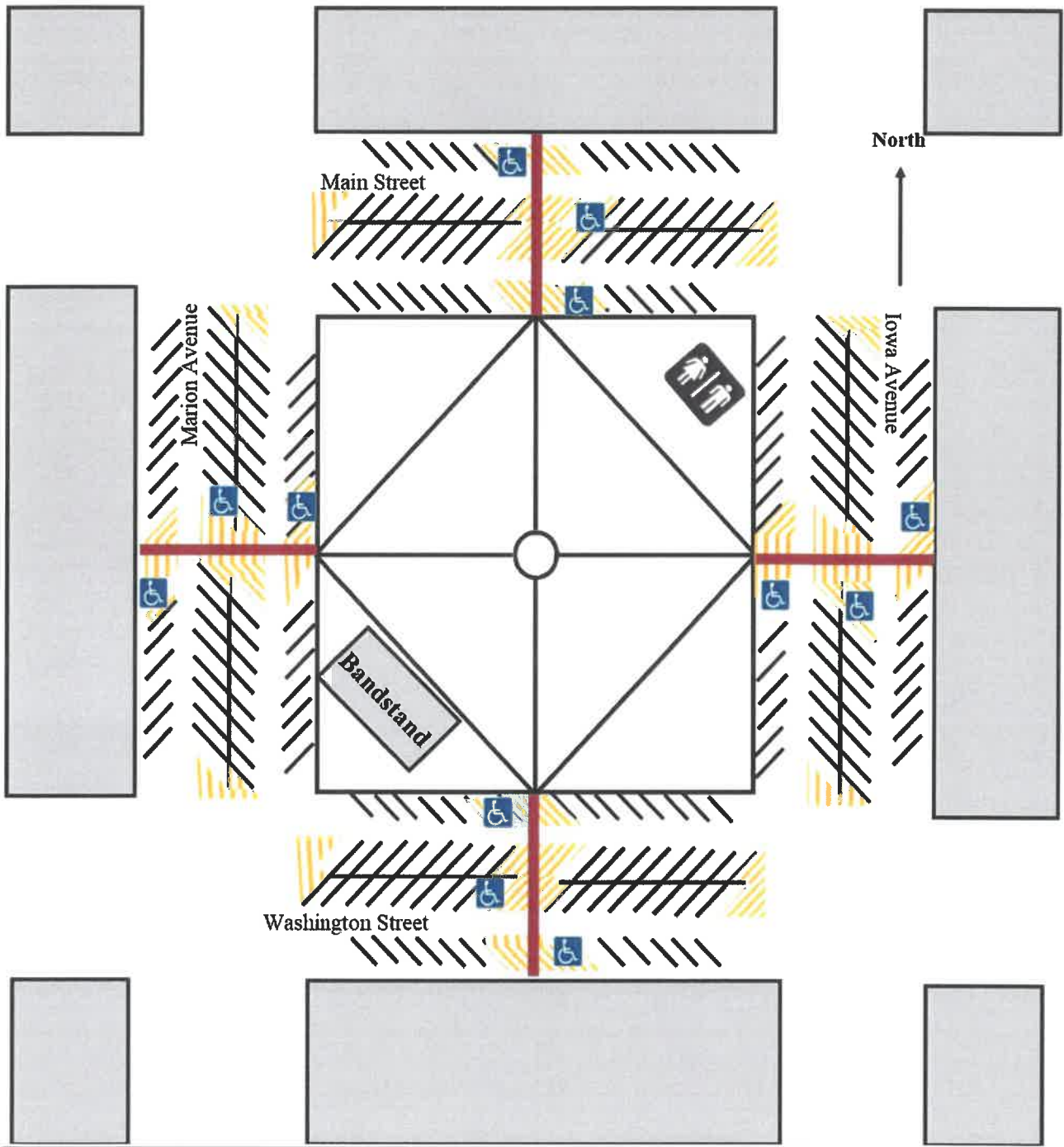

Hocus Pocus in the Park Map

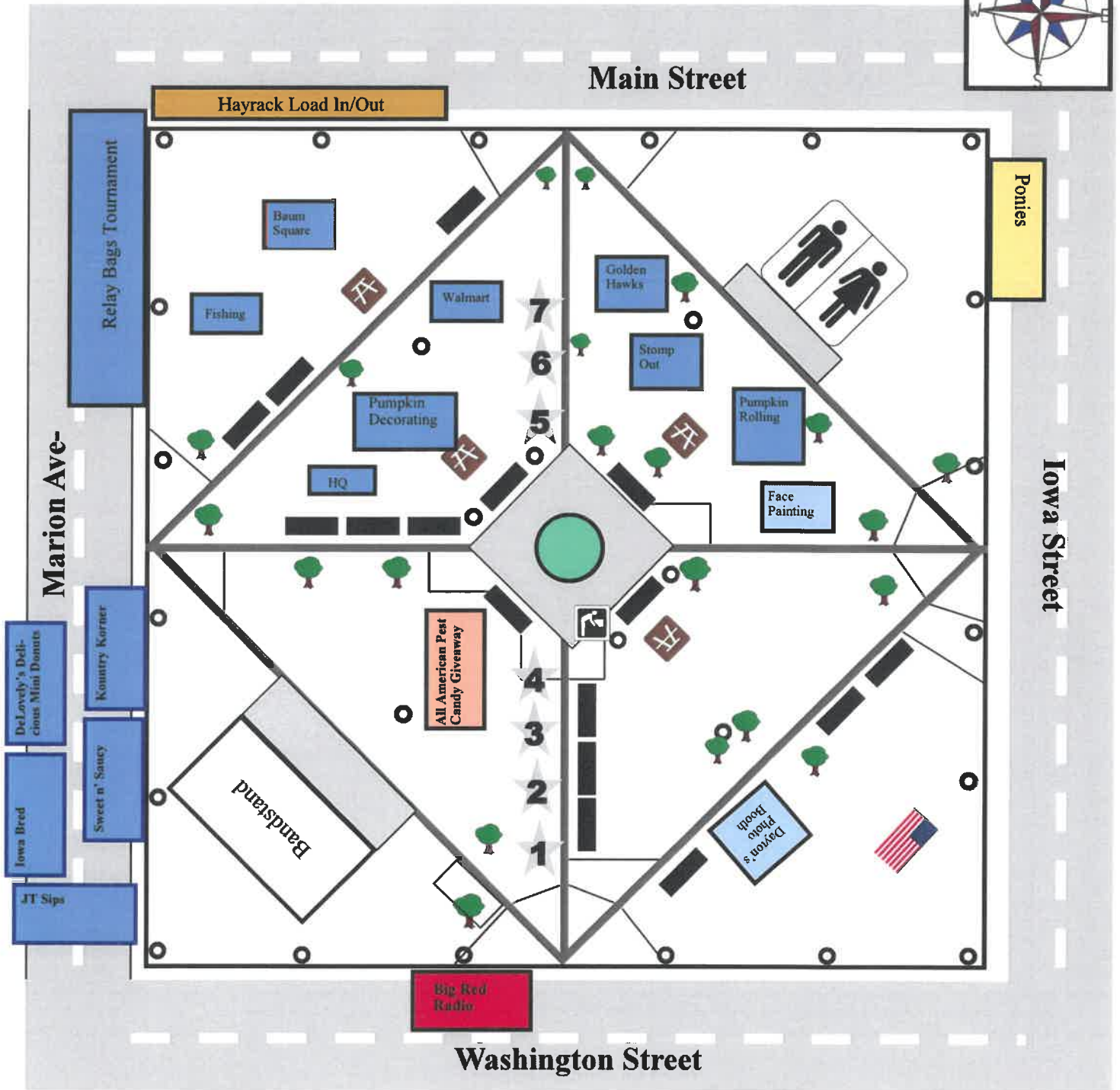

SCHEDULE

- 1-3 p.m.: Survivor Recognition
- 3:00 p.m.: Dessert Auction
- 3:00 p.m. KCII Big Red Radio
- 4:30-7:00 p.m.: Dayton Schluetter Pumpkin Polaroids, Relay games, Candy Bag Giveaway, Pony Rides, Hayrack Rides, adult bags tournament
- 5:00-6:00 p.m. Costume Parade
- 6:00-7:00 p.m. Magic Show on Stage
- 7:30 p.m. Movie Begins

VOLUNTEERS

- Pony Rides- 4-7pm: Windy Acres & Margaret Ziglowsky
- Hayrack Rides- 4-7:30pm: Susan, Ila & Carol
- Candy Sponsors-All American Pest Control
- Bandstand: Alisha & Sarah
- Clean-Up Crew: Genie & WCDC

Point of Contact: Alisha Davis 319-750-1546

- 1 Vettes Culligan
- 2 Nurturing Families
- 3 Gray Canine
- 4 Old & New/IA Gym Nest
- 5 Hills Bank
- 6
- 7

Downtown Map (If Area Outside Downtown, Please Attach a Map):

Hocus Pocus in the Park

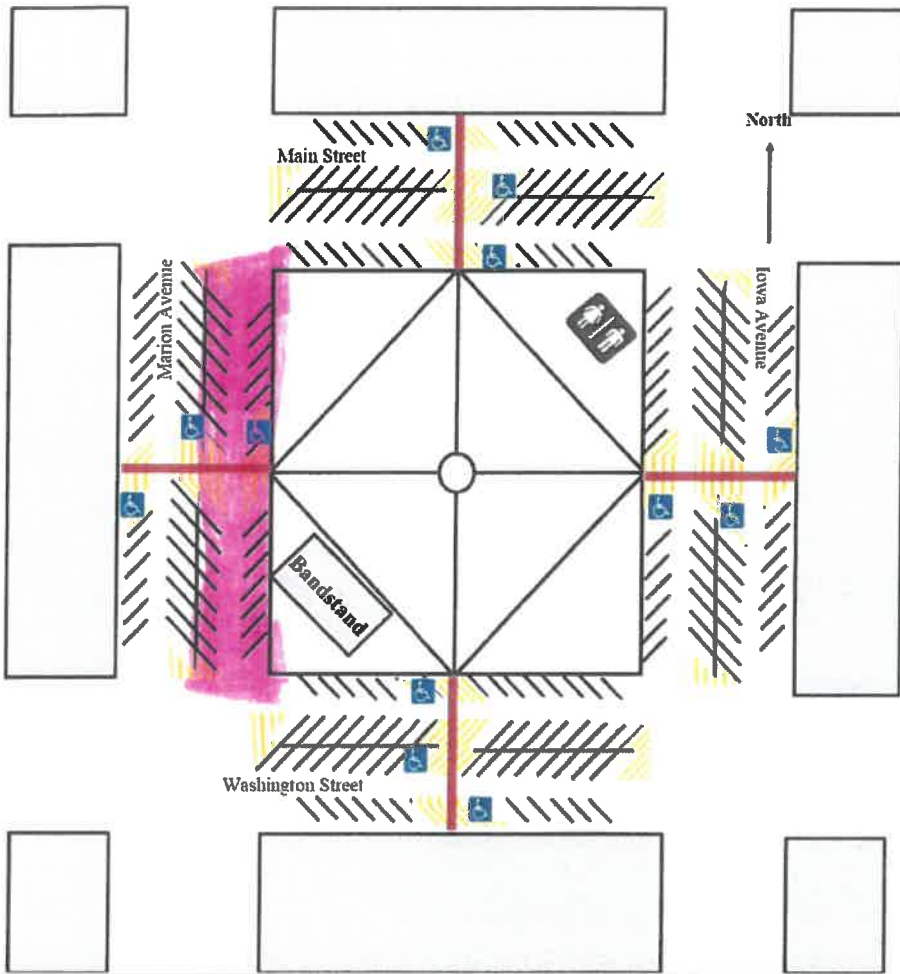



SPECIAL EVENTS APPLICATION & HOLD HARMLESS AGREEMENT

PLEASE RETURN TO: Washington City Hall, 215 East Washington; ATTN: City Clerk
Contact info: Sally Hart, 319-653-6584 ext 131; sallyhart@washingtioniowa.gov

****Requires advance City Council approval- Council meets 1st & 3rd Tuesdays at 6 PM;
Completed applications are due the Thursday previous to the meeting****

1. APPLICANT INFORMATION

Name/Event: SNOW: Lighting Ceremony, Hayrack Rides, & Holiday Parade

Coordinator: Main Street Washington

Contact Number: 319-653-3918

Email Address: mainstreet@washingtioniowa.org

2. EVENT INFORMATION

Event Description: Our annual kick-off to the Holiday with our Lighting Ceremony, the Live Radio Play, & the Lighted Holiday parade around the square.

Radio Play (@ Library) 5-6 pm, Lighting Ceremony 6-6:30, Hayrack (tentative 6-8 pm) & Parade 6:30-7 pm.)

Days/Dates of Event: Saturday November 26, 2022

Time(s) of Event: (Include Set Up/Tear Down Time) 4:30-9 pm

Event Location: Downtown, focused on Bandstand.

Will event require an alcohol license or require modification of an existing license? Yes No

3. REQUEST INFORMATION (Check All Applicable Items)

If you are requesting the closing of a city street, a lane must be maintained for emergency vehicles at all times.

Temporarily close a street for a special event (specify street, times, and indicate on map:)

Description: Close Washington St. in front of Library for the Radio Play so that spectators may views through the window starting at 4:30, followed by the entire square for the

Parade starting about 5:30 closing just the outside driving lane. Also request use of the park for the Lights of Love Memorial Trees. Noted on Map.

Method of Notification for businesses/downtown residents (if applicable):

Media Release, social media, & postcards to mailboxes. Signs will be placed in cones around downtown stating no parking after 4:30 for the parade.

Other Requests

Temporarily park in a "No Parking" area
location : _____

Use of City Park (specify park : _____
Electrical Needs: _____

Walk/Run (attach map of route and indicate
streets to be closed)

Fireworks (specify location :)

Use of gators/UTV/ATV on City streets

Parade (attach map of route and indicate
streets to be closed)

Tent(s) to be used – over 400 sq ft or canopies
over 1,000 sq ft

Other (please specify :)

4. ITEMS REQUESTED FROM THE CITY OF WASHINGTON

Street barricades

Emergency "No Parking" Signs

Traffic cones

Picnic Tables

Yield signs for crosswalks

Garbage/Recycling Barrels

Street Sweeping following (parades)

Other (please specify :)

5. SOUND SYSTEMS Please indicate if the following will be used (verify availability with Parks Dept):

Amplified Sound/Speaker System

Public Address System

Recorded/Live Music

If so: BMI/ASCAP License obtained?

6. SANITATION Applicant is responsible for the clean-up of the event area immediately following the event, including trash removal from the site unless special arrangements are made (event trash may be hauled to Parks Shop dumpster at Sunset Park).

Will additional restrooms be brought to the site? Yes No If yes, how many? _____
(General guideline of 1 restroom/100 people)

Will handwashing/hand sanitizer stations be provided? Yes No If yes, how many?)

Contact Person: TBD

Phone: _____

7. INSURANCE

For events requiring an alcohol license, the minimum amount of coverage in the general liability insurance policy shall be \$2,000,000 general aggregate, \$1,000,000 personal injury and \$1,000,000 each occurrence. The minimum limits for the liquor liability policy shall be \$500,000. For all other events held on public property, the minimum amount of coverage for the general liability insurance policy will be \$500,000. Proof of proper insurance coverage must be submitted prior to City Council consideration of the application. City Council may require certificate of insurance with City listed as "additional insured" if deemed necessary.

Certificate of Insurance provided and accepted Certificate of Insurance not required

8. AGREEMENT

In consideration of the City of Washington, Iowa, granting permission for the activity described above, the undersigned indemnifies and holds harmless the City of Washington, Iowa, its employees, representatives and agents against all claims, liabilities, losses or damage for personal injury and/or property damage or any other damage whatsoever on account of the activity described above and/or deviation from normal City regulations in the area. The undersigned further agrees to indemnify and hold harmless the City of Washington, Iowa, its employees, representatives and agents against any loss, injury, death or damage to person or property and against all claims, demands, fines, suits, actions, proceedings, orders, decrees and judgments of any kind or nature and from and against any and all costs and expenses including reasonable attorney fees which at any time may be suffered or sustained by the undersigned or by any person who may, at any time, be using or occupying or visiting the premises of the undersigned or the above-referenced public property or be in, on or about the same, when such loss, injury, death or damage shall be caused by or in any way result from or rising out of any act, omission or negligence of any of the undersigned or any occupant, visitor, or user of any portion of the premises or shall result from or be caused by any other matters or things whether the same kind, as, or of a different kind that the matters or things above set forth. The undersigned hereby waives all claims against the city for damages to the building or improvements that are now adjacent to said public property or hereafter built or placed on the premises adjacent to said property or in, on or about the premises and for injuries to persons or property in or about the premises, from any cause arising at any time during the activity described above. The undersigned further agrees to comply with all the codes, rules, regulations, terms and conditions established by the City of Washington, Iowa.

THE UNDERSIGNED HAS READ AND FULLY UNDERSTANDS THIS DOCUMENT, INCLUDING THE FACT IT IS RELEASING AND WAIVING CERTAIN POTENTIAL RIGHTS, AND VOLUNTARILY AND FREELY AGREES TO THE TERMS AND CONDITIONS AS SET FORTH HEREIN.

Sarah Grunewaldt

Applicant/Sponsor Signature

8/11/22

Date

DEPARTMENT APPROVALS

<u>Indicate Date Contacted</u>	The applicant is responsible for coordinating with all applicable departments in advance of City Council consideration.			
<u>8/11/22</u>	City Clerk (Liquor Licenses)	Sally Y. Hart	319-653-6584 ext 131	sallyhart@washingtioniowa.gov Comments/Restrictions:
<u>8/11/22</u>	Police Chief	Jim Lester	319-458-0264	jlester@washingtioniowa.gov Comments/Restrictions:
<u>8/11/22</u>	Fire Chief	Brendan DeLong	319-461-3796	bdelong@washingtioniowa.gov Comments/Restrictions:
<u>8/11/22</u>	Streets	JJ Bell	319-653-1538	jjbell@washingtioniowa.gov Comments/Restrictions:
<u>8/11/22</u>	Parks	Nick Pacha	319-321-4886	npacha@washingtioniowa.gov Comments/Restrictions:
	County Environmental Health (if serving food): Jason Taylor; 319-461-2876; jtaylor@co.washington.ia.us Comments/Restrictions:			

CITY COUNCIL APPROVAL

City Clerk Signature

Date of Action

Approved: _____ Denied: _____

CONDITIONS IMPOSED: _____

SNOW Parade & Events Layout 2022

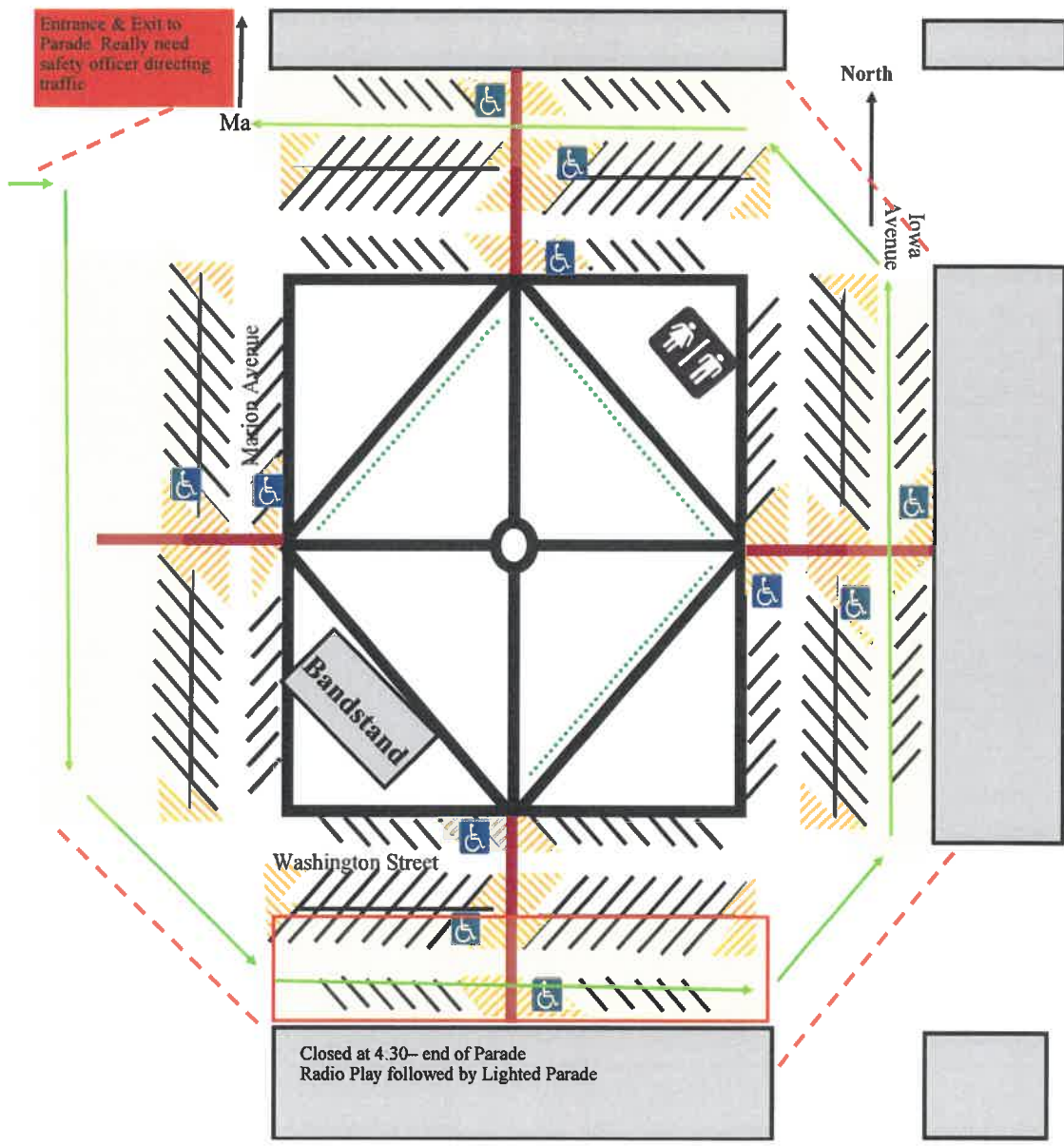

Key:

--- Barricades

▨ Parking closure for Parade

→ Parade Route

⋯ Lights of Love Memory trees

Entrance & Exit to Parade Really need safety officer directing traffic

Closed at 4.30- end of Parade
Radio Play followed by Lighted Parade

Bandstand



Ma

Macon Avenue

Washington Street

North

Iowa Avenue

-  Parking Lots
-  WPD Squad Cars
-  Type A Barricades





Case Report

07/01/2022 - 08/09/2022

Case Date	Main Status	Actions Taken	Method of Warning	Parcel Address	Description
-----------	-------------	---------------	-------------------	----------------	-------------

Group: Closed

8/5/2022	Closed		Hanger	514 N MARION AVE	trailers on grass
8/5/2022	Closed	emailed landlord	Email	116 N 2ND AVE	furniture at curb
8/3/2022	Closed		Text Message	608 E 2ND ST	high grass
8/3/2022	Closed	called metal scrapper	Verbal Warning	717 E 2ND ST	washer at curb
8/2/2022	Closed	left message	Phone Call	421 E JEFFERSON ST	high grass
8/1/2022	Closed	called Terry Reschley	Phone Call	N 12TH AVE	weeds
7/27/2022	Closed		Phone Call	814 E VAN BUREN ST	weeds
7/25/2022	Closed		Hanger	1030 N IOWA AVE	weeds around garage and fire hydrant
7/22/2022	Closed	took pictures	Letter	1004 E WASHINGTON ST	weeds & overgrowth on sidewalk
7/21/2022	Closed	called realtor	Phone Call	502 W 3RD ST	weeds in ROW
7/21/2022	Closed	called landlord	Phone Call	311 N C AVE	junk at curb
7/21/2022	Closed	left message	Phone Call	534 S MARION AVE	high grass
7/21/2022	Closed	took pictures	Letter	316 S B AVE	junk vehicle, trash, weeds
7/21/2022	Closed		Hanger	303 W MADISON ST	high grass
7/20/2022	Closed		Hanger	902 E WASHINGTON ST	high grass

7/19/2022	Closed		Phone Call	502 W MADISON ST	weeds in alley
7/19/2022	Closed		Phone Call	104 W MAIN ST	weeds in alley
7/19/2022	Closed		Email	403 E MADISON ST	weeds in ROW
7/19/2022	Closed		Phone Call	1114 E WASHINGTON ST	grass needs cut
7/19/2022	Closed		Hanger	903 E 3RD ST	grass needs mowed
7/19/2022	Closed		Hanger	914 E 3RD ST	grass needs mowed
7/15/2022	Closed	took picture	Letter	202 S IOWA AVE	weeds in alley
7/12/2022	Closed		Phone Call	114 N Iowa	weeds along fence and sidewalk
7/12/2022	Closed	sent email 08/01/2022	Hanger	615 E TYLER ST	high grass
7/11/2022	Closed		Email	632 E 3rd St	high grass
7/11/2022	Closed		Email	741 E 2ND ST	not mowing in ROW
7/11/2022	Closed		Email	210 N MARION AVE	high weeds in alley and sidewalk
7/11/2022	Closed	called landlord 7/29 since renters are moving out	Hanger	409 S IOWA AVE	tree branches need trimmed on sidewalk
7/8/2022	Closed	she had stickers to put on for Monday pick up	Verbal Warning	420 W 7TH ST	furniture at curb
7/7/2022	Closed	emailed corporate office took picture of yard	Email	1730 E WASHINGTON ST	blue towels blowing into neighbors yard
7/7/2022	Closed	called metal scrapper	Phone Call	907 S B AVE	appliance at curb
7/6/2022	Closed		Hanger	709 S 3RD AVE	furniture at curb

7/5/2022	Closed	called again on 7/12	Phone Call	123 E 2ND ST	weeds south side of building
7/5/2022	Closed	called landlord	Phone Call	219 W JEFFERSON ST	furniture at curb
7/5/2022	Closed		Phone Call	1409 E WASHINGTON ST	weeds in ROW
7/5/2022	Closed	took picture	Letter	906 W MAIN ST	dead tree
7/1/2022	Closed	took picture	Letter	404 E WASHINGTON ST	dead tree
7/1/2022	Closed		Hanger	702 N 4TH AVE	furniture t curb

Group Total: 38

Group: Open

8/9/2022	Open		Email	803 S 3RD AVE	boat & truck on grass
8/9/2022	Open		Hanger	907 S B AVE	mattress at curb
8/9/2022	Open		Hanger	726 E WASHINGTON ST	furniture at curb
8/9/2022	Open		Hanger	331 N 4TH AVE	weeds
8/9/2022	Open		Hanger	514 S MARION AVE	flowers growing in public sidewalk
8/9/2022	Open		Email	622 S 2ND AVE	trailer on grass
8/9/2022	Open		Hanger	806 S 2ND AVE	vehicle on grass
8/9/2022	Open		Email	515 S 4TH AVE	high weeds
8/8/2022	Open	took pictures		201 S MARION AVE	Bricks falling
8/4/2022	Open	took pictures	Letter	114 E 7TH ST	junk vehicles and weeds
8/3/2022	Open	took pictures	Letter	406 E MAIN ST	high weeds in backyard
8/3/2022	Open	took pictures	Letter	609 E 2ND ST	dead tree
8/3/2022	Open	took pictures	Letter	614 E 2ND ST	dead tree

8/2/2022	Open	took pictures	Letter	401 E JEFFERSON ST	dead trees
8/2/2022	Open		Hanger	514 S 9TH AVE	high weeds
7/29/2022	Open		Email	733 E 2ND ST	dead tree
7/22/2022	Open		Letter	918 E 3RD ST	dead tree
7/20/2022	Open		Letter	702 E 2ND ST	dead tree
7/20/2022	Open	took pictures	Letter	602 E WASHINGTON ST	junk in yard
7/18/2022	Open		Email	316 E MAIN ST	bushes in alley need trimmed
7/15/2022	Open	took pictures	Letter	109 E WASHINGTON ST	weeds in alley
7/15/2022	Open	took pictures	Letter	200 S IOWA AVE	weeds in alley
7/15/2022	Open	took pictures	Letter	206 S IOWA AVE	weeds in alley
7/15/2022	Open	took pictures	Letter	208 S IOWA AVE	clean up alley
7/15/2022	Open	took pictures	Letter	210 S IOWA AVE	clean up alley
7/8/2022	Open		Hanger	105 W 15TH ST	weeds around garage and deck
7/7/2022	Open	took pictures	Letter	806 S 2ND AVE	2 dead trees
7/7/2022	Open	took picture	Letter	809 S MARION AVE	dead tree
7/6/2022	Open	took pictures	Letter	525 W 3RD ST	junk vehicle
7/1/2022	Open	took picture	Letter	1100 N 6TH AVE	dead tree
7/1/2022	Open	took pictures	Letter	1025 N 4TH AVE	2 dead trees front yard

Group Total: 31

--	--	--	--	--	--

Total Records: 69

8/9/2022



SPECIAL EVENTS APPLICATION & HOLD HARMLESS AGREEMENT

PLEASE RETURN TO: Washington City Hall, 215 East Washington; ATTN: City Clerk
Contact info: Sally Hart, 319-653-6584 ext 131; sallyhart@washingtioniowa.gov

****Requires advance City Council approval- Council meets 1st & 3rd Tuesdays at 6 PM;
Completed applications are due the Thursday previous to the meeting****

1. APPLICANT INFORMATION

Name/Event: Mama llamas Barn Grand opening

Coordinator: Karisa Mellinger

Contact Number: 701-334-7094

Email Address: hello@mumallamasbarn.com

2. EVENT INFORMATION

Event Description: Grand opening of Mama llamas barn, photography spot w/ Real llamas, boutique shopping & ribbon cutting

Days/Dates of Event: September 7th 4-8pm

Time(s) of Event: (Include Set Up/Tear Down Time) September 3-9 ^{they are going to be here 2 hours @ most.}

Event Location: 124 W. Main St.

Will event require an alcohol license or require modification of an existing license? Yes No

3. REQUEST INFORMATION (Check All Applicable Items)

If you are requesting the closing of a city street, a lane must be maintained for emergency vehicles at all times.

Temporarily close a street for a special event (specify street, times, and indicate on map:)

Description: Close first row of parking ~~next~~ on the west side of the building.

Method of Notification for businesses/downtown residents (if applicable):

Other Requests

_____ Temporarily park in a "No Parking" area location : _____

_____ Use of City Park (specify park : _____
Electrical Needs: _____

_____ Walk/Run (attach map of route and indicate streets to be closed)

_____ Fireworks (specify location :)

_____ Use of gators/UTV/ATV on City streets

_____ Parade (attach map of route and indicate streets to be closed)

_____ Tent(s) to be used – over 400 sq ft or canopies over 1,000 sq ft

_____ Other (please specify :)

4. **ITEMS REQUESTED FROM THE CITY OF WASHINGTON**

_____ Street barricades

_____ Emergency "No Parking" Signs

Traffic cones

_____ Picnic Tables

_____ Yield signs for crosswalks

_____ Garbage/Recycling Barrels

_____ Street Sweeping following (parades)

_____ Other (please specify :)

5. **SOUND SYSTEMS** Please indicate if the following will be used (verify availability with Parks Dept):

_____ Amplified Sound/Speaker System

_____ Public Address System

_____ Recorded/Live Music

_____ If so: BMI/ASCAP License obtained?

6. **SANITATION** Applicant is responsible for the clean-up of the event area immediately following the event, including trash removal from the site unless special arrangements are made (event trash may be hauled to Parks Shop dumpster at Sunset Park).

Will additional restrooms be brought to the site? _____ Yes _____ No If yes, how many? _____
(General guideline of 1 restroom/100 people)

Will handwashing/hand sanitizer stations be provided? _____ Yes _____ No If yes, how many?)

Contact Person: _____

Phone: _____

7. **INSURANCE**

For **events** requiring an **alcohol license**, the minimum amount of coverage in the general liability insurance policy shall be \$2,000,000 general aggregate, \$1,000,000 personal injury and \$1,000,000 each occurrence. The minimum limits for the liquor liability policy shall be \$500,000. For all other **events** held on **public property**, the minimum amount of coverage for the general liability insurance policy will be \$500,000. Proof of proper insurance coverage must be submitted prior to City Council consideration of the application. City Council may require certificate of insurance with City listed as "additional insured" if deemed necessary.

Certificate of Insurance provided and accepted _____ Certificate of Insurance not required

8. AGREEMENT

In consideration of the City of Washington, Iowa, granting permission for the activity described above, the undersigned indemnifies and holds harmless the City of Washington, Iowa, its employees, representatives and agents against all claims, liabilities, losses or damage for personal injury and/or property damage or any other damage whatsoever on account of the activity described above and/or deviation from normal City regulations in the area. The undersigned further agrees to indemnify and hold harmless the City of Washington, Iowa, its employees, representatives and agents against any loss, injury, death or damage to person or property and against all claims, demands, fines, suits, actions, proceedings, orders, decrees and judgments of any kind or nature and from and against any and all costs and expenses including reasonable attorney fees which at any time may be suffered or sustained by the undersigned or by any person who may, at any time, be using or occupying or visiting the premises of the undersigned or the above-referenced public property or be in, on or about the same, when such loss, injury, death or damage shall be caused by or in any way result from or rising out of any act, omission or negligence of any of the undersigned or any occupant, visitor, or user of any portion of the premises or shall result from or be caused by any other matters or things whether the same kind, as, or of a different kind that the matters or things above set forth. The undersigned hereby waives all claims against the city for damages to the building or improvements that are now adjacent to said public property or hereafter built or placed on the premises adjacent to said property or in, on or about the premises and for injuries to persons or property in or about the premises, from any cause arising at any time during the activity described above. The undersigned further agrees to comply with all the codes, rules, regulations, terms and conditions established by the City of Washington, Iowa.

THE UNDERSIGNED HAS READ AND FULLY UNDERSTANDS THIS DOCUMENT, INCLUDING THE FACT IT IS RELEASING AND WAIVING CERTAIN POTENTIAL RIGHTS, AND VOLUNTARILY AND FREELY AGREES TO THE TERMS AND CONDITIONS AS SET FORTH HEREIN.

Karisa Mellinger
Applicant/Sponsor Signature

8/15/22
Date

DEPARTMENT APPROVALS

Indicate Date Contacted	The applicant is responsible for coordinating with all applicable departments in advance of City Council consideration.			
	City Clerk (Liquor Licenses)	Sally Y. Hart <i>nm</i>	319-653-6584 ext 131	sallyhart@washingtioniowa.gov
	Comments/Restrictions:			
<u>8/15</u>	Police Chief	Jim Lester	319-458-0264	jlester@washingtioniowa.gov
	Comments/Restrictions: <i>OK with it!!</i>			
<u>8/15</u> <i>left msg</i>	Fire Chief	Brendan DeLong	319-461-3796	bdelong@washingtioniowa.gov
	Comments/Restrictions:			
<u>8/15</u> <i>know of</i>	Streets	JJ Bell <i>cones</i>	319-653-1538	jjbell@washingtioniowa.gov
	Comments/Restrictions: <i>will bring up cones</i>			
	Parks	Nick Pacha	319-321-4886	npacha@washingtioniowa.gov
	Comments/Restrictions:			
	County Environmental Health (if serving food): <i>no</i>			
	Jason Taylor; 319-461-2876; jtaylor@co.washington.ia.us			
	Comments/Restrictions:			

CITY COUNCIL APPROVAL

City Clerk Signature

Date of Action

Approved: _____ Denied: _____

CONDITIONS IMPOSED: _____

Downtown Map (If Area Outside Downtown, Please Attach a Map):

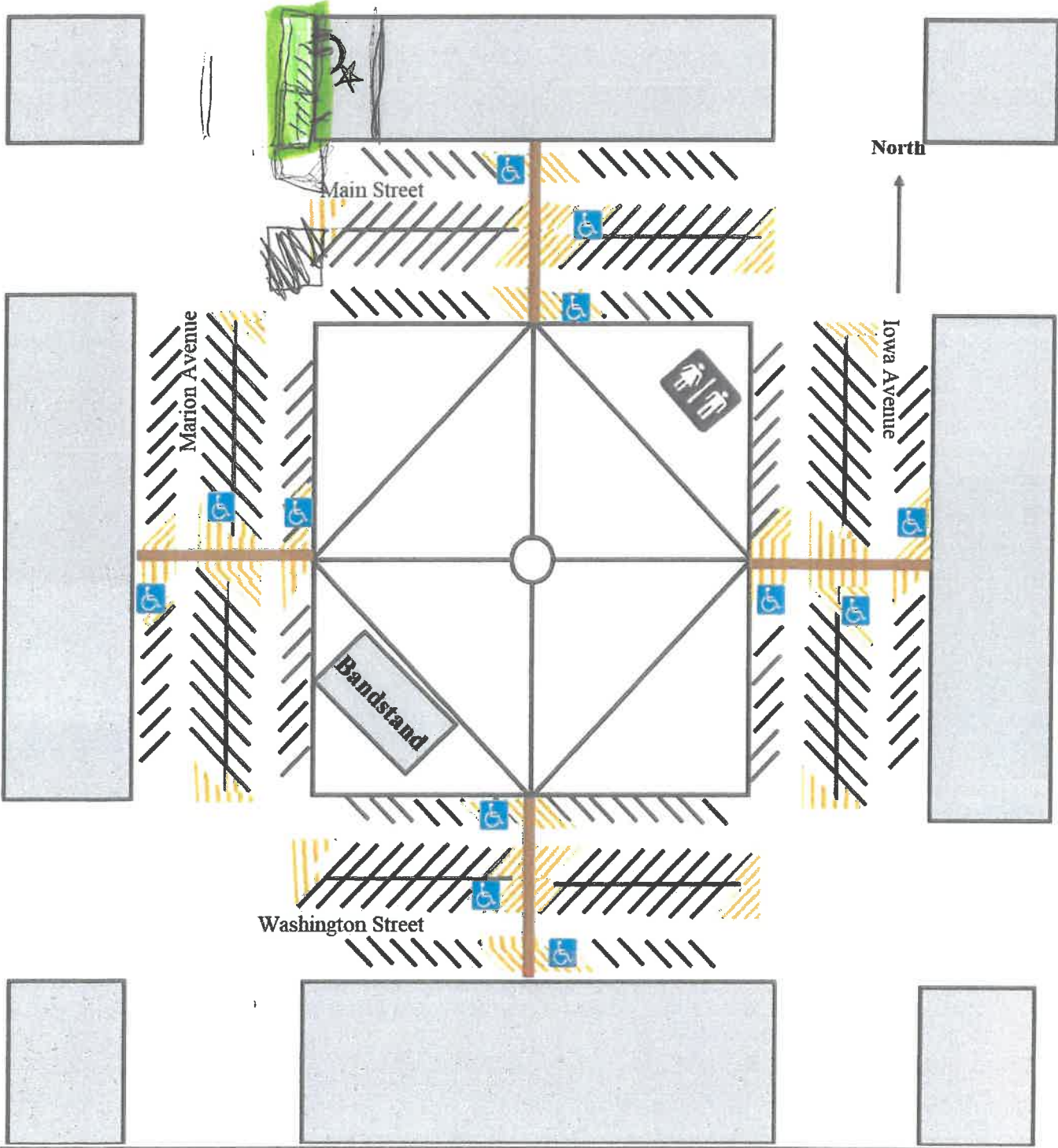



CERTIFICATE OF LIABILITY INSURANCE

DATE (MM/DD/YYYY)
08/15/2022

THIS CERTIFICATE IS ISSUED AS A MATTER OF INFORMATION ONLY AND CONFERS NO RIGHTS UPON THE CERTIFICATE HOLDER. THIS CERTIFICATE DOES NOT AFFIRMATIVELY OR NEGATIVELY AMEND, EXTEND OR ALTER THE COVERAGE AFFORDED BY THE POLICIES BELOW. THIS CERTIFICATE OF INSURANCE DOES NOT CONSTITUTE A CONTRACT BETWEEN THE ISSUING INSURER(S), AUTHORIZED REPRESENTATIVE OR PRODUCER, AND THE CERTIFICATE HOLDER.

IMPORTANT: If the certificate holder is an ADDITIONAL INSURED, the policy(ies) must have ADDITIONAL INSURED provisions or be endorsed. If SUBROGATION IS WAIVED, subject to the terms and conditions of the policy, certain policies may require an endorsement. A statement on this certificate does not confer rights to the certificate holder in lieu of such endorsement(s).

PRODUCER FARM BUREAU FINANCIAL SERVICES
409 CREEKSIDE DRIVE
FAIRFAX, IA 52228

CONTACT NAME: TRAVIS CLEMEN

PHONE (A/C, No, Ext): 319-846-2100

FAX (A/C, No):

E-MAIL ADDRESS:

INSURER(S) AFFORDING COVERAGE

NAIC #

INSURER A : Farm Bureau Property Casualty Ins. Co.

13773

INSURED MAMA LLAMAS BARN LLC
124 W MAIN STREET
WASHINGTON, IA 52353

INSURER B :

INSURER C :

INSURER D :

INSURER E :

INSURER F :

COVERAGES

CERTIFICATE NUMBER:

REVISION NUMBER:

THIS IS TO CERTIFY THAT THE POLICIES OF INSURANCE LISTED BELOW HAVE BEEN ISSUED TO THE INSURED NAMED ABOVE FOR THE POLICY PERIOD INDICATED. NOTWITHSTANDING ANY REQUIREMENT, TERM OR CONDITION OF ANY CONTRACT OR OTHER DOCUMENT WITH RESPECT TO WHICH THIS CERTIFICATE MAY BE ISSUED OR MAY PERTAIN, THE INSURANCE AFFORDED BY THE POLICIES DESCRIBED HEREIN IS SUBJECT TO ALL THE TERMS, EXCLUSIONS AND CONDITIONS OF SUCH POLICIES. LIMITS SHOWN MAY HAVE BEEN REDUCED BY PAID CLAIMS.

INSR LTR	TYPE OF INSURANCE	ADDL SUBR INSD WVD	POLICY NUMBER	POLICY EFF (MM/DD/YYYY)	POLICY EXP (MM/DD/YYYY)	LIMITS
A	<input checked="" type="checkbox"/> COMMERCIAL GENERAL LIABILITY <input checked="" type="checkbox"/> CLAIMS-MADE <input type="checkbox"/> OCCUR GEN'L AGGREGATE LIMIT APPLIES PER: <input type="checkbox"/> POLICY <input type="checkbox"/> PRO-JECT <input type="checkbox"/> LOC OTHER:		CPP6080109	08/01/2022	08/01/2023	EACH OCCURRENCE \$ 1,000,000 DAMAGE TO RENTED PREMISES (Ea occurrence) \$ 100,000 MED EXP (Any one person) \$ 5000 PERSONAL & ADV INJURY \$ 1,000,000 GENERAL AGGREGATE \$ 2,000,000 PRODUCTS - COMP/OP AGG \$ 2,000,000 \$
	AUTOMOBILE LIABILITY <input type="checkbox"/> ANY AUTO <input type="checkbox"/> OWNED AUTOS ONLY <input type="checkbox"/> SCHEDULED AUTOS <input type="checkbox"/> HIRED AUTOS ONLY <input type="checkbox"/> NON-OWNED AUTOS ONLY					COMBINED SINGLE LIMIT (Ea accident) \$ BODILY INJURY (Per person) \$ BODILY INJURY (Per accident) \$ PROPERTY DAMAGE (Per accident) \$ \$
	<input type="checkbox"/> UMBRELLA LIAB <input type="checkbox"/> OCCUR <input type="checkbox"/> EXCESS LIAB <input type="checkbox"/> CLAIMS-MADE DED RETENTION \$					EACH OCCURRENCE \$ AGGREGATE \$ \$
	WORKERS COMPENSATION AND EMPLOYERS' LIABILITY ANY PROPRIETOR/PARTNER/EXECUTIVE OFFICER/MEMBER EXCLUDED? (Mandatory in NH) If yes, describe under DESCRIPTION OF OPERATIONS below					PER STATUTE OTH-ER E.L. EACH ACCIDENT \$ E.L. DISEASE - EA EMPLOYEE \$ E.L. DISEASE - POLICY LIMIT \$

DESCRIPTION OF OPERATIONS / LOCATIONS / VEHICLES (ACORD 101, Additional Remarks Schedule, may be attached if more space is required)

CERTIFICATE HOLDER

CITY OF WASHINGTON
215 E WASHINGTON STREET
WASHINGTON, IA 52353

CANCELLATION

SHOULD ANY OF THE ABOVE DESCRIBED POLICIES BE CANCELLED BEFORE THE EXPIRATION DATE THEREOF, NOTICE WILL BE DELIVERED IN ACCORDANCE WITH THE POLICY PROVISIONS.

AUTHORIZED REPRESENTATIVE

TRAVIS CLEMEN

© 1988-2016 ACORD CORPORATION. All rights reserved.

**CITY OF WASHINGTON, IOWA
CLAIMS REPORT
AUGUST 16, 2022**

POLICE	COBB OIL CO, INC.	FUEL	2,356.35
	ACE-N-MORE	KEYS & BATTERIES	69.15
	AMAZON CAPITAL SERVICES	WEOPONS SAFE-NEW HIRE	90.68
	BDH TECHNOLOGY LLC	OFFICE SOFTWARE/CONTRACT	701.88
	BOUND TREE MEDICAL, LLC	GLOVES PPE	269.90
	BRDECKA, MIA	ILEA EQUIPMENT- REIMBURSEM	14.83
	CAPPER CHRYSLER DODGE JEEP RAM	FUEL PUMP REPLACEMENT	1,061.23
	GALLS LLC	UNIFORM - B ALTENHOFEN/VEST	450.98
	IGRAPHIX, INC	B CARDS- BRDECKA	50.00
	INTOXIMETERS INC	PBT SUPPLIES	84.00
	IOWA LAW ENFORCMT ACADEMY	INSTRUCTOR RECERT/TRAINING	250.00
	KCTC	PHONE & INTERNET	364.16
	MARCO, INC.	COPIER	389.54
	MOORE'S BP AMOCO, INC.	FORD FUSION- TOW & STORING	345.00
	VERIZON WIRELESS	WIRELESS SERVICE	1,026.89
		TOTAL	7,524.59
FIRE	ALL AMERICAN PEST CONTROL	PEST CONTROL	32.50
	ARMSTRONG HEATING & AIR CONDITIONING I	A/C REPAIR	2,289.50
	ARNOLD MOTOR SUPPLY	AIR FILTER	15.75
	CENTRAL IOWA DISTRIBUTING	SUPPLIES	181.00
	COBB OIL CO, INC.	FUEL	284.56
	KCTC	PHONE & INTERNET	206.94
	LEET'S REFRIGERATION	ICE MACHINE REPAIR	179.50
	STAR FOOD SERV EQUIPMENT	OVEN REPAIR	92.29
	VERIZON WIRELESS	WIRELESS SERVICE	291.25
		TOTAL	3,573.29
	DEVELOPMENT SERVICES	ACE-N-MORE	BATTERY / SUPPLIES
VERIZON WIRELESS		WIRELESS SERVICE	179.39
		TOTAL	434.98
LIBRARY	ACCESS SYSTEMS	COPIER MAINTENANCE	16.22
	ACE-N-MORE	JANITORIAL SUPPLIES	8.99
	ALL AMERICAN PEST CONTROL	PEST CONTROL	40.00
	ALLIANT ENERGY	ALLIANT ENERGY	1,805.07
	BAKER & TAYLOR	LIBRARY MATERIALS	747.47
	BLACKSTONE PUBLISHING	AUDIOBOOKS	30.95
	CENTRAL IOWA DISTRIBUTING	SUPPLIES	144.00
	DEMCO INC	OFFICE SUPPLIES	174.62
	FRANK MILLARD & CO	BACKFLOW PREVENTER TEST	300.00
	KCII	ADVERTISING	113.54
	KCTC	PHONE & INTERNET	449.47
	OVERDRIVE, INC.	DIGITAL MATERIALS	476.91
	STANLEY, CORINNE	GUEST SPEAKER	40.00
	STAPLES BUSINESS ADVANTAGE	OFFICE SUPPLIES	159.89
	VALENTINE, TAMMY	MILEAGE FOR HOMEBOUND	15.63
	WCDC INC	WINDOW WASHING	40.00
		TOTAL	4,562.76
	PARKS	ACE-N-MORE	SUPPLIES
ALLIANT ENERGY		ALLIANT ENERGY	1,713.36
COBB OIL CO, INC.		FUEL	695.67
COBB OIL CO., INC-BP ONE TRIP		FUEL	50.31
FAREWAY STORES		FLOWERS	29.98
KCTC		PHONE & INTERNET	331.47
WASH CHAMBER OF COMMERCE		CHAMBER GOLF	175.00
		TOTAL	4,040.10
POOL	ALLIANT ENERGY	ALLIANT ENERGY	4,883.12
	KCTC	PHONE & INTERNET	85.94
		TOTAL	4,969.06
CEMETERY	ACE-N-MORE	LIGHT BULBS/BATTERIES/SPRAYER	696.14

	ALLIANT ENERGY	ALLIANT ENERGY	21.80
	COBB OIL CO, INC.	FUEL	460.63
	KCTC	PHONE & INTERNET	164.70
	PRODUCTIVITY PLUS	BACKHOE PARTS	120.50
	WASHINGTON LUMBER	JOINT AND CRACK SEALER	92.96
		TOTAL	1,556.73
FINANCIAL ADMIN	ACE-N-MORE	SUPPLIES	22.76
	ALL AMERICAN PEST CONTROL	PEST CONTROL	32.50
	ALLIANT ENERGY	ALLIANT ENERGY	21.77
	FRANK MILLARD & CO	BACKFLOW PREVENTER TEST	175.00
	GOOGLE LLC	EMAIL SUBSCRIPTION	396.00
	IOWA STATE UNIVERSITY	ST & ROADS WORKSHOP/CONFER	220.00
	KCII	ADVERTISING	223.54
	KCTC	PHONE & INTERNET	932.82
	PACE PAYMENT SYSTEMS	DC/CC ADMIN FEE	20.00
	PITNEY BOWES GLOBAL FINANCIAL SERVICES	POSTAGE METER REFILL	1,005.00
	ROSIEN, JARON	MILEAGE REIMBURSEMENT	165.00
	STOREY KENWORTHY/MATT PARROTT	PAYABLE CHECK FORMS	561.07
	VERIZON WIRELESS	WIRELESS SERVICE	86.47
	WASH CHAMBER OF COMMERCE	CHAMBER GOLF	325.00
	WASH COUNTY MINIBUS	AUGUST LOST	22,613.53
	WMPF GROUP LLC	ADVERTISING	240.01
		TOTAL	27,040.47
AIRPORT	ACE-N-MORE	SUPPLIES	23.98
	BAUTISTA MIRANDA, YOLANDA	JULY CLEANING	375.00
	BROOKHART ELECTRIC, INC	HAND DRYER INSTALLS/WELL PUMP	1,111.65
	KCII	ADVERTISING	113.54
	KLEOPFER LAWN CARE LLC	SPRAYING	830.00
	LEET'S REFRIGERATION	SERVICE ICE MACHINE	390.86
	TITAN AVIATION FUELS	FUEL	95,719.07
	VERIZON WIRELESS	WIRELESS SERVICE	46.46
	VETTER'S INC-CULLIGAN WATER	AIRPORT WATER	36.96
	WEST LAWN CARE	MOWING AIRPORT	1,510.00
	WINDSTREAM IOWA COMMUNICATIONS	AUGUST SERVICE	198.27
		TOTAL	100,355.79
ROAD USE	ACE-N-MORE	SCREEN FOR PAINTING	19.98
	ARNOLD MOTOR SUPPLY	PARTS	84.31
	CASH-N-CARRY CHEMICALS LLC	WEED KILLER	190.00
	COBB OIL CO, INC.	FUEL	511.89
	COBB OIL CO., INC-BP ONE TRIP	FUEL	153.01
	CORRIDOR CAREERS	EMPLOYMENT ADVERTISING	289.00
	GIERKE ROBINSON CO., INC	ADA PADS FOR DOWNTOWN	756.60
	IDEAL READY MIX	STREET PATCHES	3,882.50
	IOWA PRISON INDUSTRIES	SIGN	55.55
	L L PELLING CO	PRE-MIX	1,785.77
	MID-AM RES. CHEMICAL CORP	GASKET MAKER	521.51
	O'REILLY AUTOMOTIVE INC	SERVICE VALVE WRENCH	12.00
	RIVER PRODUCTS	SAND	665.25
	S & G MATERIALS	ASPHALT MILLINGS	342.39
	WASHINGTON LUMBER	LUMBER FOR CONCRETE FORMS	40.35
	WELLINGTON, EARL	TRANSMISSION FUSING MACHIN	411.55
		TOTAL	9,721.66
STREET LIGHTING	ALLIANT ENERGY	ALLIANT ENERGY	11,835.48
		TOTAL	11,835.48
HOTEL/MOTEL TAX	VORTEX DIGITAL BUSINESS SOLUTIONS, INC	WEBSITE MAINTENANCE	442.10
		TOTAL	442.10
CAPITAL PROJECTS	ULINE	5TH STREET PROJ-SAFETY BOLLARD	171.71
		TOTAL	171.71
SIDEWALK REPAIR	HASKINS, KEVIN	SIDEWALK REPLACEMENT/REPAI	704.00
		TOTAL	704.00

RESIDENTIAL DEVELOP	WASH CO RECORDER	RECORDING SUBDIVISION PLAT	27.00
		TOTAL	27.00
TREE COMMITTEE	IGRAPHIX, INC	TREE COMMITTEE SUPPLIES	20.00
	WMPF GROUP LLC	TREE COMMITTEE ADVERTISING	230.60
		TOTAL	250.60
WATER PLANT	ALL AMERICAN PEST CONTROL	PEST CONTROL	35.00
	ALLIANT ENERGY	ALLIANT ENERGY	22,829.98
	COBB OIL CO, INC.	FUEL	78.87
	GLOBAL PAYMENTS	DC/CC ADMIN FEE	2,177.96
	IA DEPT OF REVENUE	WET TAX	8,730.72
	KCTC	PHONE & INTERNET	165.62
	VERIZON WIRELESS	WIRELESS SERVICE	46.46
	WATER SOLUTIONS UNLIMITED	CHEMICALS	8,615.42
		TOTAL	42,680.03
WATER DISTRIBUTION	ACE-N-MORE	TOOLING	152.63
	ALLIANT ENERGY	ALLIANT ENERGY	23.41
	CINTAS FIRST AID & SAFETY	FIRST AID SUPPLIES	49.60
	COBB OIL CO, INC.	BUCKETS FOR DRAINING COOLA	22.50
	COBB OIL CO., INC-BP ONE TRIP	FUEL	0.06
	CORRIDOR CAREERS	EMPLOYMENT ADVERTISING	50.00
	DETROIT INDUSTRIAL TOOL	GLOVES	267.33
	DOUDS STONE LLC	ROADSTONE & CLEANSTONE	844.97
	E H WACHS COMPANY	VALVE WRENCH REPAIR	297.31
	FRANK MILLARD & CO	BACKFLOW PREVENTER TEST	112.50
	KCTC	PHONE & INTERNET	99.81
	MARTIN EQUIPMENT OF IA-IL	BACKHOE OIL SAMPLE- WARRANT	467.59
	QUAD CITIES WINWATER	HYDRANTS	5,500.00
	SCHIMBERG CO.	CURB STOPS	4,878.90
	USA BLUEBOOK	NEW PIN LOCATOR	777.57
	VERIZON WIRELESS	WIRELESS SERVICE	210.91
	WASHINGTON LUMBER	DRI-CRETE	47.60
		TOTAL	13,802.69
SEWER PLANT	ALLIANT ENERGY	ALLIANT ENERGY	536.50
	ARMSTRONG HEATING & AIR CONDITIONING I	A/C SERVICE	185.00
	CINTAS FIRST AID & SAFETY	FIRST AID SUPPLIES	30.54
	COBB OIL CO, INC.	FUEL	370.90
	EUROFINS ENVIRONMENT TESTING NC	CERTIFIED TESTING	1,444.80
	IA DEPT OF NATURAL RESOURCES	NPDES ANNUAL FEE	1,275.00
	IA DEPT OF REVENUE	SALES TAX	2,417.17
	MIDWEST OVERHEAD CRANE	ANNUAL INSPECTION FOR CRAN	915.60
	ONSITE SERVICES SOLUTIONS, LLC	WORK ON D,O. METERS	425.00
	USA BLUEBOOK	PARTS FOR CLEANING	339.93
	VERIZON WIRELESS	WIRELESS SERVICE	134.38
	WASH CHAMBER OF COMMERCE	CHAMBER GOLF	175.00
	WINDSTREAM IOWA COMMUNICATIONS	AUGUST SERVICE	286.68
		TOTAL	8,536.50
SEWER COLLECTION	ALLIANT ENERGY	ALLIANT ENERGY	1,128.97
	COBB OIL CO, INC.	FUEL	455.96
	CORRIDOR CAREERS	EMPLOYMENT ADVERTISING	50.00
	KCTC	PHONE & INTERNET	99.81
	VACSTAR	VAC TRAILER REPAIR	300.00
	VERIZON WIRELESS	WIRELESS SERVICE	126.44
	WASHINGTON DISCOUNT TIRE	TIRES	746.52
		TOTAL	2,907.70
SANITATION	JOHNSON COUNTY REFUSE INC	REFUSE AND RECYCLING SERVI	48,570.50
		TOTAL	48,570.50
SELF INSURANCE	EMPLOYEE BENEFIT SYSTEMS	EBS ADMIN FEE	399.84
		TOTAL	399.84
		TOTAL	294,107.58

CITY OF WASHINGTON, IOWA
MONTH TO DATE TREASURERS REPORT
JULY 31, 2022

FUND	7/1/2022		REVENUES NOT YET RECEIVED	7/31/2022	
	BEGINNING CASH-BALANCE	M-T-D REVENUES		M-T-D EXPENDITURES	EXPENSES NOT YET EXPENDED
001-GENERAL FUND	1,022,613.53	70,216.30	-	549,018.60	543,811.23
002-AIRPORT FUND	358,953.40	84,592.51	-	62,716.90	380,829.01
010-CHAMBER REIMBURSEMENT	7,902.24	7,779.67	-	10,349.23	5,332.68
011-MAIN STREET REIMBURSEMENT	2,118.03	4,286.07	-	4,027.15	2,376.95
012-WEDG REIMBURSEMENT	2,584.82	8,060.82	-	7,469.32	3,176.32
050-DOWNTOWN INCENTIVE GRANT	163,473.15	-	-	-	163,473.15
110-ROAD USE	504,763.55	78,003.18	-	50,830.27	531,936.46
112-EMPLOYEE BENEFITS	-	3,965.85	-	3,965.85	-
113-LIABILITY INSURANCE	-	-	-	-	-
114-EMERGENCY LEVY	-	360.96	-	360.96	-
121-LOCAL OPTION SALES TAX	-	90,454.10	-	90,454.10	-
122-LOST DEBT SERVICE	-	67,840.57	-	-	67,840.57
123-LOST DEBT SERVICE RESERVE	79,170.00	-	-	-	79,170.00
124-HOTEL/MOTEL TAX	122,812.24	-	-	6,647.59	116,164.65
125-UNIF COMM UR-NE IND	-	-	-	-	-
126-SE RES UR	-	-	-	-	-
127-UNIF COMM UR - BRIARWOOD	-	-	-	-	-
128-URBAN RENEWAL AREA #3B/D	-	-	-	-	-
129-SC RES UR	-	-	-	-	-
130-URBAN RENEWAL AREA #3D	-	-	-	-	-
131-URBAN RENEWAL AREA #4	-	-	-	-	-
132-UNIF COMM UR - EBD	-	-	-	-	-
133-UNIF COMM UR-IRE	-	-	-	-	-
134-DOWNTOWN COMM UR	-	273.66	-	-	273.66
145-HOUSING REHABILITATION	35,643.82	16,735.00	-	1,875.00	50,503.82
146-LMI TIF SET-ASIDE	151,266.11	-	-	-	151,266.11
200-DEBT SERVICE	56,467.63	4,751.61	-	13,750.00	47,469.24
300-CAPITAL EQUIPMENT	147,053.70	-	-	-	147,053.70
301-CAPITAL PROJECTS FUND	437,301.66	556,749.67	-	266,408.15	727,643.18
303-WWTP CAPITAL PROJ FUND	-	-	-	-	-
305-RIVERBOAT FOUND CAP PROJ	398,997.29	-	-	-	398,997.29
308-INDUSTRIAL DEVELOPMENT	255,745.84	17,337.23	-	8,595.64	264,487.43
309-MUNICIPAL BUILDING	-	-	-	-	-
310-WELLNESS PARK	6,353.50	-	-	-	6,353.50
311-SIDEWALK REPAIR & REPLACE	90,642.86	-	-	992.00	89,650.86
312-TREE REMOVAL & REPLACE	23,988.59	-	-	-	23,988.59
315-RESIDENTIAL DEVELOPMENT	278,930.49	-	-	4,335.28	274,595.21
317-ARPA CAPITAL PROJECTS	523,763.25	532.07	-	-	524,295.32
325-BUILDING & FACILITY MAINT	13,524.60	-	-	-	13,524.60
510-MUNICIPAL BAND	4,743.03	-	-	-	4,743.03
520-DOG PARK	4,443.11	-	-	-	4,443.11
530-TREE COMMITTEE	11,322.84	2,100.00	-	130.50	13,292.34
535-NEIGHBORHOOD PRIDE	-	-	-	-	-
540-POLICE FORFEITURE	4,590.86	-	-	-	4,590.86
541-K-9 PROGRAM	2,809.30	50.00	-	40.75	2,818.55
545-SAFETY FUND	2,636.89	1,000.00	-	-	3,636.89
550-PARK GIFT	32,135.30	1,332.49	-	-	33,467.79
570-LIBRARY GIFT	354,318.68	462.79	-	2,224.94	352,556.53
580-CEMETERY GIFT	7,433.00	-	-	-	7,433.00
590-CABLE COMMISSION	-	-	-	-	-
600-WATER UTILITY	495,798.75	217,952.96	-	114,631.92	599,119.79
601-WATER DEPOSIT FUND	30,835.00	1,950.00	-	2,250.00	30,535.00
602-WATER SINKING	-	-	-	-	-
603-WATER CAPITAL PROJECTS	-	-	-	76,164.70	(76,164.70)
610-SANITARY SEWER	188,444.50	189,093.26	-	114,530.19	263,007.57
612-SEWER SINKING	-	-	-	-	-
613-SEWER CAPITAL PROJECTS	-	-	-	8,512.66	(8,512.66)
670-SANITATION	67,068.52	53,828.45	-	48,967.36	71,929.61
910-LIBRARY TRUST	-	-	-	-	-
950-SELF INSURANCE	463,148.16	466.31	-	740.07	462,874.40
951-UNEMPLOYMENT SELF INS	73,505.00	29.35	-	2,740.88	70,793.47
TOTAL BALANCE	6,427,303.24	1,480,204.88	-	1,452,730.01	6,454,778.11

Cash in Bank - Pooled Cash

		<u>Interest Rate</u>
Wash St. Bank - Operating Account	1,299,212.39 (1)	0.20%
Wash St. Bank - Airport Fuel Account	-	
Cash in Drawer	350.00	N/A
Investment in IPAIT	556,965.88	0.20%
Wash St - Farm Mgmt Acct	199,959.16	
Wash St Bank - CD 1/14/2019	521,031.02	0.65%
Wash St Bank - CD 08/30/2018	268,930.33	0.65%
Wash St Bank - ISC Account	3,608,329.33	1.70%
TOTAL CASH IN BANK	6,454,778.11	

(1) Washington State Bank	1,552,916.34
Outstanding Deposits & Checks/Wages payable	(253,703.95)
	<u>1,299,212.39</u>

CITY OF WASHINGTON, IOWA
YEAR TO DATE TREASURERS REPORT
JULY 31, 2022

FUND	7/1/2022	Y-T-D	REVENUES NOT	Y-T-D	EXPENSES NOT	7/31/2022
	BEGINNING					REVENUES
	CASH BALANCE					BALANCE
001-GENERAL FUND	1,022,613.53	70,216.30	-	549,018.60	-	543,811.23
002-AIRPORT FUND	358,953.40	84,592.51	-	62,716.90	-	380,829.01
010-CHAMBER REIMBURSEMENT	7,902.24	7,779.67	-	10,349.23	-	5,332.68
011-MAIN STREET REIMBURSEMENT	2,118.03	4,286.07	-	4,027.15	-	2,376.95
012-WEDG REIMBURSEMENT	2,584.82	8,060.82	-	7,469.32	-	3,176.32
050-DOWNTOWN INCENTIVE GRANT	163,473.15	-	-	-	-	163,473.15
110-ROAD USE	504,763.55	78,003.18	-	50,830.27	-	531,936.46
112-EMPLOYEE BENEFITS	-	3,965.85	-	3,965.85	-	-
113-LIABILITY INSURANCE	-	-	-	-	-	-
114-EMERGENCY LEVY	-	360.96	-	360.96	-	-
121-LOCAL OPTION SALES TAX	-	90,454.10	-	90,454.10	-	-
122-LOST DEBT SERVICE	-	67,840.57	-	-	-	67,840.57
123-LOST DEBT SERVICE RESERVE	79,170.00	-	-	-	-	79,170.00
124-HOTEL/MOTEL TAX	122,812.24	-	-	6,647.59	-	116,164.65
125-UNIF COMM UR-NE IND	-	-	-	-	-	-
126-SE RES UR	-	-	-	-	-	-
127-UNIF COMM UR - BRIARWOOD	-	-	-	-	-	-
128-URBAN RENEWAL AREA #3B/D	-	-	-	-	-	-
129-SC RES UR	-	-	-	-	-	-
130-URBAN RENEWAL AREA #3D	-	-	-	-	-	-
131-URBAN RENEWAL AREA #4	-	-	-	-	-	-
132-UNIF COMM UR - EBD	-	-	-	-	-	-
133-UNIF COMM UR-IRE	-	-	-	-	-	-
134-DOWNTOWN COMM UR	-	273.66	-	-	-	273.66
145-HOUSING REHABILITATION	35,643.82	16,735.00	-	1,875.00	-	50,503.82
146-LMI TIF SET-ASIDE	151,266.11	-	-	-	-	151,266.11
200-DEBT SERVICE	56,467.63	4,751.61	-	13,750.00	-	47,469.24
300-CAPITAL EQUIPMENT	147,053.70	-	-	-	-	147,053.70
301-CAPITAL PROJECTS FUND	437,301.66	556,749.67	-	266,408.15	-	727,643.18
303-WWTP CAPITAL PROJ FUND	-	-	-	-	-	-
305-RIVERBOAT FOUND CAP PROJ	398,997.29	-	-	-	-	398,997.29
308-INDUSTRIAL DEVELOPMENT	255,745.84	17,337.23	-	8,595.64	-	264,487.43
309-MUNICIPAL BUILDING	-	-	-	-	-	-
310-WELLNESS PARK	6,353.50	-	-	-	-	6,353.50
311-SIDEWALK REPAIR & REPLACE	90,642.86	-	-	992.00	-	89,650.86
312-TREE REMOVAL & REPLACE	23,988.59	-	-	-	-	23,988.59
315-RESIDENTIAL DEVELOPMENT	278,930.49	-	-	4,335.28	-	274,595.21
317-ARPA CAPITAL PROJECTS	523,763.25	532.07	-	-	-	524,295.32
325-BUILDING & FACILITY MAINT	13,524.60	-	-	-	-	13,524.60
510-MUNICIPAL BAND	4,743.03	-	-	-	-	4,743.03
520-DOG PARK	4,443.11	-	-	-	-	4,443.11
530-TREE COMMITTEE	11,322.84	2,100.00	-	130.50	-	13,292.34
535-NEIGHBORHOOD PRIDE	-	-	-	-	-	-
540-POLICE FORFEITURE	4,590.86	-	-	-	-	4,590.86
541-K-9 PROGRAM	2,809.30	50.00	-	40.75	-	2,818.55
545-SAFETY FUND	2,636.89	1,000.00	-	-	-	3,636.89
550-PARK GIFT	32,135.30	1,332.49	-	-	-	33,467.79
570-LIBRARY GIFT	354,318.68	462.79	-	2,224.94	-	352,556.53
580-CEMETERY GIFT	7,433.00	-	-	-	-	7,433.00
590-CABLE COMMISSION	-	-	-	-	-	-
600-WATER UTILITY	495,798.75	217,952.96	-	114,631.92	-	599,119.79
601-WATER DEPOSIT FUND	30,835.00	1,950.00	-	2,250.00	-	30,535.00
602-WATER SINKING	-	-	-	-	-	-
603-WATER CAPITAL PROJECTS	-	-	-	76,164.70	-	(76,164.70)
610-SANITARY SEWER	188,444.50	189,093.26	-	114,530.19	-	263,007.57
612-SEWER SINKING	-	-	-	-	-	-
613-SEWER CAPITAL PROJECTS	-	-	-	8,512.66	-	(8,512.66)
670-SANITATION	67,068.52	53,828.45	-	48,967.36	-	71,929.61
910-LIBRARY TRUST	-	-	-	-	-	-
950-SELF INSURANCE	463,148.16	466.31	-	740.07	-	462,874.40
951-UNEMPLOYMENT SELF INS	73,505.00	29.35	-	2,740.88	-	70,793.47
TOTAL BALANCE	6,427,303.24	1,480,204.88	-	1,452,730.01	-	6,454,778.11

Cash in Bank - Pooled Cash

		<u>Interest Rate</u>
Wash St. Bank - Operating Account	1,299,212.39 (1)	0.20%
Wash St. Bank - Airport Fuel Account	-	
Cash in Drawer	350.00	N/A
Investment in IPAIT	556,965.88	0.20%
Wash St - Farm Mgmt Acct	199,959.16	
Wash St Bank - CD 1/14/2019	521,031.02	0.65%
Wash St Bank - CD 08/30/2018	268,930.33	0.65%
Wash St Bank - ISC Account	3,608,329.33	1.70%
TOTAL CASH IN BANK	6,454,778.11	

(1) Washington State Bank	1,552,916.34
Outstanding Deposits & Checks/Wages payable	(253,703.95)
TOTAL	1,299,212.39

NOTICE OF PUBLIC HEARING

NOTICE OF PUBLIC HEARING ON PLANS, SPECIFICATIONS, ESTIMATE OF COST AND FORM OF CONTRACT FOR CERTAIN INFRASTRUCTURE FOR 2022 WATER MAIN IMPROVEMENT PROJECT AND SETTING A DATE FOR RECEIVING OF BIDS

The City Council of the City of Washington, Iowa, will hold a public hearing at 6:00 p.m. on Tuesday, August 16th, 2022 in the Washington City Council Chambers at 215 E. Washington Street in the Washington. Said public hearing shall be to consider the approval of the plans, specifications, estimate of cost and form of contract for certain infrastructure for the 2022 Water Main Improvement Project. All interested persons are invited to attend and be heard on the proposed plans, specifications, estimate of cost and form of contract for said Project. The City shall receive sealed bids on this Project until 11 a.m. on September 13, 2022. The City Council shall consider and award bid at 6:00 p.m. September 20th, 2022, at the regular session of the City Council. Further information on this matter may be obtained by contacting the Washington City Clerk.

/s/Sally Y. Hart, City Clerk,
by direction of the City Council

RESOLUTION 2022-__

**A RESOLUTION ADOPTING PLANS, SPECIFICATIONS, FORM OF CONTRACT,
AND ESTIMATE OF COSTS FOR THE 2022 WATER MAIN IMPROVEMENT
PROJECT**

WHEREAS, FOX Strand Engineering has prepared plans, specifications, form of contract and estimate of cost for the improvement of certain public streets described in general as “2022 Water Main Improvement Project” and,

WHEREAS, notice of public hearing on plans, specifications, form of contract, and estimate of cost for said improvement was published on August 11, 2022 required by law.

NOW, THEREFORE, BE IT RESOLVED BY THE CITY COUNCIL OF THE CITY OF WASHINGTON, IOWA:

Section 1. That the plans, specifications, form of contract, and estimate of cost are hereby approved as the plans, specifications, form of contract, and estimate of cost for said public improvements, as described in the preamble of this Resolution.

PASSED AND APPROVED this ___ day of August, 2022.

Jaron P. Rosien, Mayor

ATTEST:

Sally Y. Hart, City Clerk

RESOLUTION NO. _____

**A RESOLUTION AUTHORIZING LEVY,
ASSESSMENT, AND COLLECTION OF COSTS TO
THE WASHINGTON COUNTY TREASURER.**

WHEREAS, the City of Washington, Iowa is empowered to levy, assess, and collect costs of improvement and removal of debris against the abutting property owner,

WHEREAS, trash and junk was removed from the following listed property owners:

The property of Triska, Violet. located at 206 W 6th St. for the amount of \$250.00. Legal description (04 01 M M YOUNGS 2ND ADD W 42 FT) Parcel Number (1117154004).

WHEREAS, due notice was given to the above property owners that said amount would be assessed to the property if payment was not made or an appeal was not made,

NOW, THEREFORE, BE IT RESOLVED BY THE COUNCIL OF THE CITY OF WASHINGTON, IOWA that the City Clerk be instructed to certify the above delinquent payment to be assessed against said property as listed above and that the City Clerk certify a copy of this resolution to the Washington County Treasurer.

Passed and Approved this 16th day of August, 2022.

Jaron Rosien, Mayor

Attest:

Sally Y. Hart, City Clerk

*Jaron P. Rosien, Mayor
Deanna McCusker, City Administrator
Kelsey Brown, Finance Director
Sally Y. Hart, City Clerk
Kevin Olson, City Attorney*



*City of Washington
215 East Washington Street
Washington, Iowa 52353
(319) 653-6584 Phone
(319) 653-5273 Fax*

August 11, 2022

Iowa Economic Development Authority
1963 Bell Avenue, Suite 200
Des Moines, IA 50315

Re: Challenge Grant Application – Renovation of Koller Plus Building

Dear Grant Selection Team:

The City of Washington supports the Main Street Washington application to the IEDA for a Main Street Challenge Grant. We further state that representatives of the City Council and the City Building and Zoning Official have reviewed the project proposal.

We further agree that all historically significant properties submitted for consideration in this application will comply with the Secretary of Interior's standards for historic property rehabilitation.

Sincerely,

Jaron P. Rosien
Mayor

Deanna McCusker
City Administrator

Maddie Widmer
President, Main Street Washington

DESIGN CONCEPT PROPOSAL

August 10, 2022
Koller + Plus, 206 S Iowa Ave, Washington, IA
Project #07422



Design recommendations are based upon field inspection during the site visit and/or information provided by the owner/tenant and are conceptual only. They are not intended for construction purposes. Additional consultation, or the use of specialized consultants including a licensed architect or engineer, may be required for additional design development and for individual issues or concerns. Prior to beginning any work, consult with local officials to ensure compliance with local codes and ordinances.



Existing Building



Historic Photographs: 1950s (L) and 1971 (R)

NOTES

- This drawing proposes façade improvements to the Koller + Plus building at 206 S Iowa Ave to highlight and complement the existing historic character. The upper façade of the building remains relatively intact with the oriel window and metal cornice significant character defining features. While the storefront has been altered over time, this concept proposes a historically appropriate storefront configuration that provides a more cohesive look to the façade.
- The most substantial changes occur at the storefront. Remove the existing awning and infill storefront materials. Replace storefront windows and brick below with a paneled bulkhead like shown. The building historically had glass transom window openings above the storefront windows. Rebuild the transom glass panel (which was presumably removed at some point) to bring the storefront back to its original height. While altering the interior ceiling may not be feasible at this time to fully expose the transom panel, the transom panel can be used as a sign band, similar to the example photo provided (at right).
- Replace the gray brick on the vertical pier between the storefront windows and upper story door. Work with the project contractor or mason to source a similar tan brick to match the upper façade as



closely as possible. Alternatively, painting the pier tan to match the upper brick can help it blend in and provide a more cohesive appearance. Install a small, operable awning between the transom and storefront windows to provide sun shading for the west-facing storefront.

- While storefront improvements are underway, consider replacing the stepped entrance with a sloped or ramped approach to provide a more accessible entry.
- Work on the upper façade is largely maintenance of the existing materials. Clean the brick using the gentlest means possible to remove areas of staining (refer to [Preservation Brief #1](#) for appropriate methods), and repoint mortar joints as needed (refer to [Preservation Brief #2](#) and engage a mason well-versed in historic masonry).
- Remove the cladding from the bay window and install new trim to match that shown in the historic photos and the paneled appearance proposed for the storefront bulkhead.
- Check the cornice for any loose or missing elements that could be potential areas for water infiltration; repair and seal as needed.
- Paint the storefront, bay window and cornice like shown to highlight different architectural elements of the building. A sample color palette is shown below.
- A revised upper story floor plan (previous drawing #06216) is also included to incorporate the owner's desired changes.

Main Street Iowa recommendations follow the [Secretary of Interior's Standards](#) for the rehabilitation of historic buildings. Additional information on technical guidance can be found in [Preservation Briefs](#) prepared by the National Park Service.

COLOR SCHEME

Benjamin Moore paint colors and Sunbrella awning fabric is shown here for reference. Appearance of color samples will vary depending on computer screen or printer – view actual samples for color matching.



#HC-155



#1464



#999



#CW-180



#4946-0000

Main Street Iowa design staff is available to provide continued assistance as the project progresses. Please contact Maia Fiala Jessen (515.348.6179 or maia.jessen@iowaeda.com) or Sarah Lembke (515.348.6181 or sarah.lembke@iowaeda.com) with any questions, requests for technical information or project updates.



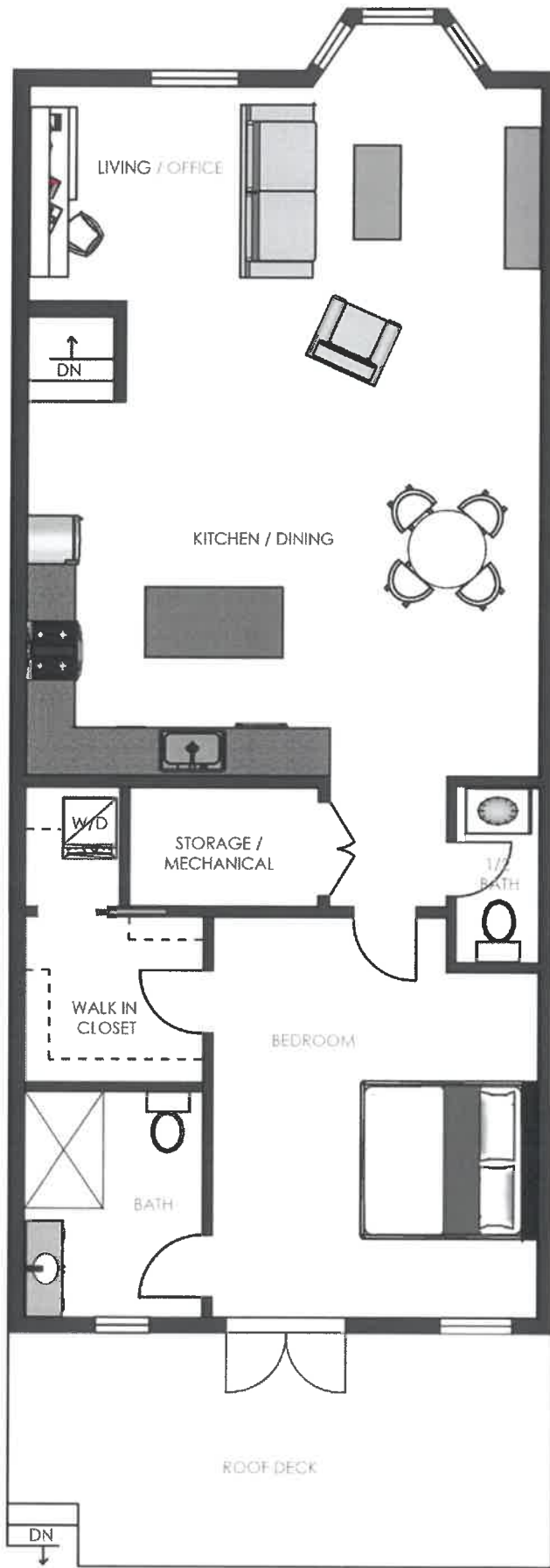

RESOLUTION NO. 2022-

A RESOLUTION ENDORSING AN APPLICATION FOR GRANT FUNDS

WHEREAS, the Wellness Park promotes outdoor recreation and is a regional draw for activities; and

WHEREAS, the Wellness Park facilities would be able to provide more outdoor recreational space for children of all ages with a play structure on an accessible surface; and

WHEREAS, the City Council and important community stakeholders have strongly supported moving forward on this project; and

WHEREAS, the City wishes to apply for funds from the Washington County Riverboat Foundation; and

WHEREAS, the play structure, surface, installation, and concrete border is estimated to cost approximately \$345,000; and

NOW, THEREFORE, BE IT RESOLVED BY THE CITY COUNCIL OF THE CITY OF WASHINGTON, IOWA:

Section 1. The City Council endorses the submission of an application for competitive grant funds to the Washington County Riverboat Foundation in the amount of \$150,000 for the Wellness Park Playground Project.

Section 2. The City Council states its commitment in partnering with local non-profit organizations to increase the regional use of the Wellness Park for outdoor recreational activities.

Section 3. The City Council states its commitment to \$100,000 in local matching funds for the project.

PASSED AND APPROVED this ____ day of August, 2022.

Jaron P. Rosien, Mayor

ATTEST:

Sally Y. Hart, City Clerk



Development Services
215 E. Washington St.
Washington, IA 52353
319.653.6584 ext. 124

Memo

To: City Council
From: Jeff Duwa-Building and Zoning Official
Date: 8/11/2022
Re: Preliminary Plat for Wiley Subdivision Third Addition and Major Site Plan for Wiley Subdivision Third Addition

Issue

Review and consider the Preliminary Plat for Wiley Subdivision Third Addition, then Major Site Plan for Wiley Subdivision Third Addition.

Background

Greg Wiley is wanting to sell Parcel 1116400062 which is the farm field on the east side of Wal-Mart. The buyer would like to subdivide this property into 2 buildable lots and one storm water detention lot. This would be a proposed site for an Urgent Care facility on lot 1 initially and designed to add another business in the future. On Tuesday, August 9, 2022, the City of Washington's Planning and Zoning Commission met to review and discuss the Preliminary Plat for Wiley Subdivision Third Addition, then the Major Site Plan for Wiley Subdivision Third Addition.

Recommendation

The City of Washington's Planning and Zoning Commission recommends that the City of Washington's City Council approve the Preliminary Plat for Wiley Subdivision Third Addition and the Major Site Plan for Wiley Subdivision Third Addition.

PRELIMINARY PLAT WILEY SUBDIVISION, THIRD ADDITION WASHINGTON, WASHINGTON COUNTY, IOWA

5.71 ACRES



CIVIL ENGINEERS
LAND PLANNERS
LAND SURVEYORS
LANDSCAPE ARCHITECTS
ENVIRONMENTAL SPECIALISTS

1917 S. GILBERT ST.
IOWA CITY, IOWA 52240
(319) 351-8200
www.mmsconsultants.com

Date: Revision
07-19-2022 REVISED LOT 1 - PVA

PRELIMINARY PLAT

WILEY SUBDIVISION, THIRD ADDITION

WASHINGTON
WASHINGTON COUNTY
IOWA

MMS CONSULTANTS, INC.

Date: **06-29-2022**
Designed by: PVA Plans Book No. 1388
Drawn by: JEM Scale: 1"=50'
Checked by: PVA Issue No. **1**
Project No. 11324-001
of 1

ZONING AND SETBACK REQUIREMENTS
CURRENT ZONING: B-2 (GENERAL BUSINESS DISTRICT)
FRONT YARD SETBACK: NONE
SIDE YARD SETBACK: NONE
REAR YARD SETBACK: 8 FEET
MINIMUM LOT AREA: NONE
MINIMUM LOT WIDTH: NONE
MAXIMUM BUILDING HEIGHT: NONE
NO VARIANCES FROM ZONING REGULATIONS ARE BEING REQUESTED

LOCATION: AUDITOR PARCEL "V" BEING A PORTION OF THE SOUTHEAST QUARTER OF THE SOUTHEAST QUARTER OF SECTION 16-72N-R7W OF THE 5TH P.M. FOUND 1801 MONUMENT BOOK 11 AT PAGE 405	SUBDIVISION: PALM DEVELOPMENT PARTNERS 2334 HIGHWAY 22 NORTH YAMA, TN 38386 PROPRIETOR OR OWNER: J. GREGORY & LOUISE A. B. WILEY 5474 VERT 42 WASHINGTON, IOWA 52353 SUBDIVIDER ATTORNEY: SHELLEY WATKINS RMT ATTORNEYS AT LAW 2021 2327 AVENUE SOUTH NASHVILLE, TN 37211 DOCUMENT RETURN INFORMATION: LAND SURVEYOR
LAND SURVEYOR: RICHARD A. HOWORTH, P.L.S. MMS CONSULTANTS INC. 1917 SOUTH GILBERT STREET IOWA CITY, IOWA 52240 PHONE: 319-351-8202	

DESCRIPTION - WILEY SUBDIVISION, THIRD ADDITION
Auditor Parcel "V" in Washington, Iowa, is accordance with the Plat thereof recorded in Book 21 at Page 1022 of the Records of the Washington County Recorder's Office, said Auditor Parcel V contains 6.71 Acres, and is subject to easements and restrictions of record.

STANDARD LEGEND AND NOTES	
---	PROPERTY A/E BOUNDARY LINES
---	COMPRESSORIAL SECTION LINES
---	RIGHT-OF-WAY LINES
---	EXISTING RIGHT-OF-WAY LINES
---	EXISTING CENTER LINES
---	EXISTING CENTER LINES
---	LOT LINES, PLATTED OR BY DEED
---	PROPOSED EASEMENT LINES
---	EXISTING EASEMENT LINES
---	ENCUMBRANCE
---	RECORDED DIMENSIONS
---	CURVE SEGMENT NUMBER
(R)	PROPOSED
(B)	EXISTING
---	POWER POLE
---	POWER POLE W/DROP
---	POWER POLE W/TURNS
---	POWER POLE W/ANCHOR
---	LIGHT POLE
---	SANITARY MANHOLE
---	FIRE HYDRANT
---	WATER VALVE
---	DRAINAGE MANHOLE
---	CURB W/LET
---	FENCE LINE
---	EXISTING SANITARY SEWER
---	PROPOSED SANITARY SEWER
---	EXISTING STORM SEWER
---	PROPOSED STORM SEWER
---	WATER LINES
---	ELECTRICAL LINES
---	TELEPHONE LINES
---	CABLE LINES
---	CONTOUR LINES (1' INTERVAL)
---	PROPOSED GRASS
---	EXISTING TREE LINE
---	EXISTING EVERGREEN TREES & SHRUBS
---	EXISTING DECIDUOUS TREE & SHRUBS

THE ACTUAL SIZE AND LOCATION OF ALL PROPOSED FACILITIES SHALL BE NOTED WITH CONSTRUCTION DOCUMENTS, WHICH ARE TO BE PREPARED AND SUBMITTED SUBSEQUENT TO THE APPROVAL OF THIS DOCUMENT.

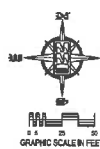
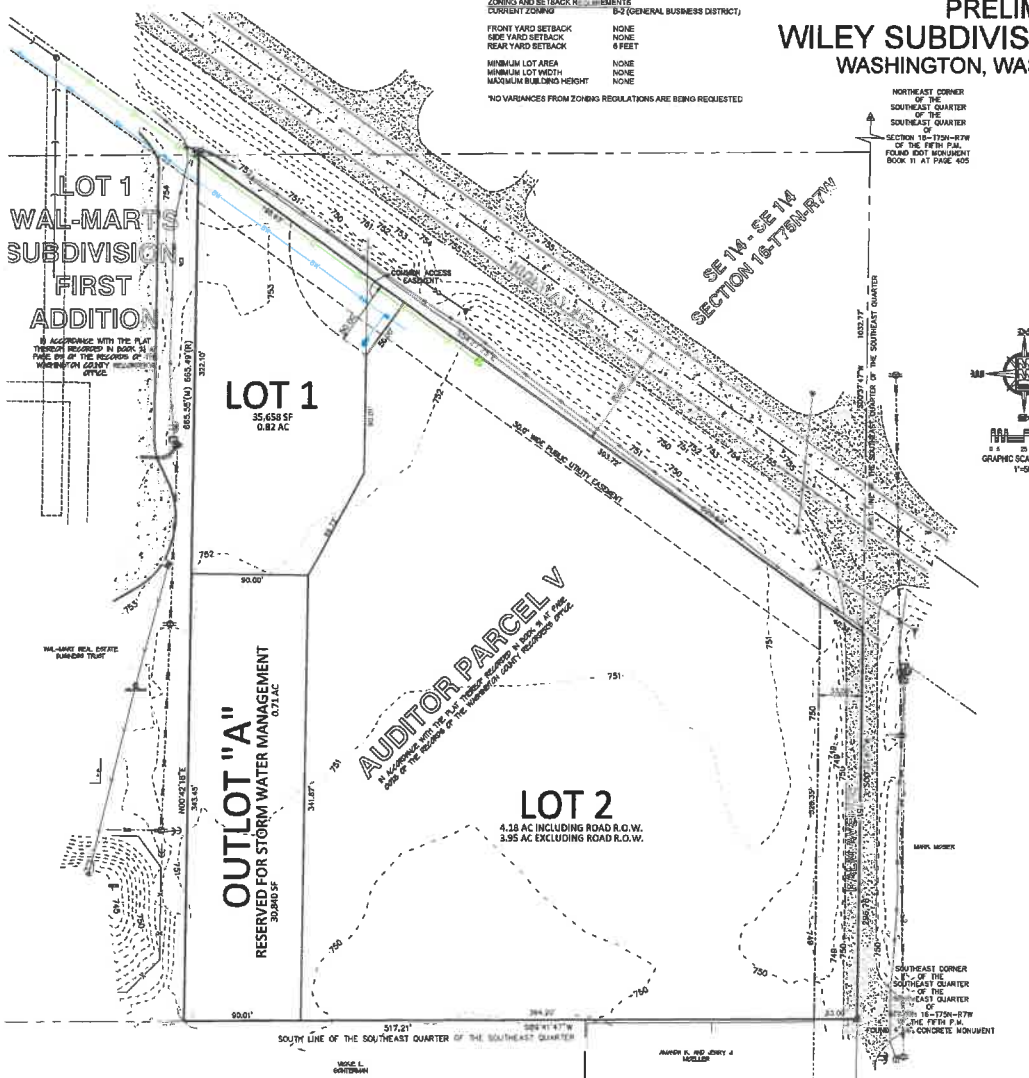

LOT 1
WAL-MART'S
SUBDIVISION,
FIRST
ADDITION

IN ACCORDANCE WITH THE PLAT THEREON RECORDED IN BOOK 31, PAGE 819 OF THE RECORDS OF THE WASHINGTON COUNTY RECORDER'S OFFICE.

74-AMM BLD. EASE. PARKING TRAIL

WILEY L. CHRISTMAN

AUDITOR A. RE. JERRY J. MOELLER

UTILITY COMPANY CONTACTS	SYMBOL	PHONE NO.
TELEPHONE	NATIONAL COOPERATIVE TELEPHONE 1776 JAMES STREET	319-338-2000
NATURAL GAS	HAUNT ENERGY 1776 JAMES STREET	1-800-255-4398
ELECTRICITY	HAUNT ENERGY 1776 JAMES STREET	1-800-255-4398
TELEPHONE & CABLE TV	HAUNT ENERGY 1776 JAMES STREET	319-338-2000
COMMS/CONNECTION	THE COMMUNICATIONS NETWORK 1776 JAMES STREET	1-800-479-2640
WATER	CITY OF WASHINGTON 1776 JAMES STREET	319-338-2547
SEWER	CITY OF WASHINGTON 1776 JAMES STREET	319-338-2547

SITE PLAN QUICK VISIT URGENT CARE WASHINGTON, IOWA

SUBMITTER: MCM CONSULTANTS, INC. 1176 JAMES STREET WASHINGTON, IOWA 52581
 OWNER: THE COMMUNICATIONS NETWORK 1776 JAMES STREET WASHINGTON, IOWA 52581
 DESIGNER: MCM CONSULTANTS, INC. 1176 JAMES STREET WASHINGTON, IOWA 52581
 DATE: 07/13/2022

- REVISIONS**
- C128 SITE LAYOUT AND DIMENSION PLAN
 - C129 SITE SHEDDING AND DRAINAGE PLAN
 - C141 DETAILED GRASSING PLAN
 - C120 SANITARY PLAN AND PROFILE
 - C140 WATER UTILITY PLAN AND OFFSITE RICHMOND RUN AND PROFILE (SOUTH)
 - C130 OFFSITE RICHMOND RUN AND PROFILE (NORTH)
 - C131 STORAGE UTILITY PLAN AND OFFSITE RICHMOND RUN AND PROFILE (NORTH)
 - C132 STORAGE UTILITY PLAN AND OFFSITE RICHMOND RUN AND PROFILE (SOUTH)
 - C133 LANDSCAPE PLAN

STANDARD LEGEND AND NOTES

SYMBOL	DESCRIPTION	SYMBOL	DESCRIPTION
(Symbol)	PROPOSED LOT 1	(Symbol)	PROPOSED LOT 2
(Symbol)	PROPOSED LOT 3	(Symbol)	PROPOSED LOT 4
(Symbol)	PROPOSED LOT 5	(Symbol)	PROPOSED LOT 6
(Symbol)	PROPOSED LOT 7	(Symbol)	PROPOSED LOT 8
(Symbol)	PROPOSED LOT 9	(Symbol)	PROPOSED LOT 10
(Symbol)	PROPOSED LOT 11	(Symbol)	PROPOSED LOT 12
(Symbol)	PROPOSED LOT 13	(Symbol)	PROPOSED LOT 14
(Symbol)	PROPOSED LOT 15	(Symbol)	PROPOSED LOT 16
(Symbol)	PROPOSED LOT 17	(Symbol)	PROPOSED LOT 18
(Symbol)	PROPOSED LOT 19	(Symbol)	PROPOSED LOT 20
(Symbol)	PROPOSED LOT 21	(Symbol)	PROPOSED LOT 22
(Symbol)	PROPOSED LOT 23	(Symbol)	PROPOSED LOT 24
(Symbol)	PROPOSED LOT 25	(Symbol)	PROPOSED LOT 26
(Symbol)	PROPOSED LOT 27	(Symbol)	PROPOSED LOT 28
(Symbol)	PROPOSED LOT 29	(Symbol)	PROPOSED LOT 30
(Symbol)	PROPOSED LOT 31	(Symbol)	PROPOSED LOT 32
(Symbol)	PROPOSED LOT 33	(Symbol)	PROPOSED LOT 34
(Symbol)	PROPOSED LOT 35	(Symbol)	PROPOSED LOT 36
(Symbol)	PROPOSED LOT 37	(Symbol)	PROPOSED LOT 38
(Symbol)	PROPOSED LOT 39	(Symbol)	PROPOSED LOT 40
(Symbol)	PROPOSED LOT 41	(Symbol)	PROPOSED LOT 42
(Symbol)	PROPOSED LOT 43	(Symbol)	PROPOSED LOT 44
(Symbol)	PROPOSED LOT 45	(Symbol)	PROPOSED LOT 46
(Symbol)	PROPOSED LOT 47	(Symbol)	PROPOSED LOT 48
(Symbol)	PROPOSED LOT 49	(Symbol)	PROPOSED LOT 50
(Symbol)	PROPOSED LOT 51	(Symbol)	PROPOSED LOT 52
(Symbol)	PROPOSED LOT 53	(Symbol)	PROPOSED LOT 54
(Symbol)	PROPOSED LOT 55	(Symbol)	PROPOSED LOT 56
(Symbol)	PROPOSED LOT 57	(Symbol)	PROPOSED LOT 58
(Symbol)	PROPOSED LOT 59	(Symbol)	PROPOSED LOT 60
(Symbol)	PROPOSED LOT 61	(Symbol)	PROPOSED LOT 62
(Symbol)	PROPOSED LOT 63	(Symbol)	PROPOSED LOT 64
(Symbol)	PROPOSED LOT 65	(Symbol)	PROPOSED LOT 66
(Symbol)	PROPOSED LOT 67	(Symbol)	PROPOSED LOT 68
(Symbol)	PROPOSED LOT 69	(Symbol)	PROPOSED LOT 70
(Symbol)	PROPOSED LOT 71	(Symbol)	PROPOSED LOT 72
(Symbol)	PROPOSED LOT 73	(Symbol)	PROPOSED LOT 74
(Symbol)	PROPOSED LOT 75	(Symbol)	PROPOSED LOT 76
(Symbol)	PROPOSED LOT 77	(Symbol)	PROPOSED LOT 78
(Symbol)	PROPOSED LOT 79	(Symbol)	PROPOSED LOT 80
(Symbol)	PROPOSED LOT 81	(Symbol)	PROPOSED LOT 82
(Symbol)	PROPOSED LOT 83	(Symbol)	PROPOSED LOT 84
(Symbol)	PROPOSED LOT 85	(Symbol)	PROPOSED LOT 86
(Symbol)	PROPOSED LOT 87	(Symbol)	PROPOSED LOT 88
(Symbol)	PROPOSED LOT 89	(Symbol)	PROPOSED LOT 90
(Symbol)	PROPOSED LOT 91	(Symbol)	PROPOSED LOT 92
(Symbol)	PROPOSED LOT 93	(Symbol)	PROPOSED LOT 94
(Symbol)	PROPOSED LOT 95	(Symbol)	PROPOSED LOT 96
(Symbol)	PROPOSED LOT 97	(Symbol)	PROPOSED LOT 98
(Symbol)	PROPOSED LOT 99	(Symbol)	PROPOSED LOT 100

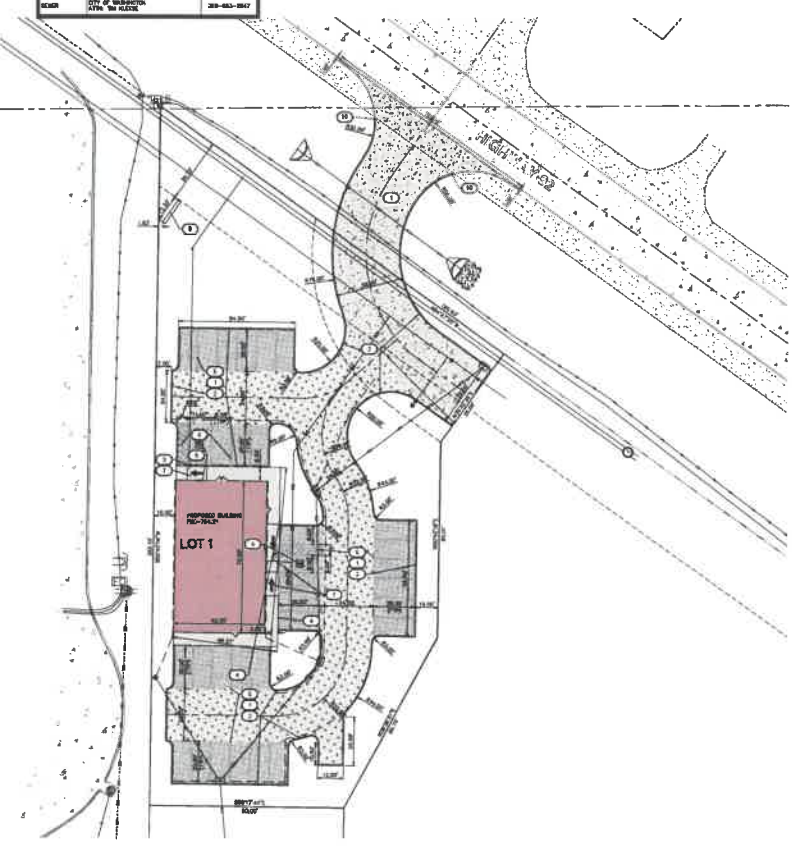

LEGAL DESCRIPTION:
 1/2 SEC. 36, T28N, R23W, S4E, DIST. 15, IOWA
 1/2 SEC. 37, T28N, R23W, S4E, DIST. 15, IOWA

GENERAL NOTES:
 1. THE CONTRACTOR SHALL COORDINATE WITH UTILITY PROVIDERS FOR ANY REQUIRED RELOCATION OR EXTENSION OF EXISTING UTILITIES.

GENERAL NOTES:
 2. THE CONTRACTOR SHALL MAINTAIN ACCESS TO ALL EXISTING UTILITIES.

GENERAL NOTES:
 3. THE CONTRACTOR SHALL MAINTAIN ACCESS TO ALL EXISTING UTILITIES.

GENERAL NOTES:
 4. THE CONTRACTOR SHALL MAINTAIN ACCESS TO ALL EXISTING UTILITIES.

GENERAL NOTES:
 5. THE CONTRACTOR SHALL MAINTAIN ACCESS TO ALL EXISTING UTILITIES.

GENERAL NOTES:
 6. THE CONTRACTOR SHALL MAINTAIN ACCESS TO ALL EXISTING UTILITIES.

GENERAL NOTES:
 7. THE CONTRACTOR SHALL MAINTAIN ACCESS TO ALL EXISTING UTILITIES.

GENERAL NOTES:
 8. THE CONTRACTOR SHALL MAINTAIN ACCESS TO ALL EXISTING UTILITIES.

GENERAL NOTES:
 9. THE CONTRACTOR SHALL MAINTAIN ACCESS TO ALL EXISTING UTILITIES.

GENERAL NOTES:
 10. THE CONTRACTOR SHALL MAINTAIN ACCESS TO ALL EXISTING UTILITIES.

PERMITS REQUIRED:

PERMIT TYPE	ISSUED BY	ISSUE DATE
GRASSING PERMIT	10	10/10/20
WATER PERMIT	10	10/10/20
SEWER PERMIT	10	10/10/20
LANDSCAPING PERMIT	10	10/10/20

CONTRACTOR SHALL COORDINATE WITH UTILITY PROVIDERS FOR ANY REQUIRED RELOCATION OR EXTENSION OF EXISTING UTILITIES.



IOWA ONE CALL
 1-800-333-3333
 www.iowaonecall.com

PLANNING BOARD

1. I hereby certify that the information furnished hereon was prepared by the person or persons named herein, and that the same is true and correct to the best of my knowledge and belief.

DATE: 07/13/2022

BY: [Signature]

TITLE: [Title]

MCM
 CONSULTANTS, INC.
 CIVIL ENGINEERS
 LAND PLANNERS
 LAND SURVEYORS
 LANDSCAPE ARCHITECTS
 ENVIRONMENTAL SPECIALISTS
 1176 JAMES ST.
 WASHINGTON, IOWA 52581
 WWW.MCMCONSULTANTS.COM

SITE LAYOUT AND DIMENSION PLAN

QUICK VISIT URGENT CARE

WASHINGTON
WASHINGTON COUNTY
IOWA

MCM CONSULTANTS, INC.

Project No: 07/13/2022

Designed By: JMM

Checked By: JMM

Date: 07/13/2022

Project No: C120

11324-001

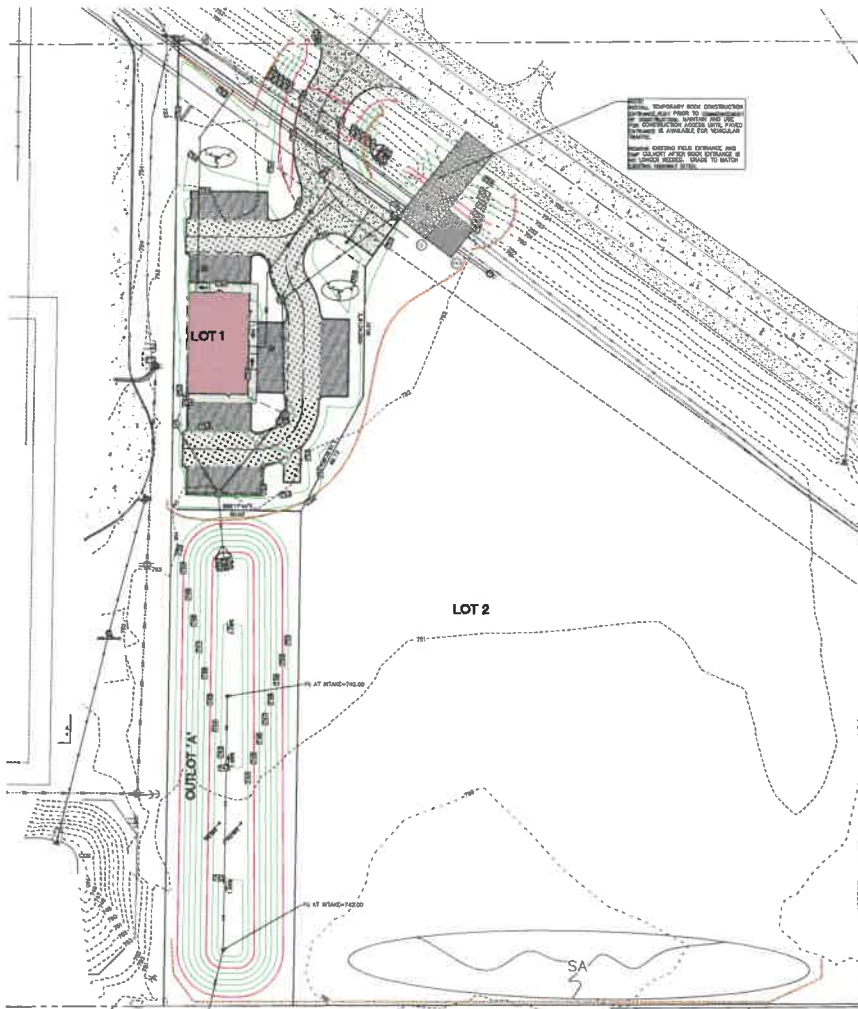

EROSION CONTROL LEGEND

	TEMPORARY SOIL CONSTRUCTION EROSION CONTROL		REINFORCED SILT FENCE
	TEMPORARY PARKING AND STORAGE		DIRECTION OF CHANNEL FLOW
	TEMPORARY SEEDING		SILT FENCE PROTECTION
	FILTER SOCK (SODS, STRIPS, INSPECTION POINT, ETC.)		FILTER SOCK
	FILTER SOCK WITH PROTECTION		FILTER SOCK
	FILTER SOCK WITH SODS AT SILT RAMP		FILTER SOCK

THE ABOVE LEGEND SHALL BE KEPT ON THE PROJECT THROUGHOUT CONSTRUCTION. IF A CHANGE OCCURS IN ANY OF THESE SYMBOLS, THE USER SHALL NOTIFY THE ENGINEER IMMEDIATELY. THE USER SHALL MAINTAIN RECORDS OF ALL CHANGES TO THE LEGEND. THE USER SHALL BE RESPONSIBLE FOR CORRECTING ANY AND ALL ERRORS IN THE LEGEND. THE USER SHALL BE RESPONSIBLE FOR CORRECTING ANY AND ALL ERRORS IN THE LEGEND. THE USER SHALL BE RESPONSIBLE FOR CORRECTING ANY AND ALL ERRORS IN THE LEGEND.

STANDARD LEGEND AND NOTES

	PROPOSED EROSION CONTROL LINE		EXISTING EROSION CONTROL LINE
	PROPOSED TOP OF ROAD		EXISTING TOP OF ROAD
	PROPOSED RIGHT OF WAY		EXISTING RIGHT OF WAY
	PROPOSED UTILITY LINE		EXISTING UTILITY LINE
	PROPOSED ELEVATION		EXISTING ELEVATION
	PROPOSED SPOT ELEVATION		EXISTING SPOT ELEVATION
	PROPOSED CONTOUR LINE		EXISTING CONTOUR LINE
	PROPOSED SPOT ELEVATION		EXISTING SPOT ELEVATION
	PROPOSED SPOT ELEVATION		EXISTING SPOT ELEVATION
	PROPOSED SPOT ELEVATION		EXISTING SPOT ELEVATION
	PROPOSED SPOT ELEVATION		EXISTING SPOT ELEVATION

THE ABOVE LEGEND SHALL BE KEPT ON THE PROJECT THROUGHOUT CONSTRUCTION. IF A CHANGE OCCURS IN ANY OF THESE SYMBOLS, THE USER SHALL NOTIFY THE ENGINEER IMMEDIATELY. THE USER SHALL MAINTAIN RECORDS OF ALL CHANGES TO THE LEGEND. THE USER SHALL BE RESPONSIBLE FOR CORRECTING ANY AND ALL ERRORS IN THE LEGEND. THE USER SHALL BE RESPONSIBLE FOR CORRECTING ANY AND ALL ERRORS IN THE LEGEND. THE USER SHALL BE RESPONSIBLE FOR CORRECTING ANY AND ALL ERRORS IN THE LEGEND.

GRADING LEGEND

	PROPOSED TOP OF ROAD		EXISTING TOP OF ROAD
	PROPOSED RIGHT OF WAY		EXISTING RIGHT OF WAY
	PROPOSED ELEVATION		EXISTING ELEVATION
	PROPOSED SPOT ELEVATION		EXISTING SPOT ELEVATION
	PROPOSED CONTOUR LINE		EXISTING CONTOUR LINE
	PROPOSED SPOT ELEVATION		EXISTING SPOT ELEVATION
	PROPOSED SPOT ELEVATION		EXISTING SPOT ELEVATION

REINFORCED SILT FENCE DETAIL

IF SOIL MUST BE MOVED AND PLACED ON THE OTHER SIDE OF THE FENCE, THE FENCE SHALL BE REINFORCED WITH A MINIMUM OF 2 LAYERS OF GEOTEXTILE. THE REINFORCING SHALL BE INSTALLED IN THE MIDDLE OF THE FENCE. THE REINFORCING SHALL BE INSTALLED IN THE MIDDLE OF THE FENCE. THE REINFORCING SHALL BE INSTALLED IN THE MIDDLE OF THE FENCE. THE REINFORCING SHALL BE INSTALLED IN THE MIDDLE OF THE FENCE. THE REINFORCING SHALL BE INSTALLED IN THE MIDDLE OF THE FENCE.

IOWA ONE CALL

WASHINGTON WASHINGTON COUNTY IOWA



MMS ENGINEERS
 LAND PLANNERS
 LAND SURVEYORS
 LANDSCAPE ARCHITECTS
 ENVIRONMENTAL SPECIALISTS

1111 S. BELMONT ST.
 IOWA CITY, IOWA 52242
 515-271-1111

OVERALL SITE SWPPP AND GRADING PLAN

QUICK VISIT URGENT CARE

WASHINGTON WASHINGTON COUNTY IOWA

MMS CONSULTANTS, INC.
 07/13/2022
 11324-001

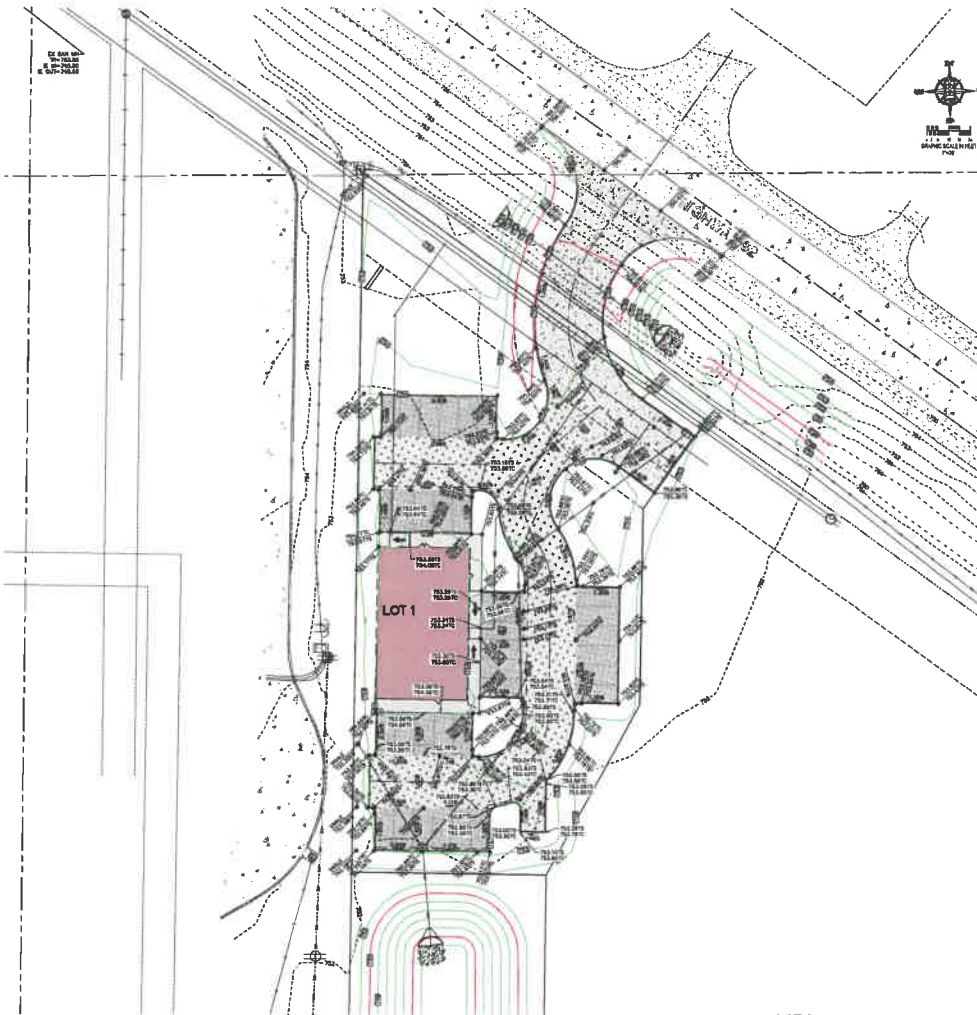

EROSION CONTROL LEGEND

	TEMPORARY STOCK PILES		TEMPORARY EROSION CONTROL
	TEMPORARY FENCING		TEMPORARY SEEDING
	TEMPORARY MULCH		TEMPORARY SILT FENCE
	TEMPORARY SEDIMENTATION		TEMPORARY EROSION CONTROL

STANDARD LEGEND AND NOTES

	EROSION CONTROL		SEEDING
	MULCH		SILT FENCE
	SEDIMENTATION		EROSION CONTROL
	FENCING		SEEDING

GRADING LEGEND

	EXISTING SURFACE
	TOP OF FILL
	TOP OF CUT
	TOP OF SLOPE

REINFORCED SILT FENCE DETAIL

NOTES:

- 1. FILL MUST BE COMPACTED TO 95% RELATIVE DENSITY.
- 2. FILL MUST BE PLACED IN 6" LAYERS.
- 3. FILL MUST BE PLACED TO A MINIMUM OF 18" ABOVE THE FINISH GRADE.
- 4. FILL MUST BE PLACED TO A MINIMUM OF 18" FROM THE EDGE OF THE FILL.
- 5. FILL MUST BE PLACED TO A MINIMUM OF 18" FROM THE EDGE OF THE FILL.

LEGEND:

- EXISTING SURFACE
- TOP OF FILL
- TOP OF CUT
- TOP OF SLOPE

IOWA ONE CALL

WASHTON COUNTY IOWA

QUICK VISIT URGENT CARE

MMS CONSULTANTS, INC.
07/3/2022
11324-001

MMS

CIVIL ENGINEERS
LAND PLANNERS
LAND SURVEYORS
LANDSCAPE ARCHITECTS
ENVIRONMENTAL SPECIALISTS

11324-001

DATE: 07/03/2022
BY: MMS

DETAILED GRADING PLAN

QUICK VISIT URGENT CARE
WASHINGTON COUNTY IOWA

MMS CONSULTANTS, INC.
07/3/2022
11324-001



CIVIL ENGINEERS
LAND SURVEYORS
LANDSCAPE ARCHITECTS
ENVIRONMENTAL SPECIALISTS
WATER QUALITY
SOIL CONSTRUCTION
UTILITY MANAGEMENT

191701 - 12/11/21 - 12/11/21

**SANITARY AND
WATER UTILITY
PLAN**

**QUICK VISIT
URGENT CARE**

WASHINGTON
WASHINGTON COUNTY
IOWA

MMS CONSULTANTS, INC.
07/13/2022
Project No. 1588
Scale: 1"=100'
Date: 11/18/2021

11324-001

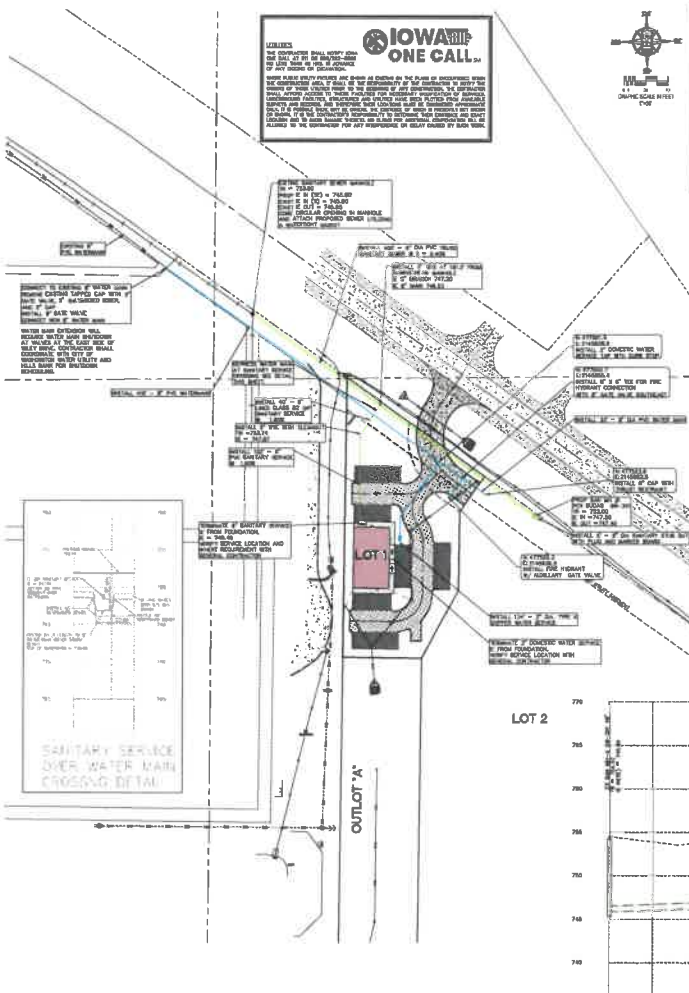

PAVING CONSTRUCTION NOTES

- 1. PAVEMENT STRUCTURE SHALL BE IN ACCORDANCE WITH STATE SPECIFICATIONS (SEE IOWA CODE 816.0040).
- 2. A MINIMUM OF 4" OF ASPHALT SHALL BE USED FOR ALL PAVEMENTS UNLESS OTHERWISE SPECIFIED. ASPHALT SHALL BE IN ACCORDANCE WITH IOWA CODE 816.0040.
- 3. ALL PAVEMENT SHALL BE CONSTRUCTED TO A FINISH GRADE WITHIN THE TOLERANCES SPECIFIED IN THE SPECIFICATIONS.
- 4. ALL PAVEMENT SHALL BE CONSTRUCTED TO A FINISH GRADE WITHIN THE TOLERANCES SPECIFIED IN THE SPECIFICATIONS.
- 5. ALL PAVEMENT SHALL BE CONSTRUCTED TO A FINISH GRADE WITHIN THE TOLERANCES SPECIFIED IN THE SPECIFICATIONS.

STANDARD LEGEND AND NOTES

- 1. WATER SUPPLY LINE (1" - 4")
- 2. SANITARY SEWER LINE (12" - 30")
- 3. STORM SEWER LINE (18" - 36")
- 4. FIRE WATER LINE (2" - 6")
- 5. ...

STORM SEWER AND SUB-SURFACE CONSTRUCTION NOTES

- 1. STORM SEWER SHALL BE CONSTRUCTED TO A FINISH GRADE WITHIN THE TOLERANCES SPECIFIED IN THE SPECIFICATIONS. STORM SEWER SHALL BE CONSTRUCTED TO A FINISH GRADE WITHIN THE TOLERANCES SPECIFIED IN THE SPECIFICATIONS.
- 2. STORM SEWER SHALL BE CONSTRUCTED TO A FINISH GRADE WITHIN THE TOLERANCES SPECIFIED IN THE SPECIFICATIONS. STORM SEWER SHALL BE CONSTRUCTED TO A FINISH GRADE WITHIN THE TOLERANCES SPECIFIED IN THE SPECIFICATIONS.
- 3. STORM SEWER SHALL BE CONSTRUCTED TO A FINISH GRADE WITHIN THE TOLERANCES SPECIFIED IN THE SPECIFICATIONS. STORM SEWER SHALL BE CONSTRUCTED TO A FINISH GRADE WITHIN THE TOLERANCES SPECIFIED IN THE SPECIFICATIONS.

STORM SEWER AND SUB-SURFACE CONSTRUCTION NOTES

- 1. STORM SEWER SHALL BE CONSTRUCTED TO A FINISH GRADE WITHIN THE TOLERANCES SPECIFIED IN THE SPECIFICATIONS. STORM SEWER SHALL BE CONSTRUCTED TO A FINISH GRADE WITHIN THE TOLERANCES SPECIFIED IN THE SPECIFICATIONS.
- 2. STORM SEWER SHALL BE CONSTRUCTED TO A FINISH GRADE WITHIN THE TOLERANCES SPECIFIED IN THE SPECIFICATIONS. STORM SEWER SHALL BE CONSTRUCTED TO A FINISH GRADE WITHIN THE TOLERANCES SPECIFIED IN THE SPECIFICATIONS.
- 3. STORM SEWER SHALL BE CONSTRUCTED TO A FINISH GRADE WITHIN THE TOLERANCES SPECIFIED IN THE SPECIFICATIONS. STORM SEWER SHALL BE CONSTRUCTED TO A FINISH GRADE WITHIN THE TOLERANCES SPECIFIED IN THE SPECIFICATIONS.

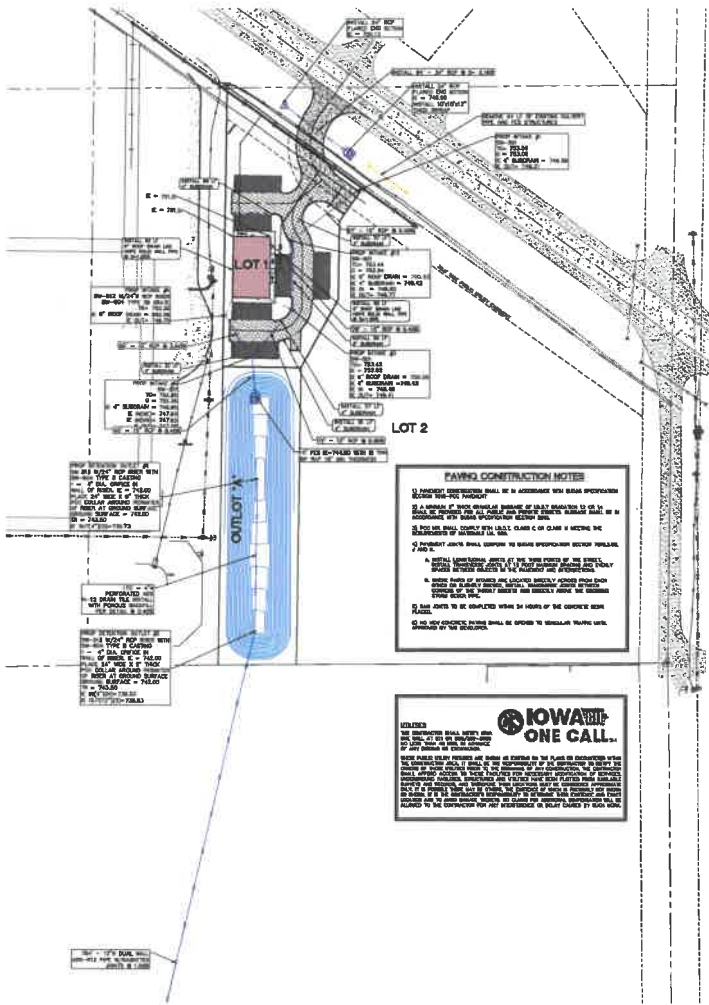

STORM SEWER AND SUB-SURFACE CONSTRUCTION NOTES

- ALL WORK SHALL BE PERFORMED IN ACCORDANCE WITH THE IOWA DEPARTMENT OF TRANSPORTATION STANDARD SPECIFICATIONS FOR ROAD AND BRIDGE CONSTRUCTION, THE IOWA DEPARTMENT OF TRANSPORTATION STANDARD SPECIFICATIONS FOR WATERWAY CONSTRUCTION, AND THE IOWA DEPARTMENT OF TRANSPORTATION STANDARD SPECIFICATIONS FOR AIRPORT CONSTRUCTION, UNLESS OTHERWISE SPECIFIED.
- ALL CONSTRUCTION SHALL BE IN ACCORDANCE WITH THE IOWA DEPARTMENT OF TRANSPORTATION STANDARD SPECIFICATIONS FOR ROAD AND BRIDGE CONSTRUCTION, THE IOWA DEPARTMENT OF TRANSPORTATION STANDARD SPECIFICATIONS FOR WATERWAY CONSTRUCTION, AND THE IOWA DEPARTMENT OF TRANSPORTATION STANDARD SPECIFICATIONS FOR AIRPORT CONSTRUCTION, UNLESS OTHERWISE SPECIFIED.
- ALL CONSTRUCTION SHALL BE IN ACCORDANCE WITH THE IOWA DEPARTMENT OF TRANSPORTATION STANDARD SPECIFICATIONS FOR ROAD AND BRIDGE CONSTRUCTION, THE IOWA DEPARTMENT OF TRANSPORTATION STANDARD SPECIFICATIONS FOR WATERWAY CONSTRUCTION, AND THE IOWA DEPARTMENT OF TRANSPORTATION STANDARD SPECIFICATIONS FOR AIRPORT CONSTRUCTION, UNLESS OTHERWISE SPECIFIED.
- ALL CONSTRUCTION SHALL BE IN ACCORDANCE WITH THE IOWA DEPARTMENT OF TRANSPORTATION STANDARD SPECIFICATIONS FOR ROAD AND BRIDGE CONSTRUCTION, THE IOWA DEPARTMENT OF TRANSPORTATION STANDARD SPECIFICATIONS FOR WATERWAY CONSTRUCTION, AND THE IOWA DEPARTMENT OF TRANSPORTATION STANDARD SPECIFICATIONS FOR AIRPORT CONSTRUCTION, UNLESS OTHERWISE SPECIFIED.
- ALL CONSTRUCTION SHALL BE IN ACCORDANCE WITH THE IOWA DEPARTMENT OF TRANSPORTATION STANDARD SPECIFICATIONS FOR ROAD AND BRIDGE CONSTRUCTION, THE IOWA DEPARTMENT OF TRANSPORTATION STANDARD SPECIFICATIONS FOR WATERWAY CONSTRUCTION, AND THE IOWA DEPARTMENT OF TRANSPORTATION STANDARD SPECIFICATIONS FOR AIRPORT CONSTRUCTION, UNLESS OTHERWISE SPECIFIED.

STANDARD LEGEND AND NOTES

Symbol	Description
[Symbol]	PROPOSED STORM SEWER
[Symbol]	EXISTING STORM SEWER
[Symbol]	PROPOSED MANHOLE
[Symbol]	EXISTING MANHOLE
[Symbol]	PROPOSED CATCH BASIN
[Symbol]	EXISTING CATCH BASIN
[Symbol]	PROPOSED CURB AND GUTTER
[Symbol]	EXISTING CURB AND GUTTER
[Symbol]	PROPOSED DRIVEWAY
[Symbol]	EXISTING DRIVEWAY
[Symbol]	PROPOSED SIDEWALK
[Symbol]	EXISTING SIDEWALK
[Symbol]	PROPOSED ASPHALT DRIVEWAY
[Symbol]	EXISTING ASPHALT DRIVEWAY
[Symbol]	PROPOSED CONCRETE DRIVEWAY
[Symbol]	EXISTING CONCRETE DRIVEWAY
[Symbol]	PROPOSED ASPHALT SIDEWALK
[Symbol]	EXISTING ASPHALT SIDEWALK
[Symbol]	PROPOSED CONCRETE SIDEWALK
[Symbol]	EXISTING CONCRETE SIDEWALK
[Symbol]	PROPOSED ASPHALT DRIVEWAY AND SIDEWALK
[Symbol]	EXISTING ASPHALT DRIVEWAY AND SIDEWALK
[Symbol]	PROPOSED CONCRETE DRIVEWAY AND SIDEWALK
[Symbol]	EXISTING CONCRETE DRIVEWAY AND SIDEWALK
[Symbol]	PROPOSED ASPHALT DRIVEWAY AND SIDEWALK WITH CURB AND GUTTER
[Symbol]	EXISTING ASPHALT DRIVEWAY AND SIDEWALK WITH CURB AND GUTTER
[Symbol]	PROPOSED CONCRETE DRIVEWAY AND SIDEWALK WITH CURB AND GUTTER
[Symbol]	EXISTING CONCRETE DRIVEWAY AND SIDEWALK WITH CURB AND GUTTER
[Symbol]	PROPOSED ASPHALT DRIVEWAY AND SIDEWALK WITH CURB AND GUTTER AND SIDEWALK
[Symbol]	EXISTING ASPHALT DRIVEWAY AND SIDEWALK WITH CURB AND GUTTER AND SIDEWALK
[Symbol]	PROPOSED CONCRETE DRIVEWAY AND SIDEWALK WITH CURB AND GUTTER AND SIDEWALK
[Symbol]	EXISTING CONCRETE DRIVEWAY AND SIDEWALK WITH CURB AND GUTTER AND SIDEWALK

CLASS "A" MANHOLE

CLASS "A" MANHOLE

STORM UTILITY PLAN AND OFFSITE STORM PLAN AND PROFILE (NORTH)

THIS PLAN SHOWS THE LOCATION OF ALL PROPOSED STORM SEWERS, MANHOLES, CATCH BASINS, AND DRIVEWAYS AND SIDEWALKS. THE PLAN SHALL BE IN ACCORDANCE WITH THE IOWA DEPARTMENT OF TRANSPORTATION STANDARD SPECIFICATIONS FOR ROAD AND BRIDGE CONSTRUCTION, THE IOWA DEPARTMENT OF TRANSPORTATION STANDARD SPECIFICATIONS FOR WATERWAY CONSTRUCTION, AND THE IOWA DEPARTMENT OF TRANSPORTATION STANDARD SPECIFICATIONS FOR AIRPORT CONSTRUCTION, UNLESS OTHERWISE SPECIFIED.

CLASS "A" MANHOLE

CLASS "A" MANHOLE

MMS CONSULTANTS, INC.

CIVIL ENGINEERS
LAND PLANNERS
LAND SURVEYORS
LANDSCAPE ARCHITECTS
ENVIRONMENTAL SPECIALISTS

1117 E. GLENN ST.
DES MOINES, IOWA 50319
(515) 281-1111
WWW.MMSCONSULTANTS.COM

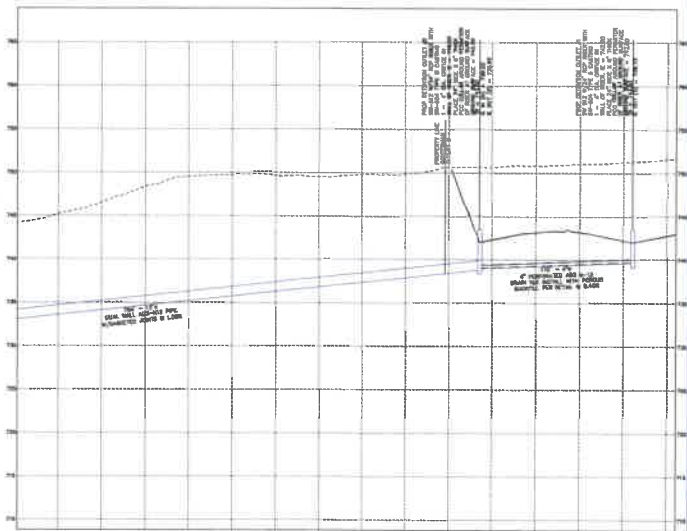

STORM UTILITY PLAN AND OFFSITE STORM PLAN AND PROFILE (NORTH)

QUICK VISIT URGENT CARE

WASHINGTON
WASHINGTON COUNTY
IOWA

MMS CONSULTANTS, INC.
07/13/2022
Project No: 11324-001
Sheet No: 138
Drawn by: JTB
Checked by: JTB
Scale: 1" = 12'-0"
Project No: 11324-001
Sheet No: C162

IOWA ONE CALL

800-368-6868

BEFORE ANY EXCAVATION OR CONSTRUCTION WORK BEGINS IN IOWA, YOU MUST CALL 800-368-6868 TO LOCATE ALL UTILITIES. CALLING ONE CALL WILL SAVE YOU TIME AND MONEY AND WILL HELP YOU AVOID ACCIDENTS AND DAMAGE TO UTILITIES. CALLING ONE CALL IS THE EASY WAY TO FIND OUT WHERE UTILITIES ARE LOCATED AND HOW DEEP THEY ARE. CALLING ONE CALL IS A REQUIREMENT OF IOWA LAW.



M&M CONSULTANTS, INC.
CIVIL ENGINEERS
LANDSCAPE ARCHITECTS
ENVIRONMENTAL SPECIALISTS
1015 E. UNIVERSITY AVENUE
DES MOINES, IOWA 50319
WWW.M&MCONSULTANTS.COM

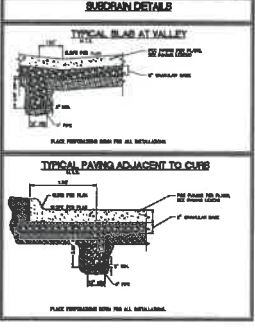
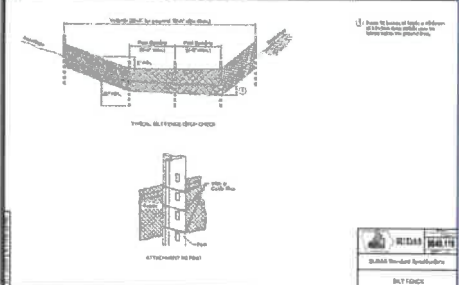
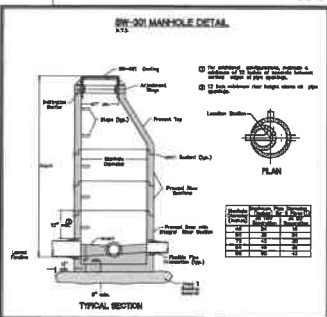
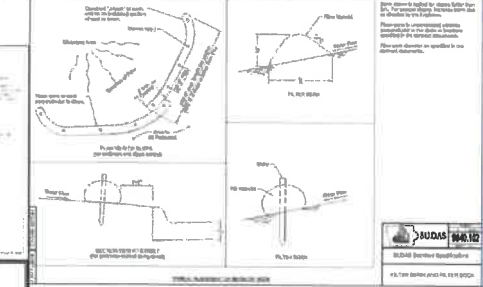
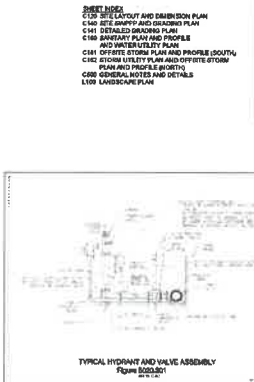
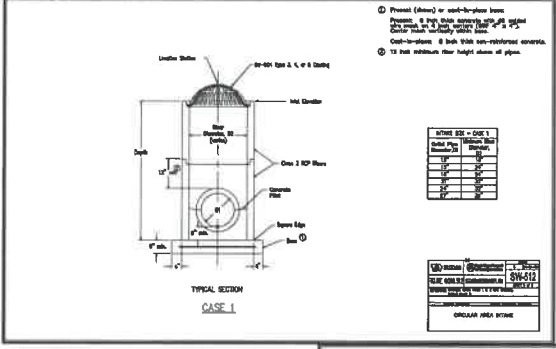
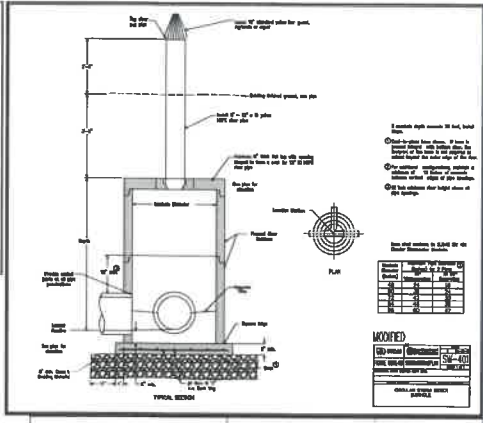
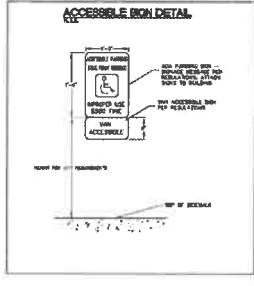
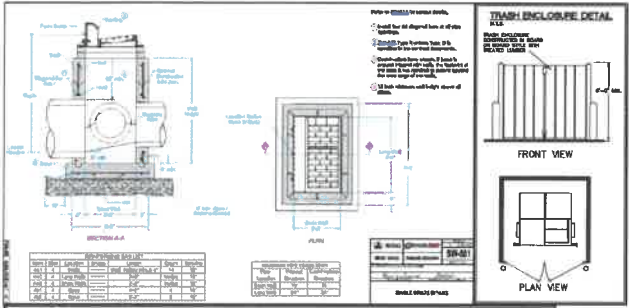

GENERAL NOTES AND DETAILS

QUICK VISIT URGENT CARE
WASHINGTON COUNTY IOWA

M&M CONSULTANTS, INC.
07/13/2022
Designed by PJA
Checked by PJA
Drawn by PJA
Scale 1/8" = 1'-0"
11324-001 C500

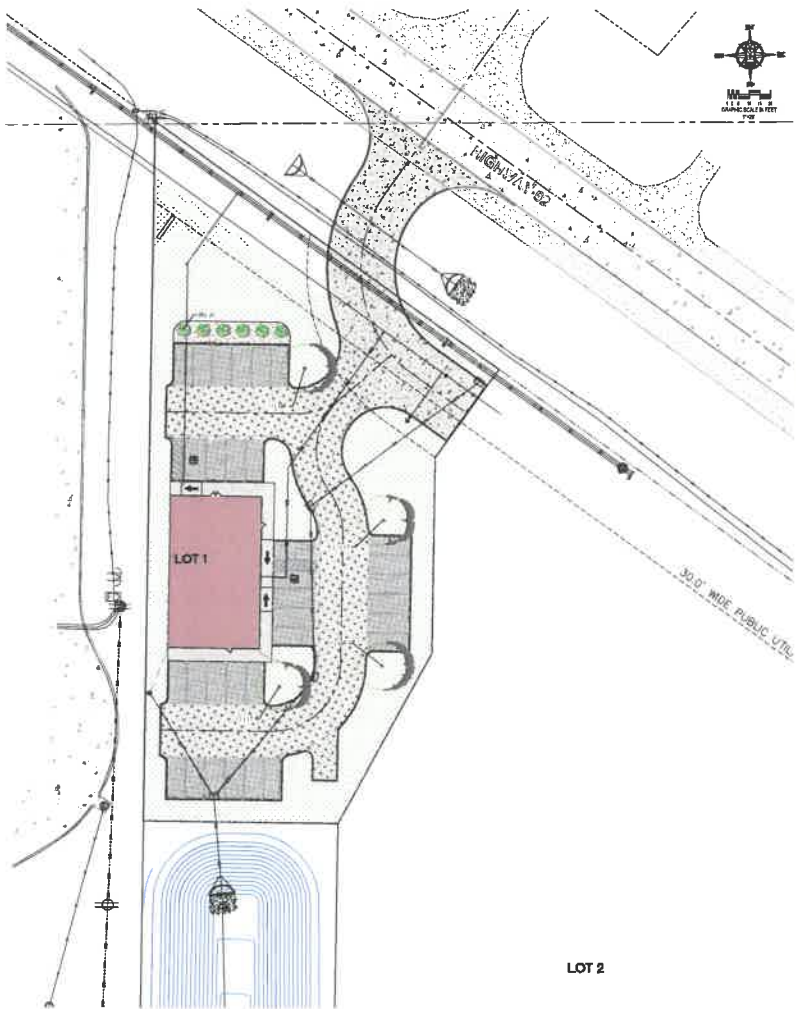

LOT 2

- SHEET INDEX
- C130 SITE LAYOUT AND DIMENSIONS PLAN
 - C140 SITE SWPPP AND GRADING PLAN
 - C150 DISTURBED GRADING PLAN
 - C160 MAINTENANCE PLAN AND PROFILE
 - C170 MAINTENANCE PLAN
 - C180 OFF-SITE STORM PLAN AND PROPOSED STORM PLAN AND PROPOSED PROTECTION
 - C190 STORM UTILITY PLAN AND PROPOSED STORM
 - C200 GENERAL NOTES AND DETAILS
 - L100 LANDSCAPE PLAN

STANDARD LEGEND AND NOTES

GENERAL NOTES	
1	PROTECT ALL EXISTING UTILITIES
2	INSTALL 4" DIA. PVC PROTECTIVE COLLAR
3	INSTALL 6" DIA. PVC PROTECTIVE COLLAR
4	INSTALL 8" DIA. PVC PROTECTIVE COLLAR
5	INSTALL 10" DIA. PVC PROTECTIVE COLLAR
6	INSTALL 12" DIA. PVC PROTECTIVE COLLAR
7	INSTALL 14" DIA. PVC PROTECTIVE COLLAR
8	INSTALL 16" DIA. PVC PROTECTIVE COLLAR
9	INSTALL 18" DIA. PVC PROTECTIVE COLLAR
10	INSTALL 20" DIA. PVC PROTECTIVE COLLAR
11	INSTALL 22" DIA. PVC PROTECTIVE COLLAR
12	INSTALL 24" DIA. PVC PROTECTIVE COLLAR
13	INSTALL 26" DIA. PVC PROTECTIVE COLLAR
14	INSTALL 28" DIA. PVC PROTECTIVE COLLAR
15	INSTALL 30" DIA. PVC PROTECTIVE COLLAR
16	INSTALL 32" DIA. PVC PROTECTIVE COLLAR
17	INSTALL 34" DIA. PVC PROTECTIVE COLLAR
18	INSTALL 36" DIA. PVC PROTECTIVE COLLAR
19	INSTALL 38" DIA. PVC PROTECTIVE COLLAR
20	INSTALL 40" DIA. PVC PROTECTIVE COLLAR

OTHER NOTES:

- MAINTAIN ALL EXISTING UTILITIES
- MAINTAIN ALL EXISTING STRUCTURES
- MAINTAIN ALL EXISTING LANDSCAPE
- MAINTAIN ALL EXISTING TREES
- MAINTAIN ALL EXISTING PLANTS
- MAINTAIN ALL EXISTING SOILS
- MAINTAIN ALL EXISTING WATER
- MAINTAIN ALL EXISTING AIR
- MAINTAIN ALL EXISTING LIGHT
- MAINTAIN ALL EXISTING SOUND
- MAINTAIN ALL EXISTING VIBRATION
- MAINTAIN ALL EXISTING QUALITY
- MAINTAIN ALL EXISTING SAFETY
- MAINTAIN ALL EXISTING SECURITY
- MAINTAIN ALL EXISTING PRIVACY
- MAINTAIN ALL EXISTING COMFORT
- MAINTAIN ALL EXISTING CONVENIENCE
- MAINTAIN ALL EXISTING ACCESSIBILITY
- MAINTAIN ALL EXISTING SUSTAINABILITY
- MAINTAIN ALL EXISTING RESILIENCE
- MAINTAIN ALL EXISTING ADAPTABILITY
- MAINTAIN ALL EXISTING FLEXIBILITY
- MAINTAIN ALL EXISTING INNOVATION
- MAINTAIN ALL EXISTING LEADERSHIP
- MAINTAIN ALL EXISTING BEST PRACTICES
- MAINTAIN ALL EXISTING STATE-OF-THE-ART
- MAINTAIN ALL EXISTING FUTURE-PROOFING
- MAINTAIN ALL EXISTING RISK-MITIGATION
- MAINTAIN ALL EXISTING OPPORTUNITY

LANDSCAPE LEGEND

SYMBOLS AND DIMENSIONS

LANDSCAPE REQUIREMENTS

- 1. TREE PER 100 SQ FT OF LOT AREA
- 2. TREE PER 100 SQ FT OF LOT AREA
- 3. TREE PER 100 SQ FT OF LOT AREA
- 4. TREE PER 100 SQ FT OF LOT AREA
- 5. TREE PER 100 SQ FT OF LOT AREA
- 6. TREE PER 100 SQ FT OF LOT AREA
- 7. TREE PER 100 SQ FT OF LOT AREA
- 8. TREE PER 100 SQ FT OF LOT AREA
- 9. TREE PER 100 SQ FT OF LOT AREA
- 10. TREE PER 100 SQ FT OF LOT AREA
- 11. TREE PER 100 SQ FT OF LOT AREA
- 12. TREE PER 100 SQ FT OF LOT AREA
- 13. TREE PER 100 SQ FT OF LOT AREA
- 14. TREE PER 100 SQ FT OF LOT AREA
- 15. TREE PER 100 SQ FT OF LOT AREA
- 16. TREE PER 100 SQ FT OF LOT AREA
- 17. TREE PER 100 SQ FT OF LOT AREA
- 18. TREE PER 100 SQ FT OF LOT AREA
- 19. TREE PER 100 SQ FT OF LOT AREA
- 20. TREE PER 100 SQ FT OF LOT AREA

PLANT SCHEDULE

NO.	SYM	NAME	PLANT	SIZE	QUANTITY	NOTES
1	TR1	ORNAMENTAL TREE	ORNAMENTAL TREE	10" DBH	10	SEE SCHEDULE FOR DETAILS
2	TR2	ORNAMENTAL TREE	ORNAMENTAL TREE	12" DBH	10	SEE SCHEDULE FOR DETAILS
3	TR3	ORNAMENTAL TREE	ORNAMENTAL TREE	14" DBH	10	SEE SCHEDULE FOR DETAILS
4	TR4	ORNAMENTAL TREE	ORNAMENTAL TREE	16" DBH	10	SEE SCHEDULE FOR DETAILS
5	TR5	ORNAMENTAL TREE	ORNAMENTAL TREE	18" DBH	10	SEE SCHEDULE FOR DETAILS
6	TR6	ORNAMENTAL TREE	ORNAMENTAL TREE	20" DBH	10	SEE SCHEDULE FOR DETAILS
7	TR7	ORNAMENTAL TREE	ORNAMENTAL TREE	22" DBH	10	SEE SCHEDULE FOR DETAILS
8	TR8	ORNAMENTAL TREE	ORNAMENTAL TREE	24" DBH	10	SEE SCHEDULE FOR DETAILS
9	TR9	ORNAMENTAL TREE	ORNAMENTAL TREE	26" DBH	10	SEE SCHEDULE FOR DETAILS
10	TR10	ORNAMENTAL TREE	ORNAMENTAL TREE	28" DBH	10	SEE SCHEDULE FOR DETAILS
11	TR11	ORNAMENTAL TREE	ORNAMENTAL TREE	30" DBH	10	SEE SCHEDULE FOR DETAILS
12	TR12	ORNAMENTAL TREE	ORNAMENTAL TREE	32" DBH	10	SEE SCHEDULE FOR DETAILS
13	TR13	ORNAMENTAL TREE	ORNAMENTAL TREE	34" DBH	10	SEE SCHEDULE FOR DETAILS
14	TR14	ORNAMENTAL TREE	ORNAMENTAL TREE	36" DBH	10	SEE SCHEDULE FOR DETAILS
15	TR15	ORNAMENTAL TREE	ORNAMENTAL TREE	38" DBH	10	SEE SCHEDULE FOR DETAILS
16	TR16	ORNAMENTAL TREE	ORNAMENTAL TREE	40" DBH	10	SEE SCHEDULE FOR DETAILS
17	TR17	ORNAMENTAL TREE	ORNAMENTAL TREE	42" DBH	10	SEE SCHEDULE FOR DETAILS
18	TR18	ORNAMENTAL TREE	ORNAMENTAL TREE	44" DBH	10	SEE SCHEDULE FOR DETAILS
19	TR19	ORNAMENTAL TREE	ORNAMENTAL TREE	46" DBH	10	SEE SCHEDULE FOR DETAILS
20	TR20	ORNAMENTAL TREE	ORNAMENTAL TREE	48" DBH	10	SEE SCHEDULE FOR DETAILS

IOWA ONE CALL
800-855-8373

DATE: 07/13/2022
DRAWN BY: [Name]

- LANDSCAPE NOTES
1. ALL DISTURBED AREAS SHALL BE REVEGETATED WITH ORIGINAL PLANTING OR EQUIVALENT.
 2. MAINTAIN ALL EXISTING UTILITIES AND STRUCTURES.
 3. MAINTAIN ALL EXISTING LANDSCAPE AND PLANTING.
 4. MAINTAIN ALL EXISTING TREES AND PLANTS.
 5. MAINTAIN ALL EXISTING SOILS.
 6. MAINTAIN ALL EXISTING WATER.
 7. MAINTAIN ALL EXISTING AIR.
 8. MAINTAIN ALL EXISTING LIGHT.
 9. MAINTAIN ALL EXISTING SOUND.
 10. MAINTAIN ALL EXISTING VIBRATION.
 11. MAINTAIN ALL EXISTING QUALITY.
 12. MAINTAIN ALL EXISTING SAFETY.
 13. MAINTAIN ALL EXISTING SECURITY.
 14. MAINTAIN ALL EXISTING PRIVACY.
 15. MAINTAIN ALL EXISTING COMFORT.
 16. MAINTAIN ALL EXISTING CONVENIENCE.
 17. MAINTAIN ALL EXISTING ACCESSIBILITY.
 18. MAINTAIN ALL EXISTING SUSTAINABILITY.
 19. MAINTAIN ALL EXISTING RESILIENCE.
 20. MAINTAIN ALL EXISTING ADAPTABILITY.
 21. MAINTAIN ALL EXISTING FLEXIBILITY.
 22. MAINTAIN ALL EXISTING INNOVATION.
 23. MAINTAIN ALL EXISTING LEADERSHIP.
 24. MAINTAIN ALL EXISTING BEST PRACTICES.
 25. MAINTAIN ALL EXISTING STATE-OF-THE-ART.
 26. MAINTAIN ALL EXISTING FUTURE-PROOFING.
 27. MAINTAIN ALL EXISTING RISK-MITIGATION.
 28. MAINTAIN ALL EXISTING OPPORTUNITY.

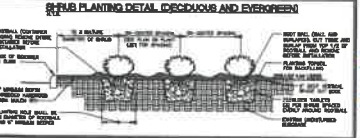
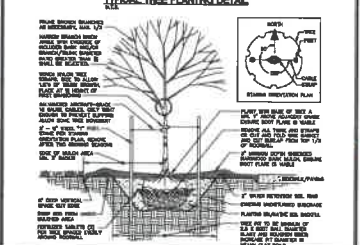

MMS CONSULTANTS, INC.
1315 E. 15TH ST., SUITE 100
DES MOINES, IA 50319
515.278.1111
WWW.MMSCONSULTANTS.COM

IOWA ONE CALL
800-855-8373

LANDSCAPE PLAN

QUICK VISIT URGENT CARE
WASHINGTON WASHINGTON COUNTY IOWA

MMS CONSULTANTS, INC.
07/13/2022
Drawn by: [Name]
Checked by: [Name]
11324-001 L100

Copy

Prepared by: Richard S. Bordwell, Bordwell Law Office, P.L.C., 206 W. Main, Washington, IA 52353, 319-653-2177
Return to: Richard S. Bordwell, Bordwell Law Office, P.L.C., 206 W. Main, Washington, IA 52353

STORM WATER DRAINAGE AND CONSTRUCTION EASEMENT AGREEMENT

This Storm Water Drainage and Construction Easement Agreement (this "Easement") is made as of this 20th day of July, 2022, by and **Vickie L. Gonterman**, a single person, ("Grantors"), and **J. Gregory Wiley and Lori Wiley**, husband and wife ("Grantee").

PRELIMINARY STATEMENTS

Grantors are the fee simple owner of certain real property legally described in Exhibit A attached hereto. Grantee is the fee simple owner of the real property legally described in Exhibit B attached hereto (collectively the "Wiley Property"). Grantors hereby acknowledge that some rain/storm water falling on the Wiley Property currently drains onto the Easement Area. Grantors further acknowledge that Grantee intends to develop their property for commercial purposes and that such storm water shall continue to drain from the Wiley Property onto the Easement Area. Subject to the terms and conditions set forth herein, Grantors desire to grant to Grantee and their successors and assigns, for the benefit of the Wiley Property, a nonexclusive, perpetual thirty (30) foot wide drainage and construction easement (the "Easement Area") to allow the construction of a drain pipe which will allow rain/storm water falling on the Wiley Property to enter a holding pond on the Wiley Property, which will be released into the pipes in the Easement Area so that the excess water will be discharged into the stream as shown on Exhibit A-1.

AGREEMENT

For and in consideration of \$5,000.00 paid to Vickie L. Gonterman and other good and valuable consideration, the receipt and sufficiency of which is hereby acknowledged, the parties hereby agree as follows:

1. Grant of Permanent Drainage Easement. Subject to any restrictions, easements or other matters of record or otherwise set forth herein, Grantors hereby grant to Grantee and their successors and assigns, for the benefit of the Wiley Property, a nonexclusive, perpetual drainage easement to allow storm water leaving the Wiley Property to enter onto, and under, the Easement Area. The easement shall be ten (10) feet wide centered on the drainage pipe as constructed plus an additional twenty (20) feet wide construction, repair and reconstruction easement along the length of the drainage pipes.

2. Grant of Construction Easement. Subject to any restrictions, easements or other matters of record or otherwise set forth herein, Grantors hereby grant to Grantee and their successors and assigns, for the benefit of the Wiley Property, a nonexclusive, perpetual easement to allow the construction, installation, repair and maintenance of a 12 inch diameter drain tile line within the Easement Area. The drain line shall have cover of not less than four (4) feet of soil with topsoil restored to original condition. The initial drainage pipes shall be installed after the 2022 crops have been removed from Grantor's land.

Grantee, their heirs, successors and assigns, shall be responsible for all costs and expenses relating to the construction, installation, repair and maintenance of said tile line and shall indemnify and hold harmless Grantors from any cost or expense relating thereto. Grantee shall also be responsible for and reimburse Grantors for any crop loss in the construction, installation, repair and maintenance of said tile line. In the event of a tile "blow out" Grantee

shall repair the tile not later than ten (10) days after being notified by Grantors and shall be responsible for any damage caused by the "blow out".

Following construction and/or repair, Grantee shall be responsible for restoring the Easement Area to a condition reasonably similar to its original condition. Top soil shall be set aside and reapplied as top soil. Waterways shall be reshaped and reseeded.

3. Use; Improvements. Grantee, their heirs, successors and assigns, acknowledges Grantors' right to use, landscape, cultivate and otherwise enjoy the Easement Area, provided that Grantors agree not to build, create or construct or permit to be built, created, or constructed any building or other obstruction that would unreasonably interfere with the Easement Area, the drainage tile within the Easement Area and Grantee's rights hereunder. Notwithstanding the foregoing, Grantors shall have the right at its sole cost and expense to relocate the Easement Area upon Grantors' property, provided Grantors shall provide drainage pipe in equal or better condition to that in the Easement Area and in no event adversely affect the flow of storm water leaving the Wiley Property.

4. Binding Upon Property and Parties. Upon the filing of this agreement with the Washington County Recorder's Office, the easements, rights and obligations created pursuant to this Easement shall be appurtenant to and run with and be binding upon the real properties herein identified, including future subdivisions and/or reconfigurations of such properties, and shall be binding on all entities having or acquiring any right, title or interest in such properties and shall inure to the benefit of each owner, tenant, subtenant, employee or invitee thereof. This Easement shall inure to the benefit of and bind the parties hereto and their respective executors, heirs, administrators, successors and assigns.

5. Non-Merger. The easements, rights and obligations established by this Easement shall not merge or terminate if all of the Easement Area and the Wiley Property become owned by the same entity, but shall continue until released and terminated by all parties benefited hereby.

6. No Dedication. Nothing herein contained shall be deemed to be a gift or dedication of any portion of the Easement Area to the general public, or for any public use, or purpose whatsoever. Except as herein specifically provided, no rights, privileges or immunities of any party hereto shall inure to the benefit of any third party, nor shall any third party be deemed to be a beneficiary of any of the provisions contained in this Easement.

7. Title. Grantors confirm with Grantee that Grantors are seized in fee and is the sole holder of the Easement Area and that it has the right to grant and convey this Easement and the rights granted herein, and that it will warrant and defend such Easement and rights to Grantee against the lawful claims and demands of all persons.

8. No Agency or Partnership. This Agreement is not intended and shall not be construed to create the relationship of agent, servant, employee, partnership, joint venture or association as between Grantors or Grantee nor between or among Grantors, Grantee and any officer, employee, contractor or representative of such party. No joint employment is intended or created by this Agreement for any purpose. Each party hereby agrees to so inform its employees, agents, contractors and subcontractors who are involved in the implementation of this Agreement.

9. Further Consideration. Grantors, along with their successor and assigns, as further consideration, reserve the right to hook onto the 12 inch tile line at any time in the future so long as it does not have a negative effect on the operation of this tile line. Such connection shall not be made without first notifying Grantee, their heirs, successors and assigns, in writing of the proposed connection. As additional consideration, Grantee further agrees to require the contractor installing the drainage pipe to record the GPS location wherever the Grantor tile lines are broken and Grantee will provide Grantor with a copy of the as-built drainage map showing the locations where farm drainage tiles were cut, along with the GPS coordinates.

10. The parties to this Agreement acknowledge that this easement is a necessary part of the process for the creation of WILEY SUBDIVISION, THIRD ADDITION, WASHINGTON, IOWA, and as a part of that process, the parties understand that J. Gregory Wiley and Lori Wiley, husband and wife, will be assigning all of their interests, and obligations, in this Agreement to an Owner's Association, to be created as a corporation not for profit, the members of which shall be all of the lot owners of said subdivision. The Owners Association shall then be responsible for the pipeline operation, maintenance and any reconstruction or improvements after the initial construction is completed by or under the direction of Palm Development Partners.

Signed this 20th day of July, 2022.

GRANTORS OF EASEMENT:

Vickie L. Gonterm copy
Vickie L. Gonterm

GRANTEES OF EASEMENT:

J. Gregory Wiley
J. Gregory Wiley
Lori Wiley
Lori Wiley

STATE OF IOWA, COUNTY OF WASHINGTON, ss:

This instrument was acknowledged before me on this 20th day of July, 2022, by: Vickie L. Gonterm.

Richard S. Bordwell
Notary Public



STATE OF IOWA, COUNTY OF WASHINGTON, ss:

This instrument was acknowledged before me on this 22nd day of July, 2022, by: J. Gregory Wiley and Lori Wiley.

Richard S. Bordwell
Notary Public

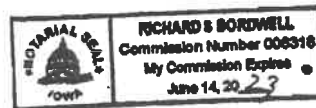

I:\z\7200\7205\7205 Storm Water Drainage and Construction Easement Agr Gonterm\220707\2024

EXHIBIT A

GONTERMAN REAL ESTATE:

The center line of the "Easement Area" shall be approximately as shown on the map "Exhibit A-1". The Grantors reserve the right to determine the exact location of the water drainage line over the following property:

The Northeast Quarter (NE $\frac{1}{4}$) of the Northeast Quarter (NE $\frac{1}{4}$) of Section number twenty-one (21), in Township number seventy-five (75) North, of Range number Seven (7) West of the Fifth (5th) Principal Meridian; EXCEPTING therefrom one square acre in the northeast corner of said NE $\frac{1}{4}$ of NE $\frac{1}{4}$; and ALSO EXCEPTING therefrom a tract commencing at the southeast corner of said NE $\frac{1}{4}$ of NE $\frac{1}{4}$, running thence West along the South line of said NE $\frac{1}{4}$ of the NE $\frac{1}{4}$, 285 feet; thence North parallel to the East line of said Section 21, 305 feet 4 inches; thence East parallel to the South line of said Quarter Section, 285 feet to the East line of said Section 21; thence South along the Section line 305 feet 4 inches to the place of beginning; in Washington County, Iowa.

EXHIBIT B

J. GREGORY AND LORI WILEY REAL ESTATE

Auditor's Parcel V, containing 5.71 acres, in the Southeast Quarter (SE $\frac{1}{4}$) of the Southeast Quarter (SE $\frac{1}{4}$) of Section Sixteen (16), Township Seventy-five (75) North, Range Seven (7) West of the Fifth (5th) Principal Meridian, in the City of Washington, as shown in Plat Book 31, Page 28; in Washington County, Iowa.

EXHIBIT "A-1"

STORM WATER DRAINAGE AND CONSTRUCTION EXHIBIT

WASHINGTON COUNTY, IOWA

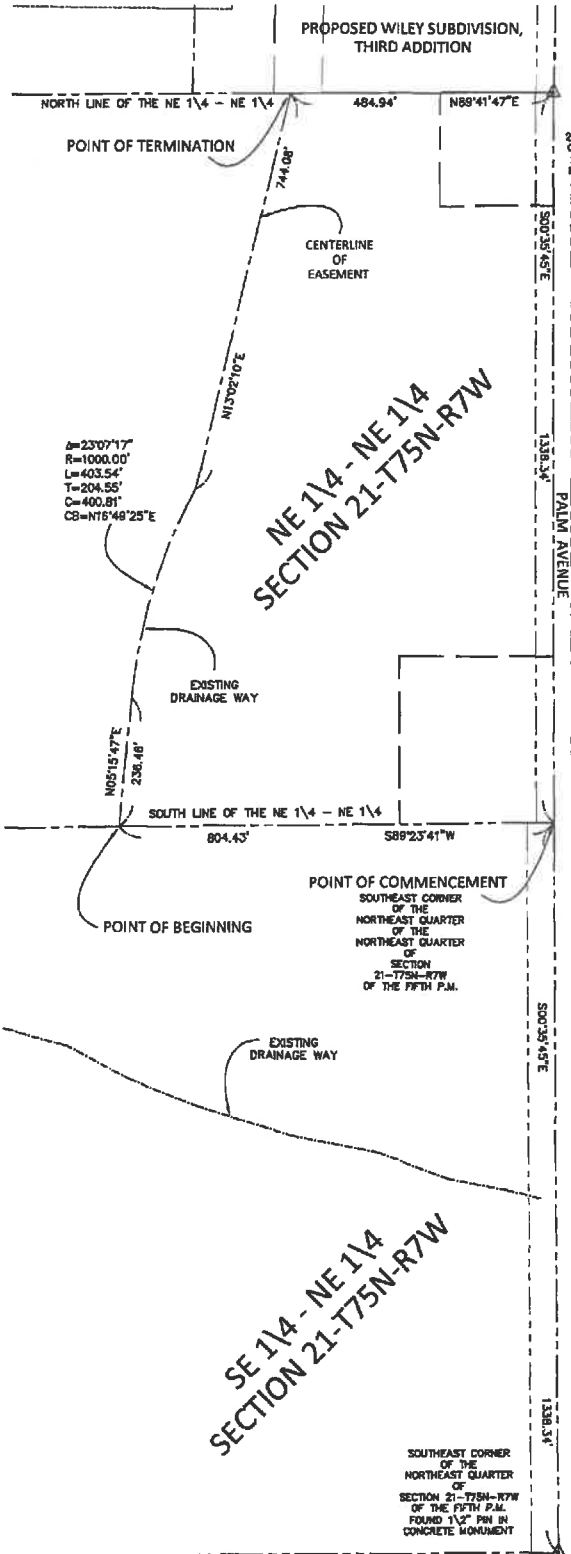

LEGEND AND NOTES	
	CONGRESSIONAL CORNER, FOUND
	PROPERTY &/or BOUNDARY LINES
	CONGRESSIONAL SECTION LINES
	RIGHT-OF-WAY LINES
	CENTER LINES
	LOT LINES, PLATTED OR BY DEED
	EASEMENT LINES, WIDTH & PURPOSE NOTED
	EXISTING EASEMENT LINES, PURPOSE NOTED
	RECORDED DIMENSIONS
	MEASURED DIMENSIONS

UNLESS NOTED OTHERWISE, ALL DIMENSIONS ARE IN FEET AND HUNDRETHS

LOCATION:	PROPRIETOR OR OWNER:
A PORTION OF THE NORTHEAST QUARTER OF THE NORTHEAST QUARTER OF SECTION 21, TOWNSHIP 75 NORTH, RANGE 7 WEST, OF THE FIFTH PRINCIPAL MERIDIAN, WASHINGTON COUNTY, IOWA.	GONTERMAN, MCKIE L. 2505 PALM AVE WASHINGTON IA 52333

DESCRIPTION - EASEMENT CENTERLINE

Commencing at the Southeast Corner of the Northeast Quarter of the Northeast Quarter of Section 21, Township 75 North, Range 7 West, of the Fifth Principal Meridian, Washington County, Iowa; Thence S89°23'41"W, along the South Line of said Northeast Quarter of the Northeast Quarter, 804.43 feet, to the POINT OF BEGINNING; Thence N05°15'47"E, 236.46 feet; Thence Northeasterly, 403.54 feet, along a 1000.00 foot radius curve, concave Southeasterly, whose 400.81 foot chord bears N16°49'25"E; Thence N13°02'10"E, 744.08 feet, to a Point on the North Line of said Northeast Quarter of the Northeast Quarter, and the Point of Termination.

SEAL

I hereby certify that this land surveying document was prepared and the related survey work performed by me or under my direct supervision and that I am a duly licensed Professional Land Surveyor under the laws of the State of Iowa.

7.20.22

Richard R. Moncton
P.L.S. Iowa Lic. No. 17816
My license renewal date is December 31, 2023

Pages or sheets covered by this seal: 1

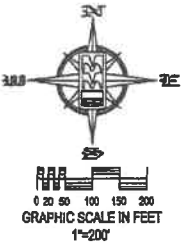

Date	Revision
07-20-2022	PER PVA CLIENT - RLW
07-20-2022	PER RIN REVIEW - RLW

EASEMENT EXHIBIT

WASHINGTON COUNTY
IOWA

MMS CONSULTANTS, INC.

Date: 07-13-2022
Designed by: PVA
Drawn by: RLW
Checked by: RSN
Project No.: IC-11324-001
Sheet No.: 1 of 1

CIVIL ENGINEERS
LAND PLANNERS
LAND SURVEYORS
LANDSCAPE ARCHITECTS
ENVIRONMENTAL SPECIALISTS

1917 S. GILBERT ST.
IOWA CITY, IOWA 52240
(319) 351-8282
www.mmsconsultantsinc.net

copy

Prepared by: Richard S. Bordwell, Bordwell Law Office, P.L.C., 206 W. Main, Washington, IA 52353, 319-653-2177
Return to: Richard S. Bordwell, Bordwell Law Office, P.L.C., 206 W. Main, Washington, IA 52353

STORM WATER DRAINAGE AND CONSTRUCTION EASEMENT AGREEMENT

This Storm Water Drainage and Construction Easement Agreement (this "Easement") is made as of this 21st day of July, 2022, by and between **Wilfrid J. Vittetoe**, a single person, **Wilfrid J. Vittetoe**, as Executor of the Estate of **Clarabell Vittetoe, Jerome Vittetoe and Heidi Vittetoe**, husband and wife, individually and **J&H Legacy Farms, LLC** (collectively "Grantors"), and **J. Gregory Wiley and Lori Wiley**, husband and wife ("Grantee").

PRELIMINARY STATEMENTS

Grantors are the fee simple owner of certain real property legally described in Exhibit A attached hereto. Grantee is the fee simple owner of the real property legally described in Exhibit B attached hereto (collectively the "Wiley Property"). Grantors hereby acknowledge that some rain/storm water falling on the Wiley Property currently drains onto the Easement Area. Grantors further acknowledge that Grantee intends to develop their property for commercial purposes and that such storm water shall continue to drain from the Wiley Property onto the Easement Area. Subject to the terms and conditions set forth herein, Grantors desire to grant to Grantee and their successors and assigns, for the benefit of the Wiley Property, a nonexclusive, perpetual thirty (30) foot wide drainage and construction easement (the "Easement Area") to allow the construction of a drain pipe which will allow rain/storm water falling on the Wiley Property to enter a holding pond on the Wiley Property, which will be released into the pipes in the Easement Area so that the excess water will be discharged into the stream as shown on Exhibit A-1.

AGREEMENT

For and in consideration of \$1,000.00 paid \$500.00 to Wilfrid Vittetoe and \$500.00 to J&H Legacy Farms, LLC and other good and valuable consideration, the receipt and sufficiency of which is hereby acknowledged, the parties hereby agree as follows:

1. **Grant of Permanent Drainage Easement.** Subject to any restrictions, easements or other matters of record or otherwise set forth herein, Grantors hereby grant to Grantee and their successors and assigns, for the benefit of the Wiley Property, a nonexclusive, perpetual drainage easement to allow storm water leaving the Wiley Property to enter onto, and under, the Easement Area. The easement shall be ten (10) feet wide centered on the drainage pipe as constructed plus an additional twenty (20) feet wide construction, repair and reconstruction easement along the length of the drainage pipes.

2. **Grant of Construction Easement.** Subject to any restrictions, easements or other matters of record or otherwise set forth herein, Grantors hereby grant to Grantee and their successors and assigns, for the benefit of the Wiley Property, a nonexclusive, perpetual easement to allow the construction, installation, repair and maintenance of a 12 inch diameter drain tile line within the Easement Area. The drain line shall have cover of not less than four (4) feet of soil with topsoil restored to original condition. The initial drainage pipes shall be installed after the 2022 crops have been removed from Grantor's land.

Grantee, their heirs, successors and assigns, shall be responsible for all costs and expenses relating to the construction, installation, repair and maintenance of said tile line and shall indemnify and hold harmless Grantors from any cost or expense relating thereto. Grantee

shall also be responsible for and reimburse Grantors for any crop loss in the construction, installation, repair and maintenance of said tile line. In the event of a tile "blow out" Grantee shall repair the tile not later than ten (10) days after being notified by Grantors and shall be responsible for any damage caused by the "blow out".

Following construction and/or repair, Grantee shall be responsible for restoring the Easement Area to a condition reasonably similar to its original condition. Top soil shall be set aside and reapplied as top soil. Waterways shall be reshaped and reseeded.

3. Use; Improvements. Grantee, their heirs, successors and assigns, acknowledges Grantors' right to use, landscape, cultivate and otherwise enjoy the Easement Area, provided that Grantors agree not to build, create or construct or permit to be built, created, or constructed any building or other obstruction that would unreasonably interfere with the Easement Area, the drainage tile within the Easement Area and Grantee's rights hereunder. Notwithstanding the foregoing, Grantors shall have the right at its sole cost and expense to relocate the Easement Area upon Grantors' property, provided Grantors shall provide drainage pipe in equal or better condition to that in the Easement Area and in no event adversely affect the flow of storm water leaving the Wiley Property.

4. Binding Upon Property and Parties. Upon the filing of this agreement with the Washington County Recorder's Office, the easements, rights and obligations created pursuant to this Easement shall be appurtenant to and run with and be binding upon the real properties herein identified, including future subdivisions and/or reconfigurations of such properties, and shall be binding on all entities having or acquiring any right, title or interest in such properties and shall inure to the benefit of each owner, tenant, subtenant, employee or invitee thereof. This Easement shall inure to the benefit of and bind the parties hereto and their respective executors, heirs, administrators, successors and assigns.

5. Non-Merger. The easements, rights and obligations established by this Easement shall not merge or terminate if all of the Easement Area and the Wiley Property become owned by the same entity, but shall continue until released and terminated by all parties benefited hereby.

6. No Dedication. Nothing herein contained shall be deemed to be a gift or dedication of any portion of the Easement Area to the general public, or for any public use, or purpose whatsoever. Except as herein specifically provided, no rights, privileges or immunities of any party hereto shall inure to the benefit of any third party, nor shall any third party be deemed to be a beneficiary of any of the provisions contained in this Easement.

7. Title. Grantors confirm with Grantee that Grantors are seized in fee and is the sole holder of the Easement Area and that it has the right to grant and convey this Easement and the rights granted herein, and that it will warrant and defend such Easement and rights to Grantee against the lawful claims and demands of all persons.

8. No Agency or Partnership. This Agreement is not intended and shall not be construed to create the relationship of agent, servant, employee, partnership, joint venture or association as between Grantors or Grantee nor between or among Grantors, Grantee and any officer, employee, contractor or representative of such party. No joint employment is intended or created by this Agreement for any purpose. Each party hereby agrees to so inform its employees, agents, contractors and subcontractors who are involved in the implementation of this Agreement.

9. Further Consideration. Grantors, along with their successor and assigns, as further consideration, reserve the right to hook onto the 12 inch tile line at any time in the future so long as it does not have a negative effect on the operation of this tile line. Such connection shall not be made without first notifying Grantee, their heirs, successors and assigns, in writing of the proposed connection. As additional consideration, Grantee further agrees to require the contractor installing the drainage pipe to record the GPS location wherever the Grantor tile lines are broken and Grantee will provide Grantor with a copy of the as-built drainage map showing the locations where farm drainage tiles were cut, along with the GPS coordinates.

10. The parties to this Agreement acknowledge that this easement is a necessary part of the process for the creation of WILEY SUBDIVISION, THIRD ADDITION, WASHINGTON, IOWA, and as a part of that process, the parties understand that J. Gregory Wiley and Lori Wiley, husband and wife, will be assigning all of their interests, and obligations, in this Agreement to an Owner's Association, to be created as a corporation not for profit, the members of which shall be all of the lot owners of said subdivision. The Owners Association shall then be responsible for the pipeline operation, maintenance and any reconstruction or improvements after the initial construction is completed by or under the direction of Palm Development Partners.

Signed this 21st day of July, 2022.

GRANTORS OF EASEMENT

GRANTEES OF EASEMENT

Wilfrid J. Vittetoe
 Wilfrid J. Vittetoe, single

+ J. Gregory Wiley
 J. Gregory Wiley

Wilfrid J. Vittetoe
 Wilfrid J. Vittetoe, of
 Clerk

+ Lori Wiley
 Lori Wiley

Jerome Vittetoe
 Jerome Vittetoe

Heidi Vittetoe
 Heidi Vittetoe

J&H LEGACY, LLC by:

Jerome Vittetoe
 Jerome Vittetoe, Manager

STATE OF IOWA, COUNTY OF WASHINGTON, ss:

This instrument was acknowledged before me on this 21st day of July, 2022, by:
 Wilfrid J. Vittetoe.

Lisa D. Kempf
 Notary Public



STATE OF IOWA, COUNTY OF WASHINGTON, ss:

This instrument was acknowledged before me on this 21st day of July, 2022, by:
 Wilfrid J. Vittetoe as Executor of the Estate of Clarabell Vittetoe.

Lisa D. Kempf
 Notary Public

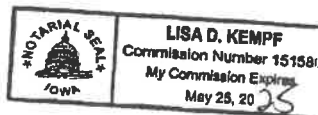

STATE OF IOWA, COUNTY OF WASHINGTON, ss:

This instrument was acknowledged before me on this 21st day of July, 2022, by:
Jerome W. Vittetoe and Heidi Vittetoe.

[Signature]
_____, Notary Public



STATE OF IOWA, COUNTY OF WASHINGTON, ss:

This instrument was acknowledged before me on this 21st day of July, 2022, by:
Jerome Vittetoe as Manager of J&H Legacy Farms, LLC.

[Signature]
_____, Notary Public



STATE OF IOWA, COUNTY OF WASHINGTON, ss:

This instrument was acknowledged before me on this 22nd day of July, 2022, by: J.
Gregory Wiley and Lori Wiley.

[Signature]
_____, Notary Public



I:\a\7200\7205\7205 Storm Water Drainage and Construction Easement Agr Vittetoe\220707\20

EXHIBIT A

VITTETOE REAL ESTATE:

The center line of the "Easement Area" shall be approximately as shown on the map "Exhibit A-1". The Grantors reserve the right to determine the exact location of the water drainage line over the following property:

The South Half (S½) of the Northeast Quarter (NE¼) of Section number Twenty-one (21), in Township number Seventy-Five (75) North, of Range number Seven (7) West of the fifth (5th) Principal Meridian; excepting therefrom the following: beginning at a point in the middle of the public highway, 530.8 feet north of the center of Section number Twenty-one (21), in Township number Seventy-Five (75) North, of Range number Seven (7) West of the Fifth (5th) Principal Meridian, thence east 250 feet, thence north 280 feet, thence west 250 feet, thence south 280 feet to the point of beginning; in Washington County, Iowa. ALSO EXCEPTING: Commencing at the S.W. corner of the NE¼, Sec. 21, T-75N, R-7W of the 5th P.M., Washington County, Iowa, thence N 261.36', thence E 250.00', thence S 261.36', thence W 250.00' to the point of beginning.

EXHIBIT B

J. GREGORY AND LORI WILEY REAL ESTATE:

Auditor's Parcel V, containing 5.71 acres, in the Southeast Quarter (SE¼) of the Southeast Quarter (SE¼) of Section Sixteen (16), Township Seventy-five (75) North, Range Seven (7) West of the Fifth (5th) Principal Meridian, in the City of Washington, as shown in Plat Book 31, Page 28; in Washington County, Iowa.

EXHIBIT "A-1"

STORM WATER DRAINAGE AND CONSTRUCTION EXHIBIT

WASHINGTON COUNTY, IOWA

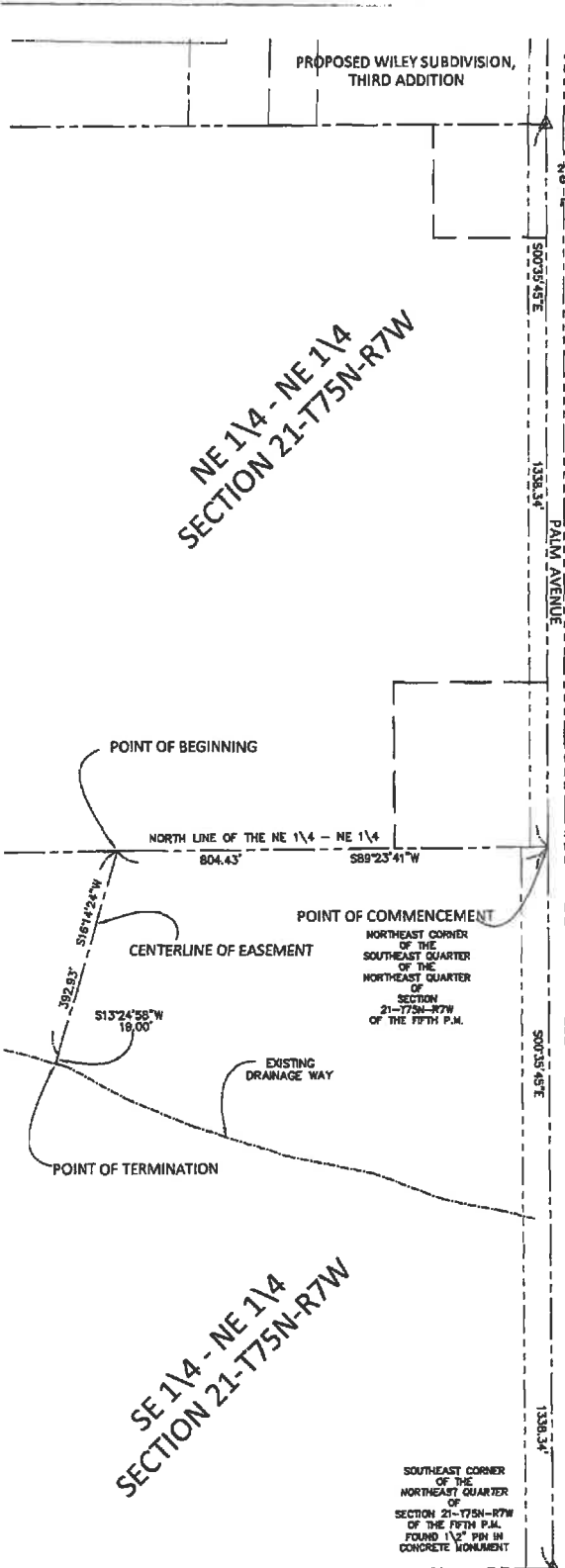

LEGEND AND NOTES	
Δ	CONGRESSIONAL CORNER, FOUND PROPERTY &/or BOUNDARY LINES
---	CONGRESSIONAL SECTION LINES
- - -	RIGHT-OF-WAY LINES
---	CENTER LINES
- - -	LOT LINES, PLATTED OR BY DEED
- - -	EASEMENT LINES, WIDTH & PURPOSE NOTED
- - -	EXISTING EASEMENT LINES, PURPOSE NOTED
(R)	RECORDED DIMENSIONS
(M)	MEASURED DIMENSIONS
UNLESS NOTED OTHERWISE, ALL DIMENSIONS ARE IN FEET AND HUNDREDTHS	

LOCATION:	PROPRIETOR OR OWNER:
A PORTION OF THE SOUTHEAST QUARTER OF THE NORTHEAST QUARTER OF SECTION 21, TOWNSHIP 75 NORTH, RANGE 7 WEST, OF THE FIFTH PRINCIPAL MERIDIAN, WASHINGTON COUNTY, IOWA.	DEED HOLDER CLARABELL M. VITTECCE
	CONTRACT HOLDER J & H LEGACY FARMS, LLC, ET AL 2504 QUINCE AVE WASHINGTON IA 52353

DESCRIPTION - EASEMENT CENTERLINE

Commencing at the Northeast Corner of the Southeast Quarter of the Northeast Quarter of Section 21, Township 75 North, Range 7 West, of the Fifth Principal Meridian, Washington County, Iowa; Thence 589°23'41"W, along the North Line of said Southeast Quarter of the Northeast Quarter, 804.43 feet, to the POINT OF BEGINNING; Thence 516°14'24"W, 392.93 feet; Thence 513°24'58"W, 19.00 feet, to the Point of Termination.

I hereby certify that this land surveying document was prepared and the related survey work was performed by me or under my direct supervision and that I am a duly Licensed Professional Land Surveyor under the laws of the State of Iowa.

7-21-2022

Pages or sheets covered by this seal: 1

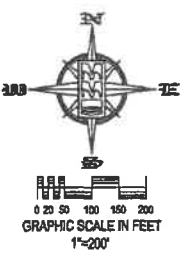

WASHINGTON COUNTY
IOWA

MMS CONSULTANTS, INC.
Date: 07-13-2022
Designed by: PVA
Drawn by: RLW
Checked by: HRN
Project No: IC-113224-001
Sheet No: 1 of 1

EASEMENT EXHIBIT

Date	Revision
07-20-2022	PER PAI CLIENT - RLW
07-20-2022	PER RHN REVIEW - RLW

CIVIL ENGINEERS
LAND PLANNERS
LAND SURVEYORS
LANDSCAPE ARCHITECTS
ENVIRONMENTAL SPECIALISTS

1917 S. GILBERT ST.
IOWA CITY, IOWA 52240
(319) 361-8282
www.mmsconsultants.net



NOTICE TO PROCEED

Dated: 7-28-2022

TO: DeLong Construction, Inc.
(Contractor)

ADDRESS: 1320 N. 8th Ave - P.O. Box 488
Washington, IA 52353

PROJECT: Country Club View Subdivision - Plat 1 - Washington, Iowa

JURISDICTION'S CONTRACT NO. -----

CONTRACT FOR Country Club View Subdivision - Plat 1 - Washington, Iowa

You are notified that the Contract Times under the above contract will commence to run on Aug. 8, 2022. By that date, you are to start performing your obligations under the Contract Documents. In accordance with the contract, the work will be fully completed and ready for final payment within 120 working days.

Before you may start any Work at the site, the General Provisions and Covenants provides that you deliver (with copies to ENGINEER and other identified additional insured) certificates of insurance which you are required to purchase and maintain in accordance with the Contract Documents.

Also, before you may start any Work at the site, you must

City of Washington, Iowa
(Jurisdiction)

By: _____
(Authorized Signature)

(Title)



Ahlers & Cooney, P.C.
Attorneys at Law
100 Court Avenue, Suite 600
Des Moines, Iowa 50309-2231
Phone: 515-243-7611
Fax: 515-243-2149
www.ahlerslaw.com
Jason L. Comisky
515.246.0337
jcomisky@ahlerslaw.com

August 12, 2022

Via E-mail Only

Ms. Deanna McCusker
City Administrator
City of Washington
215 E. Washington Street
Washington, Iowa 52353

Re: City of Washington, State of Iowa
\$3,600,000 General Obligation Capital Loan Notes, Series 2022

Dear Deanna:

Enclosed are documents to complete Council action in connection with the authorization for the issuance of the above Notes. **Please print additional copies for execution as indicated in the following itemization of authorizing documents.**

1. The Council procedure consists of the following:
 - (a) Resolution Appointing Registrar and Paying Agent. This resolution appoints UMB Bank, N.A. to serve as Registrar and Paying Agent.
 - (b) Resolution authorizing the issuance of the Notes. The resolution also incorporates by reference the form of the Tax Exemption Certificate and the Continuing Disclosure Certificate.

There are blank spaces appearing in the form of Note set out in the resolution. These need not be completed but may be left blank as a guide since different amounts, dates and percents will be inserted within the blank spaces.

The resolution must be adopted by an affirmative vote equal to a majority of the full Council membership. **Please return one executed copy to us for the transcript.**

- (c) Tax Exemption Certificate. The Tax Exemption Certificate sets out in detail a number of facts, promises and obligations which must be met and agreed to by the City in order to maintain these Notes as tax exempt. This Certificate may contain some blank spaces relating to matters of information dependent upon the resale price of the Notes which are not known and available at this time. The information will be calculated and added to this certificate prior to closing and completed copies of pages with blank spaces will be provided to you. This certificate should be signed and dated. **Please return two executed copies to us for the transcript.**

- (d) Continuing Disclosure Certificate. The form of Continuing Disclosure Certificate, which is described in detail below, is included for approval by the Council under the Resolution

authorizing issuance. This Certificate also should be signed by the Mayor and the Clerk. **Please return two executed copies to us for the transcript.**

2. Closing Certificates and Documents:

(a) Loan Agreement. Please execute all copies and return the same to our office. We will obtain the signature of the purchaser and return a fully executed copy for your file. **Please return two executed copies to us for the transcript.**

(b) Original Notes. The Notes will be delivered under separate cover.

(c) Delivery Certificate. This certificate also should be signed, but not dated. **Please complete and confirm the financial data on page 2,** execute and **return two copies to us for the transcript.** An executed copy will be provided to you after closing.

(d) Transcript Certificate. This certificate is to be executed and sealed in the manner indicated on the second page and may be dated at the time of completion. A notary attestation for all official signatures is required. **Please execute and return two copies to us for the transcript.** An executed copy will be provided to you after closing.

(e) Authentication Order. **Please execute and return two copies to us for the transcript.** An executed copy will be provided to you after closing.

(f) County Auditor's Certificate. A true copy of the authorizing resolution as adopted is to be certified and filed with the Auditor of Washington County. Please certify to such filing on the certificate. **Please return one executed copy to us for the transcript.**

(g) Form 8038-G -- Information Return for Tax Exempt Governmental Obligations. The 8038-G will be delivered under separate cover.

(h) Paying Agent, Note Registrar and Transfer Agent Agreement. **Please execute and return two copies to us for the transcript.** We will obtain signatures from UMB Bank, N.A. and an executed copy will be provided to you after closing.

Tax Exemption

The Tax Exemption Certificate is an important document and contains important information concerning the calculated yield on the Notes and a number of covenants and obligations on the part of the City. This certificate should be retained along with all of your records regarding the use of proceeds, expenditure dates and investment information needed to comply with IRS guidelines. I will not attempt to summarize all of the matters which are included in this certificate but I do want to point out some important ones.

Tax exemption is based in part upon the fact that the use of the facilities to be acquired by the City with the proceeds will be for the benefit of the public and will not be used in the private trade or business of any business or non-tax-exempt entity. The properties acquired with the Note proceeds must not be sold or diverted to any private or nonpublic use unless the significance of that action is reviewed by bond counsel.

The Tax Exemption Certificate sets forth the best knowledge and belief which you have as of today concerning the timely expenditure of the proceeds as the City reasonably expects expenditures to occur. If for any reason the City finds it will be prevented from expending the Note proceeds fully within three years, that matter should be referred to us.

These Notes are also issued under the expectation that the City will be exempt from the requirement to rebate arbitrage earnings to the United States Government since you intend to spend the proceeds of the Notes for construction purposes within two (2) years of issuance and meet the other requirements of the two-year expenditure exemption from the rebate provisions.

These Notes are also issued under the expectation that the City will be exempt from the requirement to rebate arbitrage earnings to the United States Government since you intend to spend the proceeds of the Notes within 18 months of issuance in accordance with the schedule described in Section 3.3 of the Tax Exemption Certificate.

These Notes are also issued under the expectation that you will be exempt from the requirement to rebate arbitrage earnings to the United States Government, because you will issue \$5,000,000 or less of Notes or any similar obligations for public purposes during the calendar year. (This excludes Industrial Development Revenue Notes.) If for any reason you should need to exceed that amount of Note issuance, the matter should be brought to our attention immediately. For this purpose, "Notes" generally includes any debt obligation including warrants, lease-purchase contracts, contracts to purchase, bonds and others.

Also, these Notes are designated as qualified tax-exempt obligations, making them desirable for certain banks as investments and making possible a more favorable interest rate. For this designation to be proper, it is necessary that the City reasonably expects to issue \$10,000,000 or less of Notes or other obligations in the course of this calendar year. If that amount should be exceeded, it would be necessary to review the situation immediately.

There are a number of other general promises and commitments by the City to take or refrain from action, which are necessary to maintain the tax exemption of these Notes. You should recognize that these promises and commitments are required of the City on an ongoing basis and that the possibility of some additional future action does exist.

Continuing Disclosure Certificate

Securities and Exchange Commission Rule 15c2-12, prohibits underwriting and recommendation to the public of the purchase of municipal securities for which adequate secondary market information is not available. The rules apply generally to any municipal offering over \$1,000,000. The City therefore has an obligation to provide continuing disclosure to the marketplace while the Notes are outstanding. The applicable covenants and duties of the City are outlined in the Continuing Disclosure Certificate.

The Continuing Disclosure Certificate requires the City to provide annual financial information and operating data to the Municipal Securities Rulemaking Board's Electronic Municipal Market Access system ("EMMA") so long as the Notes are outstanding, and also to provide notice to EMMA if certain events occur. This information and data must be sent in "searchable PDF" form. You should ensure that your audit and operating data will be available in that format so you may comply. The events which must be reported are detailed in the certificate,

but other events which would be of concern to the rating agencies or Note holders also should be considered for disclosure under the anti-fraud provisions of the federal securities laws.

These disclosure requirements are ongoing and it will be important to designate an appropriate contact person who will have a primary responsibility for preparing and coordinating the filing of the annual financial information, operating data and any event notices.

The penalties for violation of the rule fall ultimately on the issuer of the Notes, because underwriters may be precluded from agreeing to underwrite or bid on Notes of issuers who have not complied with their disclosure obligations. Failure to comply therefore may result in fewer bids and ultimately no bids or the inability to secure an underwriter for an issue.

Closing Matters.

As you know, closing of this issue is scheduled to occur on or about September 1, 2022. At the time of closing, the "Purchaser's" copies of the above items will be delivered to the Purchaser of the Notes in exchange for the agreed purchase price. Our legal opinion also will be delivered to the Purchaser at that time.

Please return executed documents to us by August 25, 2022 to allow sufficient time for review prior to closing.

Should you have any questions, or if we can be of any assistance in completing the enclosed items, please don't hesitate to contact me.

Ahlers & Cooney, P.C.

Sincerely,



Jason L. Comisky
FOR THE FIRM

JLC:ks

Enclosures

cc: Kelsey Brown (via email)
Sally Hart (via email)
Jon Burmeister (via email)
Jennifer Smith (via email)
Melissa Schenck (via email)

ITEMS TO INCLUDE ON AGENDA FOR AUGUST 16, 2022

CITY OF WASHINGTON, IOWA

\$3,600,000 General Obligation Capital Loan Notes, Series 2022

- Resolution Appointing Paying Agent, Note Registrar, and Transfer Agent, Approving the Paying Agent and Note Registrar and Transfer Agent Agreement and Authorizing the Execution of the Agreement.
- Resolution **amending the Resolution** approving and authorizing a form of Loan Agreement and authorizing and providing for the issuance, and levying a tax to pay the Notes; Approval of the Tax Exemption Certificate and Continuing Disclosure Certificate.

NOTICE MUST BE GIVEN PURSUANT TO IOWA CODE
CHAPTER 21 AND THE LOCAL RULES OF THE CITY.

August 16, 2022

The City Council of the City of Washington, State of Iowa, met in _____ session, in the Council Chambers, City Hall, 215 East Washington Street. Washington, Iowa, at _____ .M., on the above date. There were present Mayor _____, in the chair, and the following named Council Members:

Absent: _____

Vacant: _____

* * * * *

Council Member _____ introduced the following resolution entitled "RESOLUTION APPOINTING UMB BANK, N.A. OF WEST DES MOINES, IOWA, TO SERVE AS PAYING AGENT, NOTE REGISTRAR, AND TRANSFER AGENT, APPROVING THE PAYING AGENT AND NOTE REGISTRAR AND TRANSFER AGENT AGREEMENT AND AUTHORIZING THE EXECUTION OF THE AGREEMENT", and moved that the resolution be adopted. Council Member _____ seconded the motion to adopt. The roll was called and the vote was,

AYES: _____

NAYS: _____

Whereupon, the Mayor declared said Resolution duly adopted as follows:

RESOLUTION APPOINTING UMB BANK, N.A. OF WEST
DES MOINES, IOWA, TO SERVE AS PAYING AGENT, NOTE
REGISTRAR, AND TRANSFER AGENT, APPROVING THE
PAYING AGENT AND NOTE REGISTRAR AND TRANSFER
AGENT AGREEMENT AND AUTHORIZING THE
EXECUTION OF THE AGREEMENT

WHEREAS, \$3,600,000 General Obligation Capital Loan Notes, Series 2022, dated September 1, 2022, have been sold and action should now be taken to provide for the maintenance of records, registration of certificates and payment of principal and interest in connection with the issuance of the Notes; and

WHEREAS, this Council has deemed that the services offered by UMB Bank, N.A. of West Des Moines, Iowa, are necessary for compliance with rules, regulations, and requirements governing the registration, transfer and payment of registered notes; and

WHEREAS, a Paying Agent, Note Registrar and Transfer Agent Agreement (hereafter "Agreement") has been prepared to be entered into between the City and UMB Bank, N.A.

NOW, THEREFORE, BE IT RESOLVED BY THE CITY COUNCIL OF THE CITY OF WASHINGTON, STATE OF IOWA:

1. That UMB Bank, N.A. of West Des Moines, Iowa, is hereby appointed to serve as Paying Agent, Note Registrar and Transfer Agent in connection with the issuance of \$3,600,000 General Obligation Capital Loan Notes, Series 2022, dated September 1, 2022.

2. That the Agreement with UMB Bank, N.A. of West Des Moines, Iowa, is hereby approved and that the Mayor and Clerk are authorized to sign the Agreement on behalf of the City.

PASSED AND APPROVED this 16th day of August, 2022.

Mayor

ATTEST:

City Clerk

Council Member _____ introduced the following Resolution entitled "RESOLUTION AMENDING THE 'RESOLUTION AUTHORIZING THE ISSUANCE OF \$1,385,000 GENERAL OBLIGATION CAPITAL LOAN NOTES, SERIES 2021, AND LEVYING A TAX FOR THE PAYMENT THEREOF.' PASSED AND APPROVED ON MARCH 2, 2021, BY SUBSTITUTING A NEW RESOLUITON THEREFOR, APPROVING AND AUTHORIZING A FORM OF LOAN AGREEMENT AND AUTHORIZING AND PROVIDING FOR THE ISSUANCE OF \$3,600,000 GENERAL OBLIGATION CAPITAL LOAN NOTES, SERIES 2022, AND LEVYING A TAX TO PAY SAID NOTES; APPROVAL OF THE TAX EXEMPTION CERTIFICATE AND CONTINUING DISCLOSURE CERTIFICATE" and moved that it be adopted. Council Member _____ seconded the motion to adopt, and the roll being called thereon, the vote was as follows:

AYES: _____

NAYS: _____

Whereupon, the Mayor declared said Resolution duly adopted as follows:

RESOLUTION AMENDING THE 'RESOLUTION AUTHORIZING THE ISSUANCE OF \$1,385,000 GENERAL OBLIGATION CAPITAL LOAN NOTES, SERIES 2021, AND LEVYING A TAX FOR THE PAYMENT THEREOF.' PASSED AND APPROVED ON MARCH 2, 2021, BY SUBSTITUTING A NEW RESOLUITON THEREFOR, APPROVING AND AUTHORIZING A FORM OF LOAN AGREEMENT AND AUTHORIZING AND PROVIDING FOR THE ISSUANCE OF \$3,600,000 GENERAL OBLIGATION CAPITAL LOAN NOTES, SERIES 2022, AND LEVYING A TAX TO PAY SAID NOTES; APPROVAL OF THE TAX EXEMPTION CERTIFICATE AND CONTINUING DISCLOSURE CERTIFICATE

WHEREAS, the Issuer is duly incorporated, organized and exists under and by virtue of the laws and Constitution of the State of Iowa; and

WHEREAS, the Issuer is in need of funds to pay costs of (a) the acquisition, construction, reconstruction, improvement, repair and equipping of water mains and extensions, and real and personal property, useful for providing potable water, (b) equipping the fire

department including the acquisition of self-contained breathing apparatus, and (c) equipping the police department including the acquisition and equipping of a police vehicle, essential corporate purpose(s), and it is deemed necessary and advisable that General Obligation Capital Loan Notes, to the amount of not to exceed \$1,470,000 be authorized for said purpose(s); and

WHEREAS, pursuant to notice published as required by Sections 384.24A and 384.25 of the Code of Iowa, this Council has held a public meeting and hearing upon the proposal to institute proceedings for the issuance of the Notes, and the Council is therefore now authorized to proceed with the issuance of said Notes for such purpose(s); and

WHEREAS, the Issuer is in need of additional funds to pay costs of (a) the acquisition, construction, reconstruction, improvement, repair and equipping of water mains and extensions, and real and personal property, useful for providing potable water, (b) equipping the fire department including the acquisition of self-contained breathing apparatus, and (c) equipping the police department including the acquisition and equipping of a police vehicle, essential corporate purpose(s), and it is deemed necessary and advisable that General Obligation Capital Loan Notes, to the amount of additional not to exceed \$700,000 be authorized for said purpose(s); and

WHEREAS, pursuant to notice published as required by Sections 384.24A and 384.25 of the Code of Iowa, this Council has held a public meeting and hearing upon the proposal to institute proceedings for the issuance of the Notes, and the Council is therefore now authorized to proceed with the issuance of said Notes for such purpose(s); and

WHEREAS, the Issuer is in need of funds to pay costs of aiding in the planning, undertaking, and carrying out of urban renewal projects under the authority of Chapter 403 including the construction of infrastructure in the NLW Subdivision as authorized in Amendment No. 2 to the Washington Unified South Central Residential Urban Renewal Plan, essential corporate purpose project(s), and it is deemed necessary and advisable that the City issue General Obligation Capital Loan Notes, for such purpose(s) to the amount of not to exceed \$800,000 as authorized by Sections 384.24(3)(q), 384.24A, 384.25 and 403.12 of the Code of Iowa; and

WHEREAS, pursuant to notice published as required by Sections 384.24(3)(q), 384.24A, 384.25 and 403.12 this Council has held a public meeting and hearing upon the proposal to institute proceedings for the issuance of said Notes, and all objections, if any, to such Council action made by any resident or property owner of the City were received and considered by the Council; and no petition having been filed, it is the decision of the Council that additional action be taken for the issuance of said Notes for such purpose(s), and that such action is considered to be in the best interests of the City and the residents thereof; and

WHEREAS, the Issuer is in need of funds to pay costs of aiding in the planning, undertaking, and carrying out of urban renewal projects under the authority of Chapter 403 including the construction of infrastructure in the MSJ Subdivision as authorized in Amendment No. 2 to the Washington Unified South Central Residential Urban Renewal Plan, essential corporate purpose project(s), and it is deemed necessary and advisable that the City issue General Obligation Capital Loan Notes, for such purpose(s) to the amount of not to exceed

\$1,000,000 as authorized by Sections 384.24(3)(q), 384.24A, 384.25 and 403.12 of the Code of Iowa; and

WHEREAS, pursuant to notice published as required by Sections 384.24(3)(q), 384.24A, 384.25 and 403.12 this Council has held a public meeting and hearing upon the proposal to institute proceedings for the issuance of said Notes, and all objections, if any, to such Council action made by any resident or property owner of the City were received and considered by the Council; and no petition having been filed, it is the decision of the Council that additional action be taken for the issuance of said Notes for such purpose(s), and that such action is considered to be in the best interests of the City and the residents thereof; and

WHEREAS, the above mentioned Notes were heretofore sold and action should now be taken to issue said Notes conforming to the terms and conditions of the best bid received at the sale; and

WHEREAS, on March 2, 2021, the City Council of said City did adopt a certain Resolution entitled "RESOLUTION AUTHORIZING THE ISSUANCE OF \$1,385,000 GENERAL OBLIGATION CAPITAL LOAN NOTES, SERIES 2021, AND LEVYING A TAX FOR THE PAYMENT THEREOF"; and

WHEREAS, due to certain changes in the overall financing plans of the City, it is necessary to make numerous changes to the Resolution adopted on March 2, 2021; and, therefore, said Council has adopted a new Resolution to be substituted in its entirety for the Resolution previously adopted on March 2, 2021, authorizing the issuance of \$1,385,000 General Obligation Capital Loan Notes, Series 2021.

NOW, THEREFORE, BE IT RESOLVED BY THE CITY COUNCIL OF THE CITY OF WASHINGTON, STATE OF IOWA:

Section 1. Definitions. The following terms shall have the following meanings in this Resolution unless the text expressly or by necessary implication requires otherwise:

- "Authorized Denominations" shall mean \$5,000 or any integral multiple thereof.
- "Beneficial Owner" shall mean, whenever used with respect to a Note, the person in whose name such Note is recorded as the beneficial owner of such Note by a Participant on the records of such Participant or such person's subrogee.
- "Blanket Issuer Letter of Representations" shall mean the Representation Letter from the Issuer to DTC, with respect to the Notes.
- "Cede & Co." shall mean Cede & Co., the nominee of DTC, and any successor nominee of DTC with respect to the Notes.
- "Continuing Disclosure Certificate" shall mean that certain Continuing Disclosure Certificate approved under the terms of this Resolution and to be executed by

the Issuer and dated the date of issuance and delivery of the Notes, as originally executed and as it may be amended from time to time in accordance with the terms thereof.

- "Depository Notes " shall mean the Notes as issued in the form of one global certificate for each maturity, registered in the Registration Books maintained by the Registrar in the name of DTC or its nominee.

- "DTC" shall mean The Depository Trust Company, New York, New York, which will act as security depository for the Note pursuant to the Representation Letter.

- "Issuer" and "City" shall mean the City of Washington, State of Iowa.

- "Loan Agreement" shall mean a Loan Agreement between the Issuer and a lender or lenders in substantially the form attached to and approved by this Resolution.

- "Note Fund" shall mean the fund created in Section 3 of this Resolution.

- "Notes" shall mean \$3,600,000 General Obligation Capital Loan Notes, Series 2022, authorized to be issued by this Resolution.

- "Participants" shall mean those broker-dealers, banks and other financial institutions for which DTC holds Notes as securities depository.

- "Paying Agent" shall mean UMB Bank, N.A., or such successor as may be approved by Issuer as provided herein and who shall carry out the duties prescribed herein as Issuer's agent to provide for the payment of principal of and interest on the Notes as the same shall become due.

- "Project" shall mean (a) the acquisition, construction, reconstruction, improvement, repair and equipping of water mains and extensions, and real and personal property, useful for providing potable water; (b) equipping the fire department including the acquisition of self-contained breathing apparatus; (c) equipping the police department including the acquisition and equipping of a police vehicle; (d) aiding in the planning, undertaking, and carrying out of urban renewal projects under the authority of Chapter 403 including the construction of infrastructure in the NLW Subdivision as authorized in Amendment No. 2 to the Washington Unified South Central Residential Urban Renewal Plan; and (e) aiding in the planning, undertaking, and carrying out of urban renewal projects under the authority of Chapter 403 including the construction of infrastructure in the MSJ Subdivision as authorized in Amendment No. 2 to the Washington Unified South Central Residential Urban Renewal Plan.

- "Project Fund" shall mean the fund required to be established by this Resolution for the deposit of the proceeds of the Notes.

- "Rebate Fund" shall mean the fund so defined in and established pursuant to the Tax Exemption Certificate.
- "Registrar" shall mean UMB Bank, N.A. of West Des Moines, Iowa, or such successor as may be approved by Issuer as provided herein and who shall carry out the duties prescribed herein with respect to maintaining a register of the owners of the Notes. Unless otherwise specified, the Registrar shall also act as Transfer Agent for the Notes.
- "Resolution" shall mean this resolution authorizing the Notes.
- "Tax Exemption Certificate" shall mean the Tax Exemption Certificate approved under the terms of this Resolution and to be executed by the Treasurer and delivered at the time of issuance and delivery of the Notes.
- "Treasurer" shall mean the Finance Director or such other officer as shall succeed to the same duties and responsibilities with respect to the recording and payment of the Notes issued hereunder.

Section 2. Levy and Certification of Annual Tax: Other Funds to be Used.

a) Levy of Annual Tax. That for the purpose of providing funds to pay the principal and interest of the Notes hereinafter authorized to be issued, there is hereby levied for each future year the following direct annual tax on all of the taxable property in the City of Washington, State of Iowa, to-wit:

AMOUNT	FISCAL YEAR (JULY 1 TO JUNE 30) YEAR OF COLLECTION
\$125,371.00*	2022/2023
\$ 235,280.00	2023/2024
\$ 281,530.00	2024/2025
\$ 301,280.00	2025/2026
\$ 320,280.00	2026/2027
\$ 303,530.00	2027/2028
\$ 317,080.00	2028/2029
\$ 335,030.00	2029/2030
\$ 332,230.00	2030/2031
\$ 339,280.00	2031/2032
\$ 340,880.00	2032/2033
\$ 332,180.00	2033/2034
\$ 338,190.00	2034/2035
\$ 333,430.00	2035/2036
\$ 343,200.00	2036/2037

*Levies have been included in budgets previously certified and, after offset, the City collected \$40,413 in FY2021/2022 and expects to collect \$41,310 in FY2022/2023. The

City will use the amounts collected together with other available City funds to pay the principal and interest of the Note coming due in FY2022/2023.

(NOTE: For example the levy to be made and certified against the taxable valuations of January 1, 2022 will be collected during the fiscal year commencing July 1, 2023.)

b) Resolution to be Filed With County Auditor. A certified copy of this Resolution shall be filed with the Auditor of Washington County, Iowa and the Auditor is hereby instructed in and for each of the years as provided, to levy and assess the tax hereby authorized in Section 2 of this Resolution, in like manner as other taxes are levied and assessed, and such taxes so levied in and for each of the years aforesaid be collected in like manner as other taxes of the City are collected, and when collected be used for the purpose of paying principal and interest on said Notes issued in anticipation of the tax, and for no other purpose whatsoever, which action requires a modification and change of the levies originally made in accordance with the Note Resolution certified to and filed in the Washington County Auditor's office on March 9, 2021.

c) Additional City Funds Available. Principal and interest coming due at any time when the proceeds of said tax on hand shall be insufficient to pay the same shall be promptly paid when due from current funds of the City available for that purpose and reimbursement shall be made from such special fund in the amounts thus advanced.

Section 3. Note Fund. Said tax shall be assessed and collected each year at the same time and in the same manner as, and in addition to, all other taxes in and for the City, and when collected they shall be converted into a special fund within the Debt Service Fund to be known as the "2022 GENERAL OBLIGATION CAPITAL LOAN NOTE FUND NO. 1" (the "Note Fund"), which is hereby pledged for and shall be used only for the payment of the principal of and interest on the Notes hereinafter authorized to be issued; and also there shall be apportioned to said fund its proportion of taxes received by the City from property that is centrally assessed by the State of Iowa.

Section 4. Application of Note Proceeds. Proceeds of the Notes, other than accrued interest except as may be provided below, shall be credited to the Project Fund and expended therefrom for the purposes of issuance. Any amounts on hand in the Project Fund shall be available for the payment of the principal of or interest on the Notes at any time that other funds shall be insufficient to the purpose, in which event such funds shall be repaid to the Project Fund at the earliest opportunity. Any balance on hand in the Project Fund and not immediately required for its purposes may be invested not inconsistent with limitations provided by law or this Resolution.

Section 5. Investment of Note Fund Proceeds. All moneys held in the Note Fund, provided for by Section 3 of this Resolution shall be invested in investments permitted by Chapter 12B, Code of Iowa, as amended, or deposited in financial institutions which are members of the Federal Deposit Insurance Corporation and the deposits in which are insured thereby and all such deposits exceeding the maximum amount insured from time to time by FDIC or its equivalent successor in any one financial institution shall be continuously secured in compliance with Chapter 12C of the Code of Iowa, as amended, or otherwise by a valid pledge

of direct obligations of the United States Government having an equivalent market value. All such interim investments shall mature before the date on which the moneys are required for payment of principal of or interest on the Notes as herein provided.

Section 6. Note Details, Execution and Redemption.

a) Note Details. General Obligation Capital Loan Notes of the City in the amount of \$3,600,000, shall be issued to evidence the obligations of the Issuer under the Loan Agreement pursuant to the provisions of Sections 384.24(3)(q), 384.24A, 384.25 and 403.12 of the Code of Iowa for the aforesaid purposes. The Notes shall be issued in one or more series and shall be secured equally and ratably from the sources provided in Section 3 of this Resolution. The Notes shall be designated "GENERAL OBLIGATION CAPITAL LOAN NOTE, SERIES 2022", be dated September 1, 2022, and bear interest from the date thereof, until payment thereof, at the office of the Paying Agent, said interest payable on June 1, 2023, and semiannually thereafter on the 1st day of June and December in each year until maturity at the rates hereinafter provided.

The Notes shall be executed by the manual or facsimile signature of the Mayor and attested by the manual or facsimile signature of the Clerk, and impressed or printed with the seal of the City and shall be fully registered as to both principal and interest as provided in this Resolution; principal, interest and premium, if any, shall be payable at the office of the Paying Agent by mailing of a check to the registered owner of the Note. The Notes shall be in the denomination of \$5,000 or multiples thereof. The Notes shall mature and bear interest as follows:

Principal Amount	Interest Rate	Maturity June 1st
\$ 95,000	3.000%	2023
\$125,000	3.000%	2024
\$175,000	3.000%	2025
\$200,000	3.000%	2026
\$225,000	3.000%	2027
\$215,000	3.000%	2028
\$235,000	3.000%	2029
\$260,000	3.000%	2030
\$265,000	3.000%	2031
\$280,000	3.000%	2032
\$290,000	3.000%	2033
\$290,000	3.100%	2034
\$305,000	3.200%	2035
\$310,000	3.300%	2036
\$330,000	4.000%	2037

b) Redemption.

i. Optional Redemption. Notes maturing after June 1, 2030, may be called for optional redemption by the Issuer on that date or any date thereafter, from any funds regardless of source, in whole or from time to time in part, in any order of maturity and within an annual maturity by lot. The terms of redemption shall be par, plus accrued interest to date of call.

Thirty days' written notice of redemption shall be given to the registered owner of the Note. Failure to give written notice to any registered owner of the Notes or any defect therein shall not affect the validity of any proceedings for the redemption of the Notes. All Notes or portions thereof called for redemption will cease to bear interest after the specified redemption date, provided funds for their redemption are on deposit at the place of payment. Written notice will be deemed completed upon transmission to the owner of record.

If selection by lot within a maturity is required, the Registrar shall designate the Notes to be redeemed by random selection of the names of the registered owners of the entire annual maturity until the total amount of Notes to be called has been reached.

If less than all of a maturity is called for redemption, the Issuer will notify DTC of the particular amount of such maturity to be redeemed prior to maturity. DTC will determine by lot the amount of each Participant's interest in such maturity to be redeemed and each Participant will then select by lot the beneficial ownership interests in such maturity to be redeemed. All prepayments shall be at a price of par plus accrued interest.

c) Urban Renewal Purposes.

The Notes are hereby declared to be issued for essential public and governmental purposes for qualified urban renewal projects.

The Notes shall recite in substance that they have been issued by the City in connection with an urban renewal project as defined by Chapter 403 of the Code of Iowa, and in any suit, action or proceeding involving the validity or enforceability of any note issued hereunder or the security therefor, such Note shall be conclusively deemed to have been issued for such purpose and such project shall be conclusively deemed to have been planned, located and carried out in accordance with the provisions of Chapter 403 of the Code of Iowa.

Section 7. Issuance of Notes in Book-Entry Form: Replacement Notes.

a) Notwithstanding the other provisions of this Resolution regarding registration, ownership, transfer, payment and exchange of the Notes, unless the Issuer determines to permit the exchange of Depository Notes for Notes in Authorized Denominations, the

Notes shall be issued as Depository Notes in denominations of the entire principal amount of each maturity of Notes (or, if a portion of said principal amount is prepaid, said principal amount less the prepaid amount). The Notes must be registered in the name of Cede & Co., as nominee for DTC. Payment of semiannual interest for any Notes registered in the name of Cede & Co. will be made by wire transfer or New York Clearing House or equivalent next day funds to the account of Cede & Co. on the interest payment date for the Notes at the address indicated or in the Representation Letter.

b) The Notes will be initially issued in the form of separate single authenticated fully registered bonds in the amount of each stated maturity of the Notes. Upon initial issuance, the ownership of the Notes will be registered in the registry books of the UMB Bank, N.A. kept by the Paying Agent and Registrar in the name of Cede & Co., as nominee of DTC. The Paying Agent and Registrar and the Issuer may treat DTC (or its nominee) as the sole and exclusive owner of the Notes registered in its name for the purposes of payment of the principal or redemption price of or interest on the Notes, selecting the Notes or portions to be redeemed, giving any notice permitted or required to be given to registered owners of Notes under the Resolution of the Issuer, registering the transfer of Notes, obtaining any consent or other action to be taken by registered owners of the Notes and for other purposes. The Paying Agent, Registrar and the Issuer have no responsibility or obligation to any Participant or Beneficial Owner of the Notes under or through DTC with respect to the accuracy of records maintained by DTC or any Participant; with respect to the payment by DTC or Participant of an amount of principal or redemption price of or interest on the Notes; with respect to any notice given to owners of Notes under the Resolution; with respect to the Participant(s) selected to receive payment in the event of a partial redemption of the Notes, or a consent given or other action taken by DTC as registered owner of the Notes. The Paying Agent and Registrar shall pay all principal of and premium, if any, and interest on the Notes only to Cede & Co. in accordance with the Representation Letter, and all payments are valid and effective to fully satisfy and discharge the Issuer's obligations with respect to the principal of and premium, if any, and interest on the Notes to the extent of the sum paid. DTC must receive an authenticated Bond for each separate stated maturity evidencing the obligation of the Issuer to make payments of principal of and premium, if any, and interest. Upon delivery by DTC to the Paying Agent and Registrar of written notice that DTC has determined to substitute a new nominee in place of Cede & Co., the Notes will be transferable to the new nominee in accordance with this Section.

c) In the event the Issuer determines that it is in the best interest of the Beneficial Owners that they be able to obtain Notes certificates, the Issuer may notify DTC and the Paying Agent and Registrar, whereupon DTC will notify the Participants, of the availability through DTC of Notes certificates. The Notes will be transferable in accordance with this Section. DTC may determine to discontinue providing its services with respect to the Notes at any time by giving notice to the Issuer and the Paying Agent and Registrar and discharging its responsibilities under applicable law. In this event, the Notes will be transferable in accordance with this Section.

d) Notwithstanding any other provision of the Resolution to the contrary, so long as any Note is registered in the name of Cede & Co., as nominee of DTC, all payments

with respect to the principal of and premium, if any, and interest on the Note and all notices must be made and given, respectively to DTC as provided in the Representation letter.

e) In connection with any notice or other communication to be provided to Noteholders by the Issuer or the Paying Agent and Registrar with respect to a consent or other action to be taken by Noteholders, the Issuer or the Paying Agent and Registrar, as the case may be, shall establish a record date for the consent or other action and give DTC notice of the record date not less than 15 calendar days in advance of the record date to the extent possible. Notice to DTC must be given only when DTC is the sole Noteholder.

f) The Representation Letter is on file with DTC and sets forth certain matters with respect to, among other things, notices, consents and approvals by Noteholders and payments on the Notes. The execution and delivery of the Representation Letter to DTC by the Issuer is ratified and confirmed.

g) In the event that a transfer or exchange of the Notes is permitted under this Section, the transfer or exchange may be accomplished upon receipt by the Registrar from the registered owners of the Notes to be transferred or exchanged and appropriate instruments of transfer. In the event Note certificates are issued to holders other than Cede & Co., its successor as nominee for DTC as holder of all the Notes, or other securities depository as holder of all the Notes, the provisions of the Resolution apply to, among other things, the printing of certificates and the method or payment of principal of and interest on the certificates. Any substitute depository shall be designated in writing by the Issuer to the Paying Agent. Any such substitute depository shall be a qualified and registered "clearing agency" as provided in Section 17A of the Securities Exchange Act of 1934, as amended. The substitute depository shall provide for (i) immobilization of the Depository Notes, (ii) registration and transfer of interests in Depository Notes by book entries made on records of the depository or its nominee and (iii) payment of principal of, premium, if any, and interest on the Notes in accordance with and as such interests may appear with respect to such book entries.

h) The officers of the Issuer are authorized and directed to prepare and furnish to the purchaser, and to the attorneys approving the legality of Notes, certified copies of proceedings, ordinances, resolutions and records and all certificates and affidavits and other instruments as may be required to evidence the legality and marketability of the Notes, and all certified copies, certificates, affidavits and other instruments constitute representations of the Issuer as to the correctness of all stated or recited facts.

Section 8. Registration of Notes; Appointment of Registrar; Transfer; Ownership; Delivery; and Cancellation.

a) Registration. The ownership of Notes may be transferred only by the making of an entry upon the books kept for the registration and transfer of ownership of the Notes, and in no other way. UMB Bank, N.A. is hereby appointed as Note Registrar under the terms of this Resolution and under the provisions of a separate agreement with

the Issuer filed herewith which is made a part hereof by this reference. Registrar shall maintain the books of the Issuer for the registration of ownership of the Notes for the payment of principal of and interest on the Notes as provided in this Resolution. All Notes shall be negotiable as provided in Article 8 of the Uniform Commercial Code and Section 384.31 of the Code of Iowa, subject to the provisions for registration and transfer contained in the Notes and in this Resolution.

b) Transfer. The ownership of any Note may be transferred only upon the Registration Books kept for the registration and transfer of Notes and only upon surrender thereof at the office of the Registrar together with an assignment duly executed by the holder or his duly authorized attorney in fact in such form as shall be satisfactory to the Registrar, along with the address and social security number or federal employer identification number of such transferee (or, if registration is to be made in the name of multiple individuals, of all such transferees). In the event that the address of the registered owner of a Note (other than a registered owner which is the nominee of the broker or dealer in question) is that of a broker or dealer, there must be disclosed on the Registration Books the information pertaining to the registered owner required above. Upon the transfer of any such Note, a new fully registered Note, of any denomination or denominations permitted by this Resolution in aggregate principal amount equal to the unmatured and unredeemed principal amount of such transferred fully registered Note, and bearing interest at the same rate and maturing on the same date or dates shall be delivered by the Registrar.

c) Registration of Transferred Notes. In all cases of the transfer of the Notes, the Registrar shall register, at the earliest practicable time, on the Registration Books, the Notes, in accordance with the provisions of this Resolution.

d) Ownership. As to any Note, the person in whose name the ownership of the same shall be registered on the Registration Books of the Registrar shall be deemed and regarded as the absolute owner thereof for all purposes, and payment of or on account of the principal of any such Notes and the premium, if any, and interest thereon shall be made only to or upon the order of the registered owner thereof or his legal representative. All such payments shall be valid and effectual to satisfy and discharge the liability upon such Note, including the interest thereon, to the extent of the sum or sums so paid.

e) Cancellation. All Notes which have been redeemed shall not be reissued but shall be cancelled by the Registrar. All Notes which are cancelled by the Registrar shall be destroyed and a certificate of the destruction thereof shall be furnished promptly to the Issuer; provided that if the Issuer shall so direct, the Registrar shall forward the cancelled Notes to the Issuer.

f) Non-Presentation of Notes. In the event any payment check, wire, or electronic transfer of funds representing payment of principal of or interest on the Notes is returned to the Paying Agent or if any note is not presented for payment of principal at the maturity or redemption date, if funds sufficient to pay such principal of or interest on Notes shall have been made available to the Paying Agent for the benefit of the owner thereof, all liability of the Issuer to the owner thereof for such interest or payment of such

Notes shall forthwith cease, terminate and be completely discharged, and thereupon it shall be the duty of the Paying Agent to hold such funds, without liability for interest thereon, for the benefit of the owner of such Notes who shall thereafter be restricted exclusively to such funds for any claim of whatever nature on his part under this Resolution or on, or with respect to, such interest or Notes. The Paying Agent's obligation to hold such funds shall continue for a period equal to two years and six months following the date on which such interest or principal became due, whether at maturity, or at the date fixed for redemption thereof, or otherwise, at which time the Paying Agent shall surrender any remaining funds so held to the Issuer, whereupon any claim under this Resolution by the Owners of such interest or Notes of whatever nature shall be made upon the Issuer.

g) Registration and Transfer Fees. The Registrar may furnish to each owner, at the Issuer's expense, one note for each annual maturity. The Registrar shall furnish additional Notes in lesser denominations (but not less than the minimum denomination) to an owner who so requests.

Section 9. Reissuance of Mutilated, Destroyed, Stolen or Lost Notes. In case any outstanding Note shall become mutilated or be destroyed, stolen or lost, the Issuer shall at the request of Registrar authenticate and deliver a new Note of like tenor and amount as the Note so mutilated, destroyed, stolen or lost, in exchange and substitution for such mutilated Note to Registrar, upon surrender of such mutilated Note, or in lieu of and substitution for the Note destroyed, stolen or lost, upon filing with the Registrar evidence satisfactory to the Registrar and Issuer that such Note has been destroyed, stolen or lost and proof of ownership thereof, and upon furnishing the Registrar and Issuer with satisfactory indemnity and complying with such other reasonable regulations as the Issuer or its agent may prescribe and paying such expenses as the Issuer may incur in connection therewith.

Section 10. Record Date. Payments of principal and interest, otherwise than upon full redemption, made in respect of any Note, shall be made to the registered holder thereof or to their designated agent as the same appear on the books of the Registrar on the 15th day of the month preceding the payment date. All such payments shall fully discharge the obligations of the Issuer in respect of such Notes to the extent of the payments so made. Upon receipt of the final payment of principal, the holder of the Note shall surrender the Note to the Paying Agent.

Section 11. Execution, Authentication and Delivery of the Notes. Upon the adoption of this Resolution, the Mayor and Clerk shall execute the Notes by their manual or authorized signature and deliver the Notes to the Registrar, who shall authenticate the Notes and deliver the same to or upon order of the Purchaser. No Note shall be valid or obligatory for any purpose or shall be entitled to any right or benefit hereunder unless the Registrar shall duly endorse and execute on such Note a Certificate of Authentication substantially in the form of the Certificate herein set forth. Such Certificate upon any Note executed on behalf of the Issuer shall be conclusive evidence that the Note so authenticated has been duly issued under this Resolution and that the holder thereof is entitled to the benefits of this Resolution.

No Notes shall be authenticated and delivered by the Registrar unless and until there shall have been provided the following:

1. A certified copy of the resolution of Issuer approving the execution of a Loan Agreement and a copy of the Loan Agreement;
2. A written order of Issuer signed by the Treasurer of the Issuer directing the authentication and delivery of the Notes to or upon the order of the Purchaser upon payment of the purchase price as set forth therein;
3. The approving opinion of Ahlers & Cooney, P.C., Bond Counsel, concerning the validity and legality of all the Notes proposed to be issued.

Section 12. Right to Name Substitute Paying Agent or Registrar. Issuer reserves the right to name a substitute, successor Registrar or Paying Agent upon giving prompt written notice to each registered noteholder.

Section 13. Form of Note. Notes shall be printed substantially in the form as follows:

"STATE OF IOWA"
 "COUNTY OF WASHINGTON"
 "CITY OF WASHINGTON"
 "GENERAL OBLIGATION CAPITAL LOAN NOTE"
 "SERIES 2022"
 ESSENTIAL CORPORATE PURPOSE

Rate: _____
 Maturity: _____
 Note Date: September 1, 2022
 CUSIP No.: _____
 "Registered"
 Certificate No. _____
 Principal Amount: \$ _____

The City of Washington, State of Iowa, a municipal corporation organized and existing under and by virtue of the Constitution and laws of the State of Iowa (the "Issuer"), for value received, promises to pay from the source and as hereinafter provided, on the maturity date indicated above, to

(Registration panel to be completed by Registrar or Printer with name of Registered Owner).

or registered assigns, the principal sum of (enter principal amount in long form) THOUSAND DOLLARS in lawful money of the United States of America, on the maturity date shown above, only upon presentation and surrender hereof at the office of UMB Bank, N.A., Paying Agent of this issue, or its successor, with interest on the sum from the date hereof until paid at the rate per annum specified above, payable on June 1, 2023, and semiannually thereafter on the 1st day of June and December in each year.

Interest and principal shall be paid to the registered holder of the Note as shown on the records of ownership maintained by the Registrar as of the 15th day of the month preceding such interest payment date. Interest shall be computed on the basis of a 360-day year of twelve 30-day months.

This Note is issued pursuant to the provisions of Sections 384.24(3)(q), 384.24A, 384.25 and 403.12 of the Code of Iowa, for the purpose of paying costs of (a) the acquisition, construction, reconstruction, improvement, repair and equipping of water mains and extensions, and real and personal property, useful for providing potable water; (b) equipping the fire department including the acquisition of self-contained breathing apparatus; (c) equipping the police department including the acquisition and equipping of a police vehicle; (d) aiding in the planning, undertaking, and carrying out of urban renewal projects under the authority of Chapter 403 including the construction of infrastructure in the NLW Subdivision as authorized in Amendment No. 2 to the Washington Unified South Central Residential Urban Renewal Plan; and (e) aiding in the planning, undertaking, and carrying out of urban renewal projects under the authority of Chapter 403 including the construction of infrastructure in the MSJ Subdivision as authorized in Amendment No. 2 to the Washington Unified South Central Residential Urban Renewal Plan, and in order to evidence the obligations of the Issuer under a certain Loan Agreement dated the date hereof, in conformity to a Resolution of the Council of said City duly passed and approved. For a complete statement of the funds from which and the conditions under which this Note is payable, and the general covenants and provisions pursuant to which this Note is issued, reference is made to the above described Loan Agreement and Resolution.

Unless this certificate is presented by an authorized representative of The Depository Trust Company, a limited purpose trust company ("DTC"), to the Issuer or its agent for registration of transfer, exchange or payment, and any certificate issued is registered in the name of Cede & Co. or such other name as requested by an authorized representative of DTC (and any payment is made to Cede & Co. or to such other Issuer as is requested by an authorized representative of DTC), ANY TRANSFER, PLEDGE OR OTHER USE HEREOF FOR VALUE OR OTHERWISE BY OR TO ANY PERSON IS WRONGFUL inasmuch as the registered owner hereof, Cede & Co., has an interest herein.

Notes maturing after June 1, 2030, may be called for optional redemption by the Issuer and paid before maturity on said date or any date thereafter, from any funds regardless of source, in whole or from time to time in part, in any order of maturity and within an annual maturity by lot. The terms of redemption shall be par, plus accrued interest to date of call.

Thirty days' written notice of redemption shall be given to the registered owner of the Note. Failure to give written notice to any registered owner of the Notes or any defect therein shall not affect the validity of any proceedings for the redemption of the Notes. All notes or portions thereof called for redemption will cease to bear interest after the specified redemption date, provided funds for their redemption are on deposit at the place of payment. Written notice will be deemed completed upon transmission to the owner of record.

If selection by lot within a maturity is required, the Registrar shall designate the Notes to be redeemed by random selection of the names of the registered owners of the entire annual maturity until the total amount of Notes to be called has been reached.

If less than all of a maturity is called for redemption, the Issuer will notify DTC of the particular amount of such maturity to be redeemed prior to maturity. DTC will determine by lot the amount of each Participant's interest in such maturity to be redeemed and each Participant will then select by lot the beneficial ownership interests in such maturity to be redeemed. All prepayments shall be at a price of par plus accrued interest.

Ownership of this Note may be transferred only by transfer upon the books kept for such purpose by UMB Bank, N.A., the Registrar. Such transfer on the books shall occur only upon presentation and surrender of this Note at the office of the Registrar as designated below, together with an assignment duly executed by the owner hereof or his duly authorized attorney in the form as shall be satisfactory to the Registrar. Issuer reserves the right to substitute the Registrar and Paying Agent but shall, however, promptly give notice to registered Noteholders of such change. All notes shall be negotiable as provided in Article 8 of the Uniform Commercial Code and Section 384.31 of the Code of Iowa, subject to the provisions for registration and transfer contained in the Note Resolution.

This Note and the series of which it forms has been issued by the City in connection with an urban renewal project as defined in Chapter 403 of the Code of Iowa, and in any suit, action or proceeding involving the validity or enforceability of any note issued hereunder or the security therefor, such Note shall be conclusively deemed to have been issued for such purpose and such project shall be conclusively deemed to have been planned, located and carried out in accordance with the provisions of Chapter 403 of the Code of Iowa.

This Note is a "qualified tax-exempt obligation" designated by the City for purposes of Section 265(b)(3)(B) of the Internal Revenue Code of 1986.

And it is hereby represented and certified that all acts, conditions and things requisite, according to the laws and Constitution of the State of Iowa, to exist, to be had, to be done, or to be performed precedent to the lawful issue of this Note, have been existent, had, done and performed as required by law; that provision has been made for the levy of a sufficient continuing annual tax on all the taxable property within the territory of the Issuer for the payment of the principal and interest of this Note as the same will respectively become due; that such taxes have been irrevocably pledged for the prompt payment hereof, both principal and interest; and the total indebtedness of the Issuer including this Note, does not exceed the constitutional or statutory limitations.

IN TESTIMONY WHEREOF, the Issuer by its Council, has caused this Note to be signed by the manual or facsimile signature of its Mayor and attested by the manual or facsimile signature of its City Clerk, with the seal of the City printed or impressed hereon, and to be authenticated by the manual signature of an authorized representative of the Registrar, UMB Bank, N.A., West Des Moines, Iowa.

Date of authentication: _____
This is one of the Notes described in the within mentioned
Resolution, as registered by UMB Bank, N.A.

UMB BANK, N.A., Registrar
West Des Moines, Iowa 50266

By: _____
Authorized Signature

Registrar and Transfer Agent: UMB Bank, N.A.

Paying Agent: UMB Bank, N.A.

SEE REVERSE FOR CERTAIN DEFINITIONS

(Seal)
(Signature Block)

CITY OF WASHINGTON, STATE OF IOWA

By: _____ (manual or facsimile signature) _____
Mayor

ATTEST:

By: _____ (manual or facsimile signature) _____
City Clerk

(Information Required for Registration)

ASSIGNMENT

For value received, the undersigned hereby sells, assigns and transfers unto _____ (Social Security or Tax Identification No. _____) the within Note and does hereby irrevocably constitute and appoint _____ attorney in fact to transfer the said Note on the books kept for registration of the within Note, with full power of substitution in the premises.

Dated: _____

(Person(s) executing this Assignment sign(s) here)

SIGNATURE)
GUARANTEED) _____

IMPORTANT - READ CAREFULLY

The signature(s) to this Power must correspond with the name(s) as written upon the face of the certificate(s) or note(s) in every particular without alteration or enlargement or any change whatever. Signature guarantee must be provided in accordance with the prevailing standards and procedures of the Registrar and Transfer Agent. Such standards and procedures may require signature to be guaranteed by certain eligible guarantor institutions that participate in a recognized signature guarantee program.

INFORMATION REQUIRED FOR REGISTRATION OF TRANSFER

Name of Transferee(s) _____
Address of Transferee(s) _____
Social Security or Tax Identification _____
Number of Transferee(s) _____
Transferee is a(n):
Individual* _____ Corporation _____
Partnership _____ Trust _____

*If the Note is to be registered in the names of multiple individual owners, the names of all such owners and one address and social security number must be provided.

The following abbreviations, when used in the inscription on the face of this Note, shall be construed as though written out in full according to applicable laws or regulations:

- TEN COM - as tenants in common
- TEN ENT - as tenants by the entireties
- JT TEN - as joint tenants with rights of survivorship and not as tenants in common

IA UNIF TRANS MIN ACT - Custodian
(Cust) (Minor)
Under Iowa Uniform Transfers to Minors Act.....
(State)

ADDITIONAL ABBREVIATIONS MAY
ALSO BE USED THOUGH NOT IN THE ABOVE LIST

(End of form of Note)

Section 14. Loan Agreement and Closing Documents. The form of Loan Agreement in substantially the form attached to this Resolution is hereby approved and is authorized to be executed and issued on behalf of the Issuer by the Mayor and attested by the City Clerk. The Mayor and City Clerk are authorized and directed to execute, attest, seal and deliver for and on behalf of the City any other additional certificates, documents, or other papers and perform all other acts, including without limitation the execution of all closing documents, as they may deem necessary or appropriate in order to implement and carry out the intent and purposes of this Resolution.

Section 15. Contract Between Issuer and Purchaser. This Resolution constitutes a contract between said City and the purchaser of the Notes.

Section 16. Non-Arbitrage Covenants. The Issuer reasonably expects and covenants that no use will be made of the proceeds from the issuance and sale of the Notes issued hereunder which will cause any of the Notes to be classified as arbitrage notes within the meaning of Sections 148(a) and (b) of the Internal Revenue Code of the United States, as amended, and that throughout the term of the Notes it will comply with the requirements of statutes and regulations issued thereunder.

To the best knowledge and belief of the Issuer, there are no facts or circumstances that would materially change the foregoing statements or the conclusion that it is not expected that the proceeds of the Notes will be used in a manner that would cause the Notes to be arbitrage notes.

Section 17. Approval of Tax Exemption Certificate. Attached hereto is a form of Tax Exemption Certificate stating the Issuer's reasonable expectations as to the use of the proceeds of the Notes. The form of Tax Exemption Certificate is approved. The Issuer hereby agrees to comply with the provisions of the Tax Exemption Certificate and the provisions of the Tax Exemption Certificate are hereby incorporated by reference as part of this Resolution. The Finance Director is hereby directed to make and insert all calculations and determinations necessary to complete the Tax Exemption Certificate at issuance of the Notes to certify as to the reasonable expectations and covenants of the Issuer at that date.

Section 18. Continuing Disclosure. The Issuer hereby covenants and agrees that it will comply with and carry out all of the provisions of the Continuing Disclosure Certificate, and the provisions of the Continuing Disclosure Certificate are hereby incorporated by reference as part

of this Resolution and made a part hereof. Notwithstanding any other provision of this Resolution, failure of the Issuer to comply with the Continuing Disclosure Certificate shall not be considered an event of default under this Resolution; however, any holder of the Notes or Beneficial Owner may take such actions as may be necessary and appropriate, including seeking specific performance by court order, to cause the Issuer to comply with its obligations under the Continuing Disclosure Certificate. For purposes of this section, "Beneficial Owner" means any person which (a) has the power, directly or indirectly, to vote or consent with respect to, or to dispose of ownership of, any Note (including persons holding Notes through nominees, depositories or other intermediaries), or (b) is treated as the owner of any Notes for federal income tax purposes.

Section 19. Additional Covenants, Representations and Warranties of the Issuer. The Issuer certifies and covenants with the purchasers and holders of the Notes from time to time outstanding that the Issuer through its officers, (a) will make such further specific covenants, representations and assurances as may be necessary or advisable; (b) comply with all representations, covenants and assurances contained in the Tax Exemption Certificate, which Tax Exemption Certificate shall constitute a part of the contract between the Issuer and the owners of the Notes; (c) consult with Bond Counsel (as defined in the Tax Exemption Certificate); (d) pay to the United States, as necessary, such sums of money representing required rebates of excess arbitrage profits relating to the Notes; (e) file such forms, statements and supporting documents as may be required and in a timely manner; and (f) if deemed necessary or advisable by its officers, to employ and pay fiscal agents, financial advisors, attorneys and other persons to assist the Issuer in such compliance.

Section 20. Amendment of Resolution to Maintain Tax Exemption. This Resolution may be amended without the consent of any owner of the Notes if, in the opinion of Bond Counsel, such amendment is necessary to maintain tax exemption with respect to the Notes under applicable Federal law or regulations.

Section 21. Qualified Tax-Exempt Obligations. For the sole purpose of qualifying the Notes as "Qualified Tax-Exempt Obligations" pursuant to Section 265(b)(3)(B) of the Internal Revenue Code of the United States, the Issuer hereby designates the Notes as qualified tax-exempt obligations and represents that the reasonably anticipated amount of tax-exempt governmental and qualified 501(c)(3) obligations which will be issued during the current calendar year will not exceed Ten (10) Million Dollars.

Section 22. Repeal of Conflicting Resolutions or Ordinances. All ordinances and resolutions and parts of ordinances and resolutions in conflict herewith are hereby repealed.

Section 23. Severability Clause. If any section, paragraph, clause or provision of this Resolution be held invalid, such invalidity shall not affect any of the remaining provisions hereof, and this Resolution shall become effective immediately upon its passage and approval.

PASSED AND APPROVED this 16th day of August, 2022.

ATTEST:

CERTIFICATE

STATE OF IOWA)
) SS
COUNTY OF WASHINGTON)

I, the undersigned City Clerk of the City of Washington, State of Iowa, do hereby certify that attached is a true and complete copy of the portion of the records of the City showing proceedings of the Council, and the same is a true and complete copy of the action taken by the Council with respect to the matter at the meeting held on the date indicated in the attachment, which proceedings remain in full force and effect, and have not been amended or rescinded in any way; that meeting and all action thereat was duly and publicly held in accordance with a notice of meeting and tentative agenda, a copy of which was timely served on each member of the Council and posted on a bulletin board or other prominent place easily accessible to the public and clearly designated for that purpose at the principal office of the Council pursuant to the local rules of the Council and the provisions of Chapter 21, Code of Iowa, upon reasonable advance notice to the public and media at least twenty-four hours prior to the commencement of the meeting as required by law and with members of the public present in attendance; I further certify that the individuals named therein were on the date thereof duly and lawfully possessed of their respective City offices as indicated therein, that no Council vacancy existed except as may be stated in the proceedings, and that no controversy or litigation is pending, prayed or threatened involving the incorporation, organization, existence or boundaries of the City or the right of the individuals named therein as officers to their respective positions.

WITNESS my hand and the seal of the Council hereto affixed this _____ day of _____, 2022.

City Clerk, City of Washington, State of Iowa

(SEAL)

TAX EXEMPTION CERTIFICATE

of

CITY OF WASHINGTON, COUNTY OF WASHINGTON, STATE OF IOWA, ISSUER

\$3,600,000 General Obligation Capital Loan Notes, Series 2022

This instrument was prepared by:

Ahlers & Cooney, P.C.
100 Court Avenue, Suite 600
Des Moines, Iowa 50309
(515) 243-7611

TABLE OF CONTENTS

This Table of Contents is not a part of this Tax Exemption Certificate and is provided only for convenience of reference.

INTRODUCTION..... - 1 -
ARTICLE I DEFINITIONS - 1 -
ARTICLE II SPECIFIC CERTIFICATIONS, REPRESENTATIONS AND
AGREEMENTS - 4 -
 Section 2.1 Authority to Certify and Expectations - 5 -
 Section 2.2 Receipts and Expenditures of Sale Proceeds - 7 -
 Section 2.3 Purpose of Bonds - 7 -
 Section 2.4 Facts Supporting Tax-Exemption Classification - 7 -
 Section 2.5 Facts Supporting Temporary Periods for Proceeds - 8 -
 Section 2.6 Resolution Funds at Restricted or Unrestricted Yield - 8 -
 Section 2.7 Pertaining to Yields..... - 9 -
ARTICLE III REBATE - 9 -
 Section 3.1 Records - 9 -
 Section 3.2 Rebate Fund - 10 -
 Section 3.3 Exceptions to Rebate..... - 10 -
 Section 3.4 Calculation of Rebate Amount..... - 11 -
 Section 3.5 Rebate Requirements and the Bond Fund..... - 12 -
 Section 3.6 Investment of the Rebate Fund - 12 -
 Section 3.7 Payment to the United States - 12 -
 Section 3.8 Records - 13 -
 Section 3.9 Additional Payments..... - 13 -
ARTICLE IV INVESTMENT RESTRICTIONS..... - 13 -
 Section 4.1 Avoidance of Prohibited Payments..... - 13 -
 Section 4.2 Market Price Requirement - 14 -
 Section 4.3 Investment in Certificates of Deposit - 14 -
 Section 4.4 Investment Pursuant to Investment Contracts and Agreements - 14 -
 Section 4.5 Records - 16 -
 Section 4.6 Investments to be Legal - 17 -
ARTICLE V GENERAL COVENANTS - 17 -
ARTICLE VI AMENDMENTS AND ADDITIONAL AGREEMENTS - 17 -
 Section 6.1 Opinion of Bond Counsel; Amendments..... - 17 -
 Section 6.2 Additional Covenants, Agreements - 17 -
 Section 6.3 Internal Revenue Service Audits - 17 -
 Section 6.4 Amendments - 18 -
ARTICLE VII QUALIFIED TAX EXEMPT OBLIGATIONS..... - 18 -
EXHIBIT A
EXHIBIT B
EXHIBIT C

TAX EXEMPTION CERTIFICATE

CITY OF WASHINGTON, STATE OF IOWA

THIS TAX EXEMPTION CERTIFICATE made and entered into on September 1, 2022, by the City of Washington, County of Washington, State of Iowa (the "Issuer").

INTRODUCTION

This Certificate is executed and delivered in connection with the issuance by the Issuer of its \$3,600,000 General Obligation Capital Loan Notes, Series 2022 (the "Bonds"). The Bonds are issued pursuant to the provisions of the Resolution of the Issuer authorizing the issuance of the Bonds. Such Resolution provides that the covenants contained in this Certificate constitute a part of the Issuer's contract with the owners of the Bonds.

The Issuer recognizes that under the Code (as defined below) the tax-exempt status of the interest received by the owners of the Bonds is dependent upon, among other things, the facts, circumstances, and reasonable expectations of the Issuer as to future facts not in existence at this time, as well as the observance of certain covenants in the future. The Issuer covenants that it will take such action with respect to the Bonds as may be required by the Code, and pertinent legal regulations issued thereunder in order to establish and maintain the tax-exempt status of the Bonds, including the observance of all specific covenants contained in the Resolution and this Certificate.

ARTICLE I

DEFINITIONS

The following terms as used in this Certificate shall have the meanings set forth below. The terms defined in the Resolution shall retain the meanings set forth therein when used in this Certificate. Other terms used in this Certificate shall have the meanings set forth in the Code or in the Regulations.

- "Annual Debt Service" means the principal of and interest on the Bonds scheduled to be paid during a given Bond Year.
- "Bonds" means the \$3,600,000 aggregate principal amount of General Obligation Capital Loan Notes, Series 2022, of the Issuer issued in registered form pursuant to the Resolution.
- "Bond Counsel" means Ahlers & Cooney, P.C., Des Moines, Iowa, or an attorney at law or a firm of attorneys of nationally recognized standing in matters pertaining to the tax-exempt status of interest on obligations issued by states and their political subdivisions, duly admitted to the practice of law before the highest court of any State of the United States of America.
- "Bond Fund" means the Sinking Fund described in the Resolution.

- "Bond Purchase Agreement" means the binding contract in writing for the sale of the Bonds.
- "Bond Year" as defined in Regulation 1.148-1(b), means a one-year period beginning on the day after expiration of the preceding Bond Year. The first Bond Year shall be the one-year or shorter period beginning on the Closing Date and ending on a principal or interest payment date, unless Issuer selects another date.
- "Bond Yield" means that discount rate which produces an amount equal to the Issue Price of the Bonds when used in computing the present value of all payments of principal and interest to be paid on the Bonds, using semiannual compounding on a 360-day year as computed under Regulation 1.148-4.
- "Certificate" means this Tax Exemption Certificate.
- "Closing" means the delivery of the Bonds in exchange for the agreed upon purchase price.
- "Closing Date" means the date of Closing.
- "Code" means the Internal Revenue Code of 1986, as amended, and any statutes which replace or supplement the Internal Revenue Code of 1986.
- "Computation Date" means each five-year period from the Closing Date through the last day of the fifth and each succeeding fifth Bond Year.
- "Excess Earnings" means the amount earned on all Nonpurpose Investments minus the amount which would have been earned if such Nonpurpose Investments were invested at a rate equal to the Bond Yield, plus any income attributable to such excess.
- "Final Bond Retirement Date" means the date on which the Bonds are actually paid in full.
- "Governmental Obligations" means direct general obligations of, or obligations the timely payment of the principal of and interest on which is unconditionally guaranteed by the United States.
- "Gross Proceeds" as defined in Regulation 1.148-1(b), means any Proceeds of the Bonds and any replacement proceeds (as defined in Regulation 1.148-1(c)) of the Bonds.
- "Gross Proceeds Funds" means the Project Fund, Proceeds held to pay cost of issuance, and any other fund or account held for the benefit of the owners of the Bonds or containing Gross Proceeds of the Bonds except the Bond Fund and the Rebate Fund.

- "Issue Price" as defined in Regulation 1.148-1(b) and (f)(2), means the price determined pursuant to the Special Rule for Competitive Sales in accordance with Regulation 1.148-1(f)(2)(iii). The Issuer hereby elects to utilize the Special Rule for Competitive Sales and treats the reasonably expected initial offering price to the public as of the sale date as the issue price of the Bonds. The Purchasers have certified the Issue Price to be not more than \$3,648,646.40, as set forth in Exhibit A.

- "Issuer" means the City of Washington, a municipal corporation in the County of Washington, State of Iowa.

- "Minor Portion of the Bonds", as defined in Regulation 1.148-2(g), means the lesser of five (5) percent of Proceeds or \$100,000. The Minor Portion of the Bonds is computed to be \$100,000.

- "Nonpurpose Investments" means any investment property which is acquired with Gross Proceeds and is not acquired to carry out the governmental purpose of the Bonds, and may include but is not limited to U.S. Treasury bonds, corporate bonds, or certificates of deposit.

- "Proceeds" as defined in Regulation 1.148-1(b), means Sale Proceeds, investment proceeds and transferred proceeds of the Bonds.

- "Project" means the (a) the acquisition, construction, reconstruction, improvement, repair and equipping of water mains and extensions, and real and personal property, useful for providing potable water; (b) equipping the fire department including the acquisition of self-contained breathing apparatus; (c) equipping the police department including the acquisition and equipping of a police vehicle; (d) aiding in the planning, undertaking, and carrying out of urban renewal projects under the authority of Chapter 403 including the construction of infrastructure in the NLW Subdivision as authorized in Amendment No. 2 to the Washington Unified South Central Residential Urban Renewal Plan; and (e) aiding in the planning, undertaking, and carrying out of urban renewal projects under the authority of Chapter 403 including the construction of infrastructure in the MSJ Subdivision as authorized in Amendment No. 2 to the Washington Unified South Central Residential Urban Renewal Plan as more fully described in the Resolution.

- "Project Fund" shall mean the fund required to be established by the Resolution for the deposit of the Proceeds of the Notes.

- "Purchasers" means UMB Bank, N.A. of Kansas City, Missouri, constituting the initial purchasers of the Bonds from the Issuer.

- "Rebate Amount" means the amount computed as described in this Certificate.

- "Rebate Fund" means the fund to be created, if necessary, pursuant to this Certificate.

- "Rebate Payment Date" means a date chosen by the Issuer which is not more than 60 days following each Computation Date or the Final Bond Retirement Date.
- "Regulations" means the Income Tax Regulations, amendments and successor provisions promulgated by the Department of the Treasury under Sections 103, 148 and 149 of the Code, or other Sections of the Code relating to "arbitrage bonds", including without limitation Regulations 1.148-1 through 1.148-11, 1.149(b)-1, 1.149-d(1), 1.150-1 and 1.150-2.
- "Replacement Proceeds" include, but are not limited to, sinking funds, amounts that are pledged as security for an issue, and amounts that are replaced because of a sufficiently direct nexus to a governmental purpose of an issue.
- "Resolution" means the resolution of the Issuer adopted on August 16, 2022, authorizing the issuance of the Bonds.
- "Sale Proceeds" as defined in Regulation 1.148-1(b), means any amounts actually or constructively received from the sale of the Bonds, including amounts used to pay underwriter's discount or compensation and accrued interest other than pre-issuance accrued interest.
- "Sinking Fund" means the Bond Fund.
- "SLGS" means demand deposit Treasury securities of the State and Local Government Series.
- "Tax Exempt Obligations" means bonds or other obligations the interest on which is excludable from the gross income of the owners thereof under Section 103 of the Code and include certain regulated investment companies, stock in tax-exempt mutual funds and demand deposit SLGS.
- "Taxable Obligations" means all investment property, obligations or securities other than Tax Exempt Obligations.
- "Verification Certificate" means the certificate attached to this Certificate as Exhibit A, setting forth the offering prices at which the Purchaser will reoffer and sell the Bonds to the public.

ARTICLE II

SPECIFIC CERTIFICATIONS, REPRESENTATIONS AND AGREEMENTS

The Issuer hereby certifies, represents and agrees as follows:

Section 2.1 Authority to Certify and Expectations

(a) The undersigned officer of the Issuer along with other officers of the Issuer, are charged with the responsibility of issuing the Bonds.

(b) This Certificate is being executed and delivered in part for the purposes specified in Section 1.148-2(b)(2) of the Regulations and is intended (among other purposes) to establish reasonable expectations of the Issuer at this time.

(c) The Issuer has not been notified of any disqualification or proposed disqualification of it by the Commissioner of the Internal Revenue Service as a bond issuer which may certify bond issues under Section 1.148-2(b)(2) of the Regulations.

(d) The certifications, representations and agreements set forth in this Article II are made on the basis of the facts, estimates and circumstances in existence on the date hereof, including the following: (1) with respect to amounts expected to be received from delivery of the Bonds, amounts actually received, (2) with respect to payments of amounts into various funds or accounts, review of the authorizations or directions for such payments made by the Issuer pursuant to the Resolution and this Certificate, (3) with respect to the Issue Price, the certifications of the Purchasers as set forth in the Verification Certificate, (4) with respect to expenditure of the Proceeds of the Bonds, actual expenditures and reasonable expectations of the Issuer as to when the Proceeds will be spent for purposes of the Project, (5) with respect to Bond Yield, review of the Verification Certificate, and (6) with respect to the amount of governmental and qualified 501(c)(3) bonds to be issued during the calendar year, the budgeting and present planning of Issuer. The Issuer has no reason to believe such facts, estimates or circumstances are untrue or incomplete in any material way.

(e) To the best of the knowledge and belief of the undersigned officer of the Issuer, there are no facts, estimates or circumstances that would materially change the representations, certifications or agreements set forth in this Certificate, and the expectations herein set out are reasonable.

(f) No arrangement exists under which the payment of principal or interest on the Bonds would be directly or indirectly guaranteed by the United States or any agency or instrumentality thereof.

(g) After the expiration of any applicable temporary periods, and excluding investments in a bona fide debt service fund or reserve fund, not more than five percent (5%) of the Proceeds of the Bonds will be (a) used to make loans which are guaranteed by the United States or any agency or instrumentality thereof, or (b) invested in federally insured deposits or accounts.

(h) The Issuer will file with the Internal Revenue Service in a timely fashion Form 8038-G, Information Return for Tax-Exempt Governmental Obligations with respect to the Bonds and such other reports required to comply with the Code and applicable Regulations.

(i) The Issuer will take no action which would cause the Bonds to become "private activity bonds" as defined in Section 141 (a) of the Code, including any use of the Project by any person other than a governmental unit if such use will be by other than a member of the general public. None of the Proceeds of the Bonds will be used directly or indirectly to make or finance loans to any person other than a governmental unit.

(j) The Issuer will make no change in the nature or purpose of the Project except as provided in Section 6.1 hereof.

(k) Except as provided in the Resolution, the Issuer will not establish any sinking fund, bond fund, reserve fund, debt service fund or other fund reasonably expected to be used to pay debt service on the Bonds (other than the Bond Fund and any Reserve Fund), exercise its option to redeem Bonds prior to maturity or effect a refunding of the Bonds.

(l) No bonds or other obligations of the Issuer (1) were sold in the 15 days preceding the date of sale of the Bonds, (2) were sold or will be sold within the 15 days after the date of sale of the Bonds, (3) have been delivered in the past 15 days or (4) will be delivered in the next 15 days pursuant to a common plan of financing for the issuance of the Bonds and payable out of substantially the same source of revenues.

(m) None of the Proceeds of the Bonds will be used directly or indirectly to replace funds of the Issuer used directly or indirectly to acquire obligations having a yield higher than the Bond Yield.

(n) No portion of the Bonds is issued for the purpose of investing such portion at a higher yield than the Bond Yield.

(o) The Issuer does not expect that the Proceeds of the Bonds will be used in a manner that would cause them to be "arbitrage bonds" as defined in Section 148(a) of the Code. The Issuer does not expect that the Proceeds of the Bonds will be used in a manner that would cause the interest on the Bonds to be includible in the gross income of the owners of the Bonds under the Code. The Issuer will not intentionally use any portion of the Proceeds to acquire higher yielding investments.

(p) The Issuer will not use the Proceeds of the Bonds to exploit the difference between tax-exempt and taxable interest rates to obtain a material financial advantage.

(q) The Issuer has not issued more Bonds, issued the Bonds earlier, or allowed the Bonds to remain outstanding longer than is reasonably necessary to accomplish the governmental purposes of the Bonds and in fact, the Bonds will not remain outstanding longer than 120% of the economic useful life of the assets financed with the Proceeds of the Bonds.

(r) The Bonds will not be Hedge Bonds as described in Section 149(g)(3) of the Code because the Issuer reasonably expects that it will meet the Expenditure test set forth in Section 2.5(b) hereof and that 50% or more of the Proceeds will not be invested

in Nonpurpose Investments having a substantially guaranteed yield for four or more years.

Except for costs of issuance, all Sale Proceeds and investment earnings thereon will be expended for costs of the type that would be chargeable to capital accounts under the Code pursuant to federal income tax principles if the Issuer were treated as a corporation subject to federal income taxation.

Section 2.2 Receipts and Expenditures of Sale Proceeds

Sale Proceeds (par plus re-offering premium of \$48,646.40), less underwriter's discount of \$35,281, received at Closing are expected to be deposited and expended as follows:

(a) \$ -0- representing pre-issuance accrued interest will be deposited into the Bond Fund and will be used to pay a portion of the interest accruing on the Bonds on the first interest payment date; and

(b) \$ 47,150 representing costs of issuing the Bonds will be used within six months of the Closing Date to pay the costs of issuance of the Bonds (with any excess remaining on deposit in the Project Fund); and

(c) \$3,566,215.40 will be deposited into the Project Fund and will be used together with earnings thereon to pay the costs of the Project and will not exceed the amount necessary to accomplish the governmental purposes of the Bonds; and

Section 2.3 Purpose of Bonds

The Issuer is issuing the Bonds to pay the costs of (a) the acquisition, construction, reconstruction, improvement, repair and equipping of water mains and extensions, and real and personal property, useful for providing potable water; (b) equipping the fire department including the acquisition of self-contained breathing apparatus; (c) equipping the police department including the acquisition and equipping of a police vehicle; (d) aiding in the planning, undertaking, and carrying out of urban renewal projects under the authority of Chapter 403 including the construction of infrastructure in the NLW Subdivision as authorized in Amendment No. 2 to the Washington Unified South Central Residential Urban Renewal Plan; and (e) aiding in the planning, undertaking, and carrying out of urban renewal projects under the authority of Chapter 403 including the construction of infrastructure in the MSJ Subdivision as authorized in Amendment No. 2 to the Washington Unified South Central Residential Urban Renewal Plan.

Section 2.4 Facts Supporting Tax-Exemption Classification

Governmental Bonds

Private Business Use/Private Security or Payment Tests

The Bonds are considered to be governmental bonds, not subject to the provisions of the alternate minimum tax. The Proceeds will be used for the purposes described in

Section 2.3 hereof. These bonds are not private activity bonds because no amount of Proceeds of the Bonds is to be used in a trade or business carried on by a non-governmental unit. Rather, the Proceeds will be used to finance the general government operations and facilities of the Issuer described in Section 2.3 hereof. None of the payment of principal or interest on the Bonds will be derived from, or secured by, money or property used in a trade or business of a non-governmental unit. In addition, none of the governmental operations or facilities of the Issuer being financed with the Proceeds of the Bonds are subject to any lease, management contract or other similar arrangement or to any arrangement for use other than as by the general public.

Private Loan Financing Test

No amount of Proceeds of the Bonds is to be used directly or indirectly to make or finance loans to persons other than governmental units.

Section 2.5 Facts Supporting Temporary Periods for Proceeds

(a) Time Test. Not later than six months after the Closing Date, the Issuer will incur a substantial binding obligation to a third party to expend at least 5% of the net Sale Proceeds of the Bonds.

(b) Expenditure Test. Not less than 85% of the net Sale Proceeds will be expended for Project costs, including the reimbursement of other funds expended to date, within a three-year temporary period from the Closing Date.

(c) Due Diligence Test. Not later than six months after Closing, work on the Project will have commenced and will proceed with due diligence to completion.

(d) Proceeds of the Bonds representing less than six months accrued interest on the Bonds will be spent within six months of this date to pay interest on the Bonds, and will be invested without restriction as to yield for a temporary period not in excess of six months.

Section 2.6 Resolution Funds at Restricted or Unrestricted Yield

(a) Proceeds of the Bonds will be held and accounted for in the manner provided in the Resolution. The Issuer has not and does not expect to create or establish any other bond fund, reserve fund, or similar fund or account for the Bonds. The Issuer has not and will not pledge any moneys or Taxable Obligations in order to pay debt service on the Bonds or restrict the use of such moneys or Taxable Obligations so as to give reasonable assurances of their availability for such purposes.

(b) Any monies which are invested beyond a temporary period are expected to constitute less than a major portion of the Bonds or to be restricted for investment at a yield not greater than one-eighth of one percent above the Bond Yield.

(c) The Issuer has established and will use the Bond Fund primarily to achieve a proper matching of revenues and debt service within each Bond Year and the

Issuer will apply moneys deposited into the Bond Fund to pay the principal of and interest on the Bonds. Such Fund will be depleted at least once each Bond Year except for a reasonable carryover amount. The carryover amount will not exceed the greater of (1) one year's earnings on the Bond Fund or (2) one-twelfth of Annual Debt Service. The Issuer will spend moneys deposited from time to time into such fund within 13 months after the date of deposit. Revenues, intended to be used to pay debt service on the Bonds, will be deposited into the Bond Fund as set forth in the Resolution. The Issuer will spend interest earned on moneys in such fund not more than 12 months after receipt. Accordingly, the Issuer will treat the Bond Fund as a bona fide debt service fund as defined in Regulation 1.148-1(b).

Investment of amounts on deposit in the Bond Fund will not be subject to arbitrage rebate requirements as the Bonds meet the safe harbor set forth in Regulation 1.148-3(k), because the average annual debt service on the Bonds will not exceed \$2,500,000.

- (d) The Minor Portion of the Bonds will be invested without regard to yield.

Section 2.7 Pertaining to Yields

(a) The purchase price of all Taxable Obligations to which restrictions apply under this Certificate as to investment yield or rebate of Excess Earnings, if any, has been and shall be calculated using (i) the price taking into account discount, premium and accrued interest, as applicable, actually paid or (ii) the fair market value if less than the price actually paid and if such Taxable Obligations were not purchased directly from the United States Treasury. The Issuer will acquire all such Taxable Obligations directly from the United States Treasury or in an arm's length transaction without regard to any amounts paid to reduce the yield on such Taxable Obligations. The Issuer will not pay or permit the payment of any amounts (other than to the United States) to reduce the yield on any Taxable Obligations. Obligations pledged to the payment of debt service on the Bonds, after they have been acquired by the Issuer will be treated as though they were acquired for their fair market value on the date of such pledge or deposit.

- (b) Qualified guarantees have not been used in computing yield.

(c) The Bond Yield has been computed as not less than 2.974494 percent. This Bond Yield has been computed on the basis of a purchase price for the Bonds equal to the Issue Price.

ARTICLE III

REBATE

Section 3.1 Records

Sale Proceeds of the Bonds will be held and accounted for in the manner provided in the Resolution. The Issuer will maintain adequate records for funds created by the Resolution and this Certificate including all deposits, withdrawals, transfers from, transfers to, investments,

reinvestments, sales, purchases, redemptions, liquidations and use of money or obligations until six years after the Final Bond Retirement Date.

Section 3.2 Rebate Fund

(a) In the Resolution, the Issuer has covenanted to pay to the United States the Rebate Amount, an amount equal to the Excess Earnings on the Gross Proceeds Funds, if any, at the times and in the manner required or permitted and subject to stated special rules and allowable exceptions.

(b) The Issuer may establish a fund pursuant to the Resolution and this Certificate which is herein referred to as the Rebate Fund. The Issuer will invest and expend amounts on deposit in the Rebate Fund in accordance with this Certificate.

(c) Moneys in the Rebate Fund shall be held by the Issuer or its designee and, subject to Sections 3.4, 3.5 and 6.1 hereof, shall be held for future payment to the United States as contemplated under the provisions of this Certificate and shall not constitute part of the trust estate held for the benefit of the owners of the Bonds or the Issuer.

(d) The Issuer will pay to the United States from legally available money of the Issuer (whether or not such available money is on deposit in any fund or account related to the Bonds) any amount which is required to be paid to the United States.

Section 3.3 Exceptions to Rebate

The Issuer reasonably expects that the Bonds are eligible for one or more exceptions from the arbitrage rebate rules set forth in the Regulations. If any Proceeds are ineligible, or become ineligible, for an exception to the arbitrage rebate rules, the Issuer will comply with the provisions of this Article III. A description of the applicable rebate exception(s) is as follows:

- \$5,000,000 Small Issuer Exception

The reasonably anticipated amount of tax-exempt bonds (other than private activity bonds) which will be issued by the Issuer and all subordinate entities of the Issuer during the calendar year will not exceed \$5,000,000.

- Eighteen-Month Exception

The Gross Proceeds of the Bonds are expected to be expended for the governmental purposes for which the Bonds were issued in accordance with the following schedule:

- 1) 15 percent spent within six months of the Closing Date;
- 2) 60 percent spent within one year of the Closing Date;
- 3) 100 percent spent within eighteen months of the Closing Date (subject to 5 percent retainage for not more than one year).

In any event, the Issuer expects that the 5% reasonable retainage will be spent within 30 months of the Closing Date. For purposes of determining compliance with the six-month and twelve-month spending periods, the amount of investment earnings included shall be based on the Issuer's reasonable expectations that the average annual interest rate on investments will be not more than 6%. For purposes of determining compliance with the eighteen-month spending period, the amount of investment earnings included shall be based on actual earnings. If the Issuer fails to meet the foregoing expenditure schedule, the Issuer shall comply with the arbitrage rebate requirements of the Code.

- Election to Treat as Construction Bonds.

The Issuer reasonably expects that more than 75 percent of the "available construction proceeds" ("ACP") of the Bonds, as defined in Section 148(f)(4)(C)(vi) of the Code, will be used for construction expenditures. ACP includes the issue price of the issue plus the earnings on such issue. Not less than the following percentages of the ACP will be spent within the following periods:

- 1) 10 percent spent within six months of the Closing Date;
- 2) 45 percent spent within one year of the Closing Date;
- 3) 75 percent spent within eighteen months of the Closing Date;
- 4) 100 percent spent within two years of the Closing Date (subject to 5 percent retainage for not more than one year).

In any event, the Issuer expects that the 5% reasonable retainage will be spent within a three-year period beginning on the Closing Date. A failure to spend an amount that does not exceed the lesser of (i) 3% of the issue price or (ii) \$250,000, is disregarded if the Issuer exercises due diligence to complete the Project.

- Election with respect to future earnings

Pursuant to Section 1.148-7(f)(2) of the Regulations, the Issuer elects to use actual investment earnings of the ACP in determining compliance with the above schedule.

If the Issuer fails to meet the foregoing expenditure schedule, the Issuer shall comply with the arbitrage rebate requirements of the Code.

Section 3.4 Calculation of Rebate Amount

(a) As soon after each Computation Date as practicable, the Issuer shall, if necessary, calculate and determine the Excess Earnings on the Gross Proceeds Funds (the "Rebate Amount"). All calculations and determinations with respect to the Rebate Amount will be made on the basis of actual facts as of the Computation Date and reasonable expectations as to future events.

(b) If the Rebate Amount exceeds the amount currently on deposit in the Rebate Fund, the Issuer may deposit an amount in the Rebate Fund such that the balance in the Rebate Fund after such deposit equals the Rebate Amount. If the amount in the Rebate Fund exceeds the Rebate Amount, the Issuer may withdraw such excess amount provided that such withdrawal can be made from amounts originally transferred to the Rebate Fund and not from earnings thereon, which may not be transferred, and only if such withdrawal may be made without liquidating investments at a loss.

Section 3.5 Rebate Requirements and the Bond Fund

It is expected that the Bond Fund described in the Resolution and Section 2.6(c) of this Certificate will be treated as a bona fide debt service fund as defined in Regulation 1.148-1(b). As such, any amount earned during a Bond Year on the Bond Fund and amounts earned on such amounts, if allocated to the Bond Fund, will not be taken into account in calculating the Rebate Amount for the reasons outlined in Section 2.6(c) hereof. However, should the Bond Fund cease to be treated as a bona fide debt service fund, the Bond Fund will become subject to the rebate requirements set forth in Section 3.4 hereof.

Section 3.6 Investment of the Rebate Fund

(a) Immediately upon a transfer to the Rebate Fund, the Issuer may invest all amounts in the Rebate Fund not already invested and held in the Rebate Fund, to the extent possible, in (1) SLGS, such investments to be made at a yield of not more than one-eighth of one percent above the Bond Yield, (2) Tax Exempt Obligations, (3) direct obligations of the United States or (4) certificates of deposit of any bank or savings and loan association. All investments in the Rebate Fund shall be made to mature not later than the next Rebate Payment Date.

(b) If the Issuer invests in SLGS, the Issuer shall file timely subscription forms for such securities (if required). To the extent possible, amounts received from maturing SLGS shall be reinvested immediately in zero yield SLGS maturing on or before the next Rebate Payment Date.

Section 3.7 Payment to the United States

(a) On each Rebate Payment Date, the Issuer will pay to the United States at least ninety percent (90%) of the Rebate Amount less a computation credit of \$1,000 per Bond Year for which the payment is made.

(b) The Issuer will pay to the United States not later than sixty (60) days after the Final Bond Retirement Date all the rebatable arbitrage as of such date and any income attributable to such rebatable arbitrage as described in Regulation 1.148-3(f)(2).

(c) If necessary, on each Rebate Payment Date, the Issuer will mail a check to the Internal Revenue Service Center, Ogden, UT 84201. Each payment shall be accompanied by a copy of Form 8038-T, Arbitrage Rebate, filed with respect to the Bonds or other information reporting form as is required to comply with the Code and applicable Regulations.

Section 3.8 Records

(a) The Issuer will keep and retain adequate records with respect to the Bonds, the Gross Proceeds Funds, the Bond Fund, and the Rebate Fund until six years after the Final Bond Retirement Date. Such records shall include descriptions of all calculations of amounts transferred to the Rebate Fund, if any, and descriptions of all calculations of amounts paid to the United States as required by this Certificate. Such records will also show all amounts earned on moneys invested in such funds, and the actual dates and amounts of all principal, interest and redemption premiums (if any) paid on the Bonds.

(b) Records relating to the investments in such Funds shall completely describe all transfers, deposits, disbursements and earnings including:

(1) a complete list of all investments and reinvestments of amounts in each such Fund including, if applicable, purchase price, purchase date, type of security, accrued interest paid, interest rate, dated date, principal amount, date of maturity, interest payment dates, date of liquidation, receipt upon liquidation, market value of such investment on the Final Bond Retirement Date if held by the Issuer on the Final Bond Retirement Date, and market value of the investment on the date pledged to the payment of the Bonds or the Closing Date if different from the purchase date.

(2) the amount and source of each payment to, and the amount, purpose and payee of each payment from, each such Fund.

Section 3.9 Additional Payments

The Issuer hereby agrees to pay to the United States from legally available money of the Issuer (whether or not such available money is on deposit in any fund or account related to the Bonds) any amount which is required to be paid to the United States, but which is not available in a fund related to the Bonds for transfer to the Rebate Fund or payment to the United States.

ARTICLE IV

INVESTMENT RESTRICTIONS

Section 4.1 Avoidance of Prohibited Payments

The Issuer will not enter into any transaction that reduces the amount required to be deposited into the Rebate Fund or paid to the United States because such transaction results in a smaller profit or a larger loss than would have resulted if the transaction had been at arm's length and had the Bond Yield not been relevant to either party. The Issuer will not invest or direct the investment of any funds in a manner which reduces an amount required to be paid to the United States because such transaction results in a small profit or larger loss than would have resulted if the transaction had been at arm's length and had the Bond Yield not been relevant to the Issuer. In particular, notwithstanding anything to the contrary contained herein or in the Resolution, the

Issuer will not invest or direct the investment of any funds in a manner which would violate any provision of this Article IV.

Section 4.2 Market Price Requirement

(a) The Issuer will not purchase or direct the purchase of Taxable Obligations for more than the then available market price for such Taxable Obligations. The Issuer will not sell, liquidate or direct the sale or liquidation of Taxable Obligations for less than the then available market price.

(b) For purposes of this Certificate, United States Treasury obligations purchased directly from the United States Treasury will be deemed to be purchased at the market price.

Section 4.3 Investment in Certificates of Deposit

(a) Notwithstanding anything to the contrary contained herein or in the Resolution, the Issuer will invest or direct the investment of funds on deposit in any Gross Proceeds Fund, the Bond Fund, and the Rebate Fund, in a certificate of deposit of a bank or savings bank which is permitted by law and by the Resolution only if the purchase price of such a certificate of deposit is treated as its fair market value on the purchase date and if the yield on the certificate of deposit is not less than (1) the yield on reasonably comparable direct obligations of the United States; and (2) the highest yield that is published or posted by the provider to be currently available from the provider on reasonably comparable certificates of deposit offered to the public.

(b) The certificate of deposit described in paragraph 4.3(a) above must be executed by a dealer who maintains an active secondary market in comparable certificates of deposit and must be based on actual trades adjusted to reflect the size and term of that certificate of deposit and the stability and reputation of the bank or savings bank issuing the certificate of deposit.

Section 4.4 Investment Pursuant to Investment Contracts and Agreements

The Issuer will invest or direct the investment of funds on deposit in the Gross Proceeds Funds, the Bond Fund, and the Rebate Fund pursuant to an investment contract (including a repurchase agreement) only if all of the following requirements are satisfied:

(a) The Issuer makes a bona fide solicitation for the purchase of the investment. A bona fide solicitation is a solicitation that satisfies all of the following requirements:

(1) The bid specifications are in writing and are timely forwarded to potential providers.

(2) The bid specifications include all material terms of the bid. A term is material if it may directly or indirectly affect the yield or the cost of the investment.

(3) The bid specifications include a statement notifying potential providers that submission of a bid is a representation that the potential provider did not consult with any other potential provider about its bid, that the bid was determined without regard to any other formal or informal agreement that the potential provider has with the issuer or any other person (whether or not in connection with the Bonds), and that the bid is not being submitted solely as a courtesy to the issuer or any other person for purposes of satisfying the requirements of paragraph (d)(6)(iii)(B)(1) or (2) of Section 1.148-5 of the Regulations.

(4) The terms of the bid specifications are commercially reasonable. A term is commercially reasonable if there is a legitimate business purpose for the term other than to increase the purchase price or reduce the yield of the investment.

(5) For purchases of guaranteed investment contracts only, the terms of the solicitation take into account the Issuer's reasonably expected deposit and drawdown schedule for the amounts to be invested.

(6) All potential providers have an equal opportunity to bid and no potential provider is given the opportunity to review other bids (i.e., a last look) before providing a bid.

(7) At least three reasonably competitive providers are solicited for bids. A reasonably competitive provider is a provider that has an established industry reputation as a competitive provider of the type of investments being purchased.

(b) The bids received by the Issuer meet all of the following requirements:

(1) The Issuer receives at least three bids from providers that the Issuer solicited under a bona fide solicitation meeting the requirements of paragraph (d)(6)(iii)(A) of Section 1.148-5 of the Regulations and that do not have a material financial interest in the issue. A lead underwriter in a negotiated underwriting transaction is deemed to have a material financial interest in the issue until 15 days after the issue date of the issue. In addition, any entity acting as a financial advisor with respect to the purchase of the investment at the time the bid specifications are forwarded to potential providers has a material financial interest in the issue. A provider that is a related party to a provider that has a material financial interest in the issue is deemed to have a material financial interest in the issue.

(2) At least one of the three bids described in paragraph (d)(6)(iii)(B)(1) of Section 1.148-5 of the Regulations is from a reasonably competitive provider, within the meaning of paragraph (d)(6)(iii)(A)(7) of Section 1.148-5 of the Regulations.

(3) If the Issuer uses an agent to conduct the bidding process, the agent did not bid to provide the investment.

(c) The winning bid meets the following requirements:

(1) Guaranteed investment contracts. If the investment is a guaranteed investment contract, the winning bid is the highest yielding bona fide bid (determined net of any broker's fees).

(2) Other investments. If the investment is not a guaranteed investment contract, the winning bid is the lowest cost bona fide bid (including any broker's fees).

(d) The provider of the investments or the obligor on the guaranteed investment contract certifies the administrative costs that it pays (or expects to pay, if any) to third parties in connection with supplying the investment.

(e) The Issuer will retain the following records with the bond documents until three years after the last outstanding bond is redeemed:

(1) For purchases of guaranteed investment contracts, a copy of the contract, and for purchases of investments other than guaranteed investment contracts, the purchase agreement or confirmation.

(2) The receipt or other record of the amount actually paid by the Issuer for the investments, including a record of any administrative costs paid by the Issuer, and the certification under paragraph (d)(6)(iii)(D) of Section 1.148-5 of the Regulations.

(3) For each bid that is submitted, the name of the person and entity submitting the bid, the time and date of the bid, and the bid results.

(4) The bid solicitation form and, if the terms of the purchase agreement or the guaranteed investment contract deviated from the bid solicitation form or a submitted bid is modified, a brief statement explaining the deviation and stating the purpose for the deviation.

(5) For purchases of investments other than guaranteed investment contracts, the cost of the most efficient portfolio of State and Local Government Series Securities, determined at the time that the bids were required to be submitted pursuant to the terms of the bid specifications.

Section 4.5 Records

The Issuer will maintain records of all purchases, sales, liquidations, investments, reinvestments, redemptions, disbursements, deposits, and transfers of amounts on deposit.

Section 4.6 Investments to be Legal

All investments required to be made pursuant to this Certificate shall be made to the extent permitted by law. In the event that any such investment is determined to be ultra vires, it shall be liquidated and the proceeds thereof shall be invested in a legal investment, provided that prior to reinvesting such proceeds, the Issuer shall obtain an opinion of Bond Counsel to the effect that such reinvestment will not cause the Bonds to become arbitrage bonds under Sections 103, 148, 149, or any other applicable provision of the Code.

ARTICLE V

GENERAL COVENANTS

The Issuer hereby covenants to perform all acts within its power necessary to ensure that the reasonable expectations set forth in Article II hereof will be realized. The Issuer reasonably expects to comply with all covenants contained in this Certificate.

ARTICLE VI

AMENDMENTS AND ADDITIONAL AGREEMENTS

Section 6.1 Opinion of Bond Counsel; Amendments

The various provisions of this Certificate need not be observed and this Certificate may be amended or supplemented at any time by the Issuer if the Issuer receives an opinion or opinions of Bond Counsel that the failure to comply with such provisions will not cause any of the Bonds to become "arbitrage bonds" under the Code and that the terms of such amendment or supplement will not cause any of the Bonds to become "arbitrage bonds" under the Code, or otherwise cause interest on any of the Bonds to become includable in gross income for federal income tax purposes.

Section 6.2 Additional Covenants, Agreements

The Issuer hereby covenants to make, execute and enter into (and to take such actions, if any, as may be necessary to enable it to do so) such agreements as may be necessary to comply with any changes in law or regulations in order to preserve the tax-exempt status of the Bonds to the extent that it may lawfully do so. The Issuer further covenants (1) to impose such limitations on the investment or use of moneys or investments related to the Bonds, (2) to make such payments to the United States Treasury, (3) to maintain such records, (4) to perform such calculations, and (5) to perform such other lawful acts as may be necessary to preserve the tax-exempt status of the Bonds.

Section 6.3 Internal Revenue Service Audits

The Internal Revenue Service has not audited the Issuer regarding any obligations issued by or on behalf of the Issuer. To the best knowledge of the Issuer, no such obligations of the Issuer are currently under examination by the Internal Revenue Service.

Section 6.4 Amendments

Except as otherwise provided in Section 6.1 hereof, all the rights, powers, duties and obligations of the Issuer shall be irrevocable and binding upon the Issuer and shall not be subject to amendment or modification by the Issuer.

ARTICLE VII

QUALIFIED TAX EXEMPT OBLIGATIONS

The Issuer, a "qualified small issuer," designates the Bonds as "qualified tax exempt obligations" as defined in Code Section 265(b)(3) and represents that the reasonably anticipated amount of tax-exempt governmental and qualified 501(c)(3) obligations (including for this purpose tax exempt installment sales, lease or lease purchase agreements or other tax exempt obligations) which will be issued during the current calendar year will not exceed ten million dollars (\$10,000,000).

In support of the foregoing, the Issuer states:

(a) In the current calendar year the Issuer has issued governmental or qualified 501(c)(3) obligations as follows:

\$3,600,000 General Obligation Capital Loan Notes, Series 2022, dated September 1, 2022.
(Issue covered by this Certificate.)

(b) The Issuer expects to issue during the remainder of the calendar year governmental or qualified 501(c)(3) obligations as follows:

None

(c) The Issuer has subordinate entities or is subordinate to another entity governed by separate governing bodies which have issued or expect to issue governmental or qualified 501(c)(3) obligations on behalf of the Issuer during the calendar year which must be aggregated under Code Section 265(b)(3)(E) as follows:

None

(d) The Issuer is a member of or affiliated with one or more organizations (such as an Iowa Code Chapter 28E or 28F organization or other multimember body under which more than one governmental entity receives benefits) governed by a separate governing body which has or expects to issue governmental or qualified 501(c)(3) obligations during the calendar year all or a portion of which are allocable to the Issuer under Code Section 265(b)(3)(C)(iii) as follows:

None

IN WITNESS WHEREOF, the Issuer has caused this Certificate to be executed by its duly authorized officer, all as of the day first above written.

Finance Director, City of Washington, State of Iowa

(SEAL)

EXHIBIT A

CITY OF WASHINGTON, STATE OF IOWA
\$3,600,000
GENERAL OBLIGATION CAPITAL LOAN NOTES, SERIES 2022

ISSUE PRICE CERTIFICATE

The undersigned, on behalf of UMB Bank, N.A. of Kansas City, Missouri ("Purchaser"), hereby certifies as set forth below with respect to the sale of the above-captioned obligations (the "Bonds").

1. Reasonably Expected Initial Offering Price.

a) As of the Sale Date, the reasonably expected initial offering prices of the Bonds to the Public by Purchaser are the prices listed in Schedule A (the "Expected Offering Prices"). The Expected Offering Prices are the prices for the Maturities of the Bonds used by Purchaser in formulating its bid to purchase the Bonds. Attached as Schedule B is a true and correct copy of the bid provided by Purchaser to purchase the Bonds.

b) Purchaser was not given the opportunity to review other bids prior to submitting its bid.¹

c) The bid submitted by Purchaser constituted a firm offer to purchase the Bonds.

2. *Defined Terms.*

a) *Maturity* means Bonds with the same credit and payment terms. Bonds with different maturity dates, or Bonds with the same maturity date but different stated interest rates, are treated as separate Maturities.

b) *Public* means any person (including an individual, trust, estate, partnership, association, company, or corporation) other than an Underwriter or a related party to an Underwriter. The term "related party" for purposes of this certificate generally means any two or more persons who have greater than 50 percent common ownership, directly or indirectly.

c) *Sale Date* means the first day on which there is a binding contract in writing for the sale of a Maturity of the Bonds. The Sale Date of the Bonds is July 19, 2022.

d) *Underwriter* means (i) the Purchaser or any person that agrees pursuant to a written contract with the Issuer (or with the lead underwriter to form an underwriting syndicate) to participate in the initial sale of the Bonds to the Public, and (ii) any person that agrees pursuant to a written contract directly or indirectly with a person described in clause (i) of this

¹ Treas. Reg. §1.148-1(f)(3)(i)(B) requires that all bidders have an equal opportunity to bid to purchase bonds. If the bidding process affords an equal opportunity for bidders to review other bids prior to submitting their bids, then this representation should be modified to describe the bidding process.

paragraph to participate in the initial sale of the Bonds to the Public (including a member of a selling group or a party to a retail distribution agreement participating in the initial sale of the Bonds to the Public).

The representations set forth in this certificate are limited to factual matters only. Nothing in this certificate represents Purchaser's interpretation of any laws, including specifically Sections 103 and 148 of the Internal Revenue Code of 1986, as amended, and the Treasury Regulations thereunder. The undersigned understands that the foregoing information will be relied upon by the Issuer with respect to certain of the representations set forth in the Tax Certificate and with respect to compliance with the federal income tax rules affecting the Bonds, and by Ahlers & Cooney, P.C. in connection with rendering its opinion that the interest on the Bonds is excluded from gross income for federal income tax purposes, the preparation of the Internal Revenue Service Form 8038-G, and other federal income tax advice that it may give to the Issuer from time to time relating to the Bonds.

UMB BANK, N.A.

By: _____

Name: _____

Dated: September 1, 2022

SCHEDULE A
EXPECTED OFFERING PRICES
(Attached)

BOND PRICING

 City of Washington, Iowa
 General Obligation Capital Loan Notes, Series 2022
 FINAL

Bond Component	Maturity Date	Amount	Rate	Yield	Price	Yield to Maturity	Call Date	Call Price
Bond Component:								
	06/01/2023	95,000.00	3.000%	2.200%	100.589			
	06/01/2024	125,000.00	3.000%	2.300%	101.191			
	06/01/2025	175,000.00	3.000%	2.400%	101.585			
	06/01/2026	200,000.00	3.000%	2.500%	101.776			
	06/01/2027	225,000.00	3.000%	2.550%	101.998			
	06/01/2028	215,000.00	3.000%	2.600%	102.121			
	06/01/2029	235,000.00	3.000%	2.650%	102.147			
	06/01/2030	260,000.00	3.000%	2.750%	101.731			
	06/01/2031	265,000.00	3.000%	2.850%	101.033	2.865%	06/01/2030	100.000
	06/01/2032	280,000.00	3.000%	2.950%	100.341	2.959%	06/01/2030	100.000
	06/01/2033	290,000.00	3.000%	3.000%	100.000			
	06/01/2034	290,000.00	3.100%	3.100%	100.000			
	06/01/2035	305,000.00	3.200%	3.200%	100.000			
	06/01/2036	310,000.00	3.300%	3.300%	100.000			
	06/01/2037	330,000.00	4.000%	3.200%	105.448	3.523%	06/01/2030	100.000
		3,600,000.00						

Dated Date	09/01/2022	
Delivery Date	09/01/2022	
First Coupon	06/01/2023	
Par Amount	3,600,000.00	
Premium	48,646.40	
Production	3,648,646.40	101.351289%
Underwriter's Discount	-35,281.00	-0.980028%
Purchase Price	3,613,365.40	100.371261%
Accrued Interest		
Net Proceeds	3,613,365.40	

SCHEDULE B

COPY OF UNDERWRITER'S BID

(Attached)

Upcoming Calendar Overview Result Excel Print

Bankers' Bank - Madison , WI's Bid



Washington
\$3,600,000 General Obligation Capital Loan Notes, Series 2022

For the aggregate principal amount of \$3,600,000.00, we will pay you \$3,589,919.40, plus accrued interest from the date of issue to the date of delivery. The Bonds are to bear interest at the following rate(s):

Maturity Date	Amount \$	Coupon %	Yield %	Dollar Price
06/01/2023	95M	3.0000	2.2500	100.552
06/01/2024	125M	3.0000	2.5000	100.848
06/01/2025	175M	3.0000	2.6000	101.052
06/01/2026	200M	3.0000	2.7000	101.060
06/01/2027	225M	3.0000	2.7500	101.103
06/01/2028	215M	3.0000	2.8000	101.052
06/01/2029	235M	3.0000	2.8500	100.912
06/01/2030	260M	3.0000	2.9000	100.686
06/01/2031	265M	3.0000	2.9500	100.341
06/01/2032	280M	3.0000	3.0000	100.000
06/01/2033	290M	3.1000	3.1000	100.000
06/01/2034	290M	3.2000	3.2000	100.000
06/01/2035	305M	3.3000	3.3000	100.000
06/01/2036	310M	3.3500	3.3500	100.000
06/01/2037	330M	3.4000	3.4000	100.000

Total Interest Cost: \$1,016,587.50
Discount: \$10,080.60
Net Interest Cost: \$1,026,668.10
TIC: 3.203759
Time Last Bid Received On: 07/19/2022 9:57:10 CDST

This proposal is made subject to all of the terms and conditions of the Official Bid Form, the Official Notice of Sale, and the Preliminary Official Statement, all of which are made a part hereof.

Bidder: Bankers' Bank, Madison , WI
Contact: Thomas Underkofler
Title:
Telephone: 608-829-5752
Fax:

Issuer Name: City of Washington Company Name: _____

Accepted By: _____ Accepted By: _____

Date: _____ Date: _____

CITY OF WASHINGTON, STATE OF IOWA
\$3,600,000
GENERAL OBLIGATION CAPITAL LOAN NOTES, SERIES 2022

CERTIFICATE OF MUNICIPAL ADVISOR

The undersigned, on behalf of PFM Financial Advisors, LLC of Des Moines, Iowa (the "Municipal Advisor"), as the municipal advisor to City of Washington, Iowa, in connection with the issuance of the above-captioned obligations (the "Bonds"), has assisted the Issuer in soliciting and receiving bids from potential underwriters in connection with the sale of the Bonds in a competitive bidding process in which bids were requested for the purchase of the Bonds at specified written terms, and hereby certifies as set forth below with respect to the bidding process and award of the Bonds.

1. The Bonds were offered for sale at specified written terms more particularly described in the Notice of Sale, which was distributed to potential bidders, a copy of which is attached to this certificate as Attachment 1.

2. The Terms of Offering was disseminated electronically through I-DEAL® an internet bid system and Bloomberg ® financial software. Notification of the competitive sale was published in The Bond Buyer ® newspaper in its upcoming sales calendar. The Preliminary Official Statement was distributed via electronic mail to underwriting firms actively bidding on competitive sales in the Midwest. These methods of distribution of the terms of offering and Preliminary Official Statement are regularly used for proposes of disseminating notices of the sale of new issuances of municipal bonds, and notices disseminated in such manner are widely available to potential bidders.

3. To the knowledge of the Municipal Advisor, all bidders were offered an equal opportunity to bid to purchase the Bonds so that, for example, if the bidding process afforded any opportunity for bidders to review other bids before providing a bid, no bidder was given an opportunity to review other bids that was not equally given to all other bidders (that is, no exclusive "last-look").

4. The Issuer received bids from at least three bidders who represented that they have established industry reputations for underwriting new issuances of municipal bonds. Based upon the Municipal Advisor's knowledge and experience in acting as the municipal advisor for other municipal issues, the Municipal Advisor believes those representations to be accurate. Copies of the bids received are attached to this certificate as Attachment 2.

5. The winning bidder was UMB Bank, N.A. of Kansas City, Missouri (the "Purchaser"), whose bid was determined to be the best conforming bid in accordance with the terms set forth in the Notice of Sale, as shown in the bid comparison attached as Attachment 3 to this certificate. The Issuer awarded the Bonds to the Purchaser.

The representations set forth in this certificate are limited to factual matters only. Nothing in this certificate represents the Municipal Advisor's interpretation of any laws, including specifically Sections 103 and 148 of the Internal Revenue Code of 1986, as amended, and the Treasury Regulations thereunder. The undersigned understands that the foregoing

information will be relied upon by the Issuer with respect to certain of the representations set forth in the Tax Certificate and with respect to compliance with the federal income tax rules affecting the Bonds, and by Ahlers & Cooney, P.C. in connection with rendering its opinion that the interest on the Bonds is excluded from gross income for federal income tax purposes, the preparation of the Internal Revenue Service Form 8038-G, and other federal income tax advice that it may give to the Issuer from time to time relating to the Bonds. No other persons may rely on the representations set forth in this certificate without the prior written consent of the Municipal Advisor.

PFM FINANCIAL ADVISORS LLC

By: _____

Name: _____

Dated: September 1, 2022

ATTACHMENT 1

NOTICE OF SALE

(Attached)

ATTACHMENT 2

BIDS RECEIVED

(Attached)

Upcoming Calendar Overview Result Excel Print

UMB Bank N.A. - Kansas City , MO's Bid



Washington
\$3,600,000 General Obligation Capital Loan Notes, Series 2022

For the aggregate principal amount of \$3,600,000.00, we will pay you \$3,613,365.40, plus accrued interest from the date of issue to the date of delivery. The Bonds are to bear interest at the following rate(s):

Maturity Date	Amount \$	Coupon %	Yield %	Dollar Price
06/01/2023	95M	3.0000	2.2000	100.589
06/01/2024	125M	3.0000	2.3000	101.191
06/01/2025	175M	3.0000	2.4000	101.585
06/01/2026	200M	3.0000	2.5000	101.776
06/01/2027	225M	3.0000	2.5500	101.998
06/01/2028	215M	3.0000	2.6000	102.121
06/01/2029	235M	3.0000	2.6500	102.147
06/01/2030	260M	3.0000	2.7500	101.731
06/01/2031	265M	3.0000	2.8500	101.033
06/01/2032	280M	3.0000	2.9500	100.341
06/01/2033	290M	3.0000	3.0000	100.000
06/01/2034	290M	3.1000	3.1000	100.000
06/01/2035	305M	3.2000	3.2000	100.000
06/01/2036	310M	3.3000	3.3000	100.000
06/01/2037	330M	4.0000	3.2000	105.448

Total Interest Cost: \$1,033,247.50
 Premium: \$13,365.40
 Net Interest Cost: \$1,019,882.10
 TIC: 3.164531
 Time Last Bid Received On: 07/19/2022 9:55:43 CDST

This proposal is made subject to all of the terms and conditions of the Official Bid Form, the Official Notice of Sale, and the Preliminary Official Statement, all of which are made a part hereof.

Bidder: UMB Bank N.A., Kansas City , MO
 Contact: Kristin Koziol
 Title: VP
 Telephone: 816-860-7223
 Fax: 816-843-4325

Issuer Name: City of Washington Company Name: _____

Accepted By: _____ Accepted By: _____

Date: _____ Date: _____

Upcoming Calendar Overview Result Excel Print

Bankers' Bank - Madison , WI's Bid



Washington
\$3,600,000 General Obligation Capital Loan Notes, Series 2022

For the aggregate principal amount of \$3,600,000.00, we will pay you \$3,589,919.40, plus accrued interest from the date of issue to the date of delivery. The Bonds are to bear interest at the following rate(s):

Maturity Date	Amount \$	Coupon %	Yield %	Dollar Price
06/01/2023	95M	3.0000	2.2500	100.552
06/01/2024	125M	3.0000	2.5000	100.848
06/01/2025	175M	3.0000	2.6000	101.052
06/01/2026	200M	3.0000	2.7000	101.060
06/01/2027	225M	3.0000	2.7500	101.103
06/01/2028	215M	3.0000	2.8000	101.052
06/01/2029	235M	3.0000	2.8500	100.912
06/01/2030	260M	3.0000	2.9000	100.686
06/01/2031	265M	3.0000	2.9500	100.341
06/01/2032	280M	3.0000	3.0000	100.000
06/01/2033	290M	3.1000	3.1000	100.000
06/01/2034	290M	3.2000	3.2000	100.000
06/01/2035	305M	3.3000	3.3000	100.000
06/01/2036	310M	3.3500	3.3500	100.000
06/01/2037	330M	3.4000	3.4000	100.000

Total Interest Cost: \$1,016,587.50
Discount: \$10,080.60
Net Interest Cost: \$1,026,668.10
TIC: 3.203759
Time Last Bid Received On: 07/19/2022 9:57:10 CDST

This proposal is made subject to all of the terms and conditions of the Official Bid Form, the Official Notice of Sale, and the Preliminary Official Statement, all of which are made a part hereof.

Bidder: Bankers' Bank, Madison , WI
Contact: Thomas Underkofler
Title:
Telephone: 608-829-5752
Fax:

Issuer Name: City of Washington Company Name: _____

Accepted By: _____ Accepted By: _____

Date: _____ Date: _____

Upcoming Calendar Overview Result Excel Print

HilltopSecurities - Dallas , TX's Bid



**Washington
\$3,600,000 General Obligation Capital Loan Notes, Series 2022**

For the aggregate principal amount of \$3,600,000.00, we will pay you \$3,811,695.15, plus accrued interest from the date of issue to the date of delivery. The Bonds are to bear interest at the following rate(s):

Maturity Date	Amount \$	Coupon %	Yield %	Dollar Price
06/01/2023	95M	4.0000	1.6000	101.780
06/01/2024	125M	4.0000	1.8500	103.683
06/01/2025	175M	4.0000	2.0000	105.323
06/01/2026	200M	4.0000	2.1500	106.628
06/01/2027	225M	4.0000	2.2400	107.886
06/01/2028	215M	4.0000	2.3800	108.654
06/01/2029	235M	4.0000	2.5000	109.260
06/01/2030	260M	4.0000	2.6000	109.766
06/01/2031	265M	4.0000	2.7000	109.032
06/01/2032	280M	4.0000	2.8000	108.304
06/01/2033	290M	4.0000	2.9000	107.582
06/01/2034	290M	4.0000	3.0000	106.865
06/01/2035	305M	4.0000	3.1000	106.154
06/01/2036				
06/01/2037	640M	4.0000	3.2000	105.448

Total Interest Cost: \$1,280,800.00
 Premium: \$211,695.15
 Net Interest Cost: \$1,069,104.85
 TIC: 3.212942
 Time Last Bid Received On:07/19/2022 9:57:54 CDST

This proposal is made subject to all of the terms and conditions of the Official Bid Form, the Official Notice of Sale, and the Preliminary Official Statement, all of which are made a part hereof.

Bidder: HilltopSecurities, Dallas , TX
 Contact: William Evans
 Title: Managing Director
 Telephone:214-859-9421
 Fax:

Issuer Name: City of Washington Company Name: _____

Accepted By: _____ Accepted By: _____

Date: _____ Date: _____

Upcoming Calendar Overview Result Excel Print

Robert W. Baird & Co., Inc. - Milwaukee , WI's Bid



Washington
\$3,600,000 General Obligation Capital Loan Notes, Series 2022

For the aggregate principal amount of \$3,600,000.00, we will pay you \$3,710,542.60, plus accrued interest from the date of issue to the date of delivery. The Bonds are to bear interest at the following rate(s):

Maturity Date	Amount \$	Coupon %	Yield %	Dollar Price
06/01/2023	95M	5.0000	1.8500	102.332
06/01/2024	125M	5.0000	2.0000	105.130
06/01/2025	175M	5.0000	2.1500	107.567
06/01/2026	200M	5.0000	2.2500	109.832
06/01/2027	225M	5.0000	2.4000	111.602
06/01/2028	215M	5.0000	2.5500	113.022
06/01/2029	235M	5.0000	2.6500	114.433
06/01/2030	260M	5.0000	2.7500	115.604
06/01/2031	265M	3.0000	2.8500	101.033
06/01/2032	280M	3.0000	3.0000	100.000
06/01/2033	290M	3.0500	3.0500	100.000
06/01/2034	290M	3.1500	3.1500	100.000
06/01/2035	305M	3.2500	3.2500	100.000
06/01/2036	310M	3.3500	3.3500	100.000
06/01/2037	330M	3.4500	3.4500	100.000

Total Interest Cost: \$1,162,364.37
 Premium: \$110,542.60
 Net Interest Cost: \$1,051,821.77
 TIC: 3.246095
 Time Last Bid Received On: 07/19/2022 9:50:32 CDST

This proposal is made subject to all of the terms and conditions of the Official Bid Form, the Official Notice of Sale, and the Preliminary Official Statement, all of which are made a part hereof.

Bidder: Robert W. Baird & Co., Inc., Milwaukee , WI
 Contact: Peter Anderson
 Title:
 Telephone: 414-765-7331
 Fax:

Issuer Name: City of Washington Company Name: _____

Accepted By: _____ Accepted By: _____

Date: _____ Date: _____

Upcoming Calendar Overview Result Excel Print

BOK Financial Securities, Inc. - Dallas , TX's Bid



Washington
\$3,600,000 General Obligation Capital Loan Notes, Series 2022

For the aggregate principal amount of \$3,600,000.00, we will pay you \$3,715,605.50, plus accrued interest from the date of issue to the date of delivery. The Bonds are to bear interest at the following rate(s):

Maturity Date	Amount \$	Coupon %	Yield %	Dollar Price
06/01/2023	95M	4.0000	1.7500	101.667
06/01/2024	125M	4.0000	1.9000	103.595
06/01/2025	175M	4.0000	2.1000	105.048
06/01/2026	200M	4.0000	2.2500	106.256
06/01/2027	225M	4.0000	2.3500	107.372
06/01/2028	215M	4.0000	2.5000	107.984
06/01/2029	235M	4.0000	2.6500	108.290
06/01/2030	260M	4.0000	2.7000	109.032
06/01/2031	265M	3.5000	2.7500	105.199
06/01/2032	280M	3.5000	2.8500	104.488
06/01/2033	290M	3.5000	3.0000	103.431
06/01/2034	290M	3.5000	3.1000	102.733
06/01/2035	305M	3.5000	3.2000	102.041
06/01/2036	310M	3.7500	3.3000	103.051
06/01/2037	330M	3.7500	3.3500	102.706

Total Interest Cost: \$1,180,662.50
 Premium: \$115,605.50
 Net Interest Cost: \$1,065,057.00
 TIC: 3.260942
 Time Last Bid Received On: 07/19/2022 9:38:38 CDST

This proposal is made subject to all of the terms and conditions of the Official Bid Form, the Official Notice of Sale, and the Preliminary Official Statement, all of which are made a part hereof.

Bidder: BOK Financial Securities, Inc., Dallas , TX
 Contact: Allen Mattson
 Title:
 Telephone: 414-203-6558
 Fax: 214-576-0870

Issuer Name: City of Washington Company Name: _____

Accepted By: _____ Accepted By: _____

Date: _____ Date: _____

Upcoming Calendar Overview Result Excel Print

Northland Securities, Inc. - Minneapolis , MN's Bid



Washington
\$3,600,000 General Obligation Capital Loan Notes, Series 2022

For the aggregate principal amount of \$3,600,000.00, we will pay you \$3,616,108.65, plus accrued interest from the date of issue to the date of delivery. The Bonds are to bear interest at the following rate(s):

Maturity Date	Amount \$	Coupon %	Yield %	Dollar Price
06/01/2023	95M	4.0000	2.0000	101.478
06/01/2024	125M	4.0000	2.2000	103.070
06/01/2025	175M	4.0000	2.3000	104.502
06/01/2026	200M	4.0000	2.4000	105.702
06/01/2027	225M	4.0000	2.5000	106.675
06/01/2028	215M	4.0000	2.6000	107.429
06/01/2029	235M	4.0000	2.7000	107.969
06/01/2030	260M	4.0000	2.8000	108.304
06/01/2031	265M	3.0000	2.9000	100.686
06/01/2032	280M	3.0000	3.0000	100.000
06/01/2033	290M	3.1000	3.1000	100.000
06/01/2034	290M	3.2000	3.2000	100.000
06/01/2035	305M	3.3000	3.3000	100.000
06/01/2036	310M	3.4000	3.4000	100.000
06/01/2037	330M	3.5000	3.5000	100.000

Total Interest Cost: \$1,097,861.25
 Premium: \$16,108.65
 Net Interest Cost: \$1,081,752.60
 TIC: 3.376687
 Time Last Bid Received On:07/19/2022 9:59:59 CDST

This proposal is made subject to all of the terms and conditions of the Official Bid Form, the Official Notice of Sale, and the Preliminary Official Statement, all of which are made a part hereof.

Bidder: Northland Securities, Inc., Minneapolis , MN
 Contact: Dustin Siehr
 Title:
 Telephone:414-908-0422
 Fax: 414-755-1831

Issuer Name: City of Washington Company Name: _____

Accepted By: _____ Accepted By: _____

Date: _____ Date: _____

Upcoming Calendar Overview Result Excel Print

Bernardi Securities, Inc. - Northfield , IL's Bid



**Washington
\$3,600,000 General Obligation Capital Loan Notes, Series 2022**

For the aggregate principal amount of \$3,600,000.00, we will pay you \$3,754,730.85, plus accrued interest from the date of issue to the date of delivery. The Bonds are to bear interest at the following rate(s):

Maturity Date	Amount \$	Coupon %	Yield %	Dollar Price
06/01/2023	95M	4.0000	1.7000	101.704
06/01/2024	125M	4.0000	2.0000	103.420
06/01/2025	175M	4.0000	2.2000	104.775
06/01/2026	200M	4.0000	2.3000	106.071
06/01/2027	225M	4.0000	2.4500	106.907
06/01/2028	215M	4.0000	2.6500	107.152
06/01/2029	235M	4.0000	2.7000	107.969
06/01/2030	260M	4.0000	2.8000	108.304
06/01/2031	265M	4.0000	2.9000	107.582
06/01/2032	280M	4.0000	3.0000	106.865
06/01/2033	290M	4.0000	3.1000	106.154
06/01/2034	290M	4.0000	3.2000	105.448
06/01/2035	305M	4.0000	3.3000	104.748
06/01/2036	310M	4.0000	3.4000	104.053
06/01/2037	330M	4.0000	3.5000	103.363

Total Interest Cost: \$1,280,800.00
 Premium: \$154,730.85
 Net Interest Cost: \$1,126,069.15
 TIC: 3.418143
 Time Last Bid Received On: 07/19/2022 9:52:34 CDST

This proposal is made subject to all of the terms and conditions of the Official Bid Form, the Official Notice of Sale, and the Preliminary Official Statement, all of which are made a part hereof.

Bidder: Bernardi Securities, Inc., Northfield , IL
 Contact: Gineen Destefano
 Title:
 Telephone: 312-281-2019
 Fax:

Issuer Name: City of Washington Company Name: _____

Accepted By: _____ Accepted By: _____

Date: _____ Date: _____

ATTACHMENT 3
BID COMPARISON
(Attached)

City of Washington, Iowa
General Obligation Capital Loan Notes, Series 2022

TIC Calculation

Period Ending	UMB Bank Debt Service	Bankers' Bank Debt Service	Hilltop Debt Service	Robert W. Baird Debt Service	BOK Financial Debt Service	Northland Debt Service	Bernardi Debt Service
09-01-22	(3,613,365.40)	(3,589,919.40)	(3,811,695.15)	(3,710,542.60)	(3,715,605.50)	(3,616,108.65)	(3,754,730.85)
06-01-23	179,847.50	179,142.50	203,000.00	201,884.38	196,437.50	190,981.25	203,000.00
12-01-23	55,140.00	54,670.00	70,100.00	68,881.25	65,725.00	62,087.50	70,100.00
06-01-24	180,140.00	179,670.00	195,100.00	193,881.25	190,725.00	187,087.50	195,100.00
12-01-24	53,265.00	52,795.00	67,600.00	65,756.25	63,225.00	59,587.50	67,600.00
06-01-25	228,265.00	227,795.00	242,600.00	240,756.25	238,225.00	234,587.50	242,600.00
12-01-25	50,640.00	50,170.00	64,100.00	61,381.25	59,725.00	56,087.50	64,100.00
06-01-26	250,640.00	250,170.00	264,100.00	261,381.25	259,725.00	256,087.50	264,100.00
12-01-26	47,640.00	47,170.00	60,100.00	56,381.25	55,725.00	52,087.50	60,100.00
06-01-27	272,640.00	272,170.00	285,100.00	281,381.25	280,725.00	277,087.50	285,100.00
12-01-27	44,265.00	43,795.00	55,600.00	50,756.25	51,225.00	47,587.50	55,600.00
06-01-28	259,265.00	258,795.00	270,600.00	265,756.25	266,225.00	262,587.50	270,600.00
12-01-28	41,040.00	40,570.00	51,300.00	45,381.25	46,925.00	43,287.50	51,300.00
06-01-29	276,040.00	275,570.00	286,300.00	280,381.25	281,925.00	278,287.50	286,300.00
12-01-29	37,515.00	37,045.00	46,600.00	39,506.25	42,225.00	38,587.50	46,600.00
06-01-30	297,515.00	297,045.00	306,600.00	299,506.25	302,225.00	298,587.50	306,600.00
12-01-30	33,615.00	33,145.00	41,400.00	33,006.25	37,025.00	33,387.50	41,400.00
06-01-31	298,615.00	298,145.00	306,400.00	298,006.25	302,025.00	298,387.50	306,400.00
12-01-31	29,640.00	29,170.00	36,100.00	29,031.25	32,387.50	29,412.50	36,100.00
06-01-32	309,640.00	309,170.00	316,100.00	309,031.25	312,387.50	309,412.50	316,100.00
12-01-32	25,440.00	24,970.00	30,500.00	24,831.25	27,487.50	25,212.50	30,500.00
06-01-33	315,440.00	314,970.00	320,500.00	314,831.25	317,487.50	315,212.50	320,500.00
12-01-33	21,090.00	20,475.00	24,700.00	20,408.75	22,412.50	20,717.50	24,700.00
06-01-34	311,090.00	310,475.00	314,700.00	310,408.75	312,412.50	310,717.50	314,700.00
12-01-34	16,595.00	15,835.00	18,900.00	15,841.25	17,337.50	16,077.50	18,900.00
06-01-35	321,595.00	320,835.00	323,900.00	320,841.25	322,337.50	321,077.50	323,900.00
12-01-35	11,715.00	10,802.50	12,800.00	10,885.00	12,000.00	11,045.00	12,800.00
06-01-36	321,715.00	320,802.50	322,800.00	320,885.00	322,000.00	321,045.00	322,800.00
12-01-36	6,600.00	5,610.00	6,600.00	5,692.50	6,187.50	5,775.00	6,600.00
06-01-37	336,600.00	335,610.00	336,600.00	335,692.50	336,187.50	335,775.00	336,600.00
	4,633,247.50	4,616,587.50	4,880,800.00	4,762,364.38	4,780,662.50	4,697,861.25	4,880,800.00
Par	3,600,000.00	3,600,000.00	3,600,000.00	3,600,000.00	3,600,000.00	3,600,000.00	3,600,000.00
Accrued	None	None	None	None	None	None	None
Discount	13,365.40	(10,080.60)	211,695.15	110,542.60	115,605.50	16,108.65	154,730.85
	3,613,365.40	3,589,919.40	3,811,695.15	3,710,542.60	3,715,605.50	3,616,108.65	3,754,730.85
TIC	3.164531%	3.203759%	3.212942%	3.246095%	3.260942%	3.376687%	3.418143%
NIC	1,019,882.10	1,026,668.10	1,069,104.85	1,051,821.78	1,065,057.00	1,081,752.60	1,126,069.15
Bid	(3,613,365.40)	(3,589,919.40)	(3,811,695.15)	(3,710,542.60)	(3,715,605.50)	(3,616,108.65)	(3,754,730.85)

	Bid	NIC	TIC
UMB Bank	3,613,365.40	1,019,882.10	3.164531%
Bankers' Bank	3,589,919.40	1,026,668.10	3.203759%
Hilltop	3,811,695.15	1,069,104.85	3.212942%
Robert W. Baird	3,710,542.60	1,051,821.78	3.246095%
BOK Financial	3,715,605.50	1,065,057.00	3.260942%
Northland	3,616,108.65	1,081,752.60	3.376687%
Bernardi	3,754,730.85	1,126,069.15	3.418143%

EXHIBIT "C"

CONSTRUCTION ISSUE CERTIFICATION

I, the undersigned, do hereby certify that I am the _____ of City of Washington, Iowa. I acknowledge that this Certificate is given as the basis for certain representations made in the Tax Exemption Certificate delivered by the City of Washington, State of Iowa (the "Issuer"), as of the date hereof, in connection with the issuance of \$3,600,000 General Obligation Capital Loan Notes, Series 2022, of the Issuer (the "Bonds").

The Issuer has elected to satisfy the requirements of Code Section 148(f)(4)(C)(iv)(I) based upon its reasonable expectations that more than 75% of the "available construction proceeds" of the Bonds, as defined in Section 148(f)(4)(C)(vi) of the Code, are to be used for construction expenditures with respect to property to be owned by the Issuer as a governmental unit.

Construction expenditures means capital expenditures, as defined in Regulation 1.150-1(b), that, on or before the date the property financed by the expenditures is placed in service, as defined in Regulation 1.150-2(c), will be properly chargeable to or may be capitalized as part of the basis of (1) real property, other than expenditures for the acquisition of any interest in land or real property other than land, (2) constructed personal property as defined in Regulation 1.148-7(g)(3), or (3) specially developed computer software as defined in Regulation 1.148-7(g)(4), that is functionally related and subordinate to real property or constructed personal property.

As of the date of issue of the Bonds, it is my opinion that at least 75% of the available construction proceeds of the Issue will be used for construction expenditures as defined above.

IN WITNESS WHEREOF, I hereunto affix my official signature this _____ day of _____, 2022.

CITY OF WASHINGTON, STATE OF IOWA

By: _____

Title: _____

CONTINUING DISCLOSURE CERTIFICATE

This Continuing Disclosure Certificate (the "Disclosure Certificate") is executed and delivered by the City of Washington, State of Iowa (the "Issuer"), in connection with the issuance of \$3,600,000 General Obligation Capital Loan Notes, Series 2022 (the "Notes") dated September 1, 2022. The Notes are being issued pursuant to a Resolution of the Issuer approved on August 16, 2022 (the "Resolution"). The Issuer covenants and agrees as follows:

Section 1. Purpose of the Disclosure Certificate; Interpretation. This Disclosure Certificate is being executed and delivered by the Issuer for the benefit of the Holders and Beneficial Owners of the Notes and in order to assist the Participating Underwriters in complying with S.E.C. Rule 15c2-12(b)(5). This Disclosure Certificate shall be governed by, construed and interpreted in accordance with the Rule, and, to the extent not in conflict with the Rule, the laws of the State. Nothing herein shall be interpreted to require more than required by the Rule.

Section 2. Definitions. In addition to the definitions set forth in the Resolution, which apply to any capitalized term used in this Disclosure Certificate unless otherwise defined in this Section, the following capitalized terms shall have the following meanings:

"Annual Financial Information" shall mean financial information or operating data of the type included in the final Official Statement, provided at least annually by the Issuer pursuant to, and as described in, Sections 3 and 4 of this Disclosure Certificate.

"Beneficial Owner" shall mean any person which (a) has the power, directly or indirectly, to vote or consent with respect to, or to dispose of ownership of, any Notes (including persons holding Notes through nominees, depositories or other intermediaries), or (b) is treated as the owner of any Notes for federal income tax purposes.

"Business Day" shall mean a day other than a Saturday or a Sunday or a day on which banks in Iowa are authorized or required by law to close.

"Dissemination Agent" shall mean the Issuer or any Dissemination Agent designated in writing by the Issuer and which has filed with the Issuer a written acceptance of such designation.

"Financial Obligation" shall mean a (i) debt obligation; (ii) derivative instrument entered into in connection with, or pledged as security or a source of payment for, an existing or planned debt obligation; or (iii) guarantee of (i) or (ii). The term Financial Obligation shall not include municipal securities as to which a final official statement has been provided to the MSRB consistent with S.E.C. Rule 15c2-12.

"Holders" shall mean the registered holders of the Notes, as recorded in the registration books of the Registrar.

"Listed Events" shall mean any of the events listed in Section 5(a) of this Disclosure Certificate.

"Municipal Securities Rulemaking Board" or "MSRB" shall mean the Municipal Securities Rulemaking Board, 1300 I Street NW, Suite 1000, Washington, DC 20005.

"National Repository" shall mean the MSRB's Electronic Municipal Market Access website, a/k/a "EMMA" (emma.msrb.org).

"Official Statement" shall mean the Issuer's Official Statement for the Notes, dated July 19, 2022.

"Participating Underwriter" shall mean any of the original underwriters of the Notes required to comply with the Rule in connection with offering of the Notes.

"Rule" shall mean Rule 15c2-12 adopted by the Securities and Exchange Commission (S.E.C.) under the Securities Exchange Act of 1934, and any guidance and procedures thereunder published by the S.E.C., as the same may be amended from time to time.

"State" shall mean the State of Iowa.

Section 3. Provision of Annual Financial Information.

a) The Issuer shall, or shall cause the Dissemination Agent to, not later than twelve (12) months after the end of the Issuer's fiscal year (presently June 30th), commencing with information for the 2021/2022 fiscal year, provide to the National Repository an Annual Financial Information filing consistent with the requirements of Section 4 of this Disclosure Certificate. The Annual Financial Information filing must be submitted in such format as is required by the MSRB (currently in "searchable PDF" format). The Annual Financial Information filing may be submitted as a single document or as separate documents comprising a package. The Annual Financial Information filing may cross-reference other information as provided in Section 4 of this Disclosure Certificate; provided that the audited financial statements of the Issuer may be submitted separately from the balance of the Annual Financial Information filing and later than the date required above for the filing of the Annual Financial Information if they are not available by that date. If the Issuer's fiscal year changes, it shall give notice of such change in the same manner as for a Listed Event under Section 5(c).

b) If the Issuer is unable to provide to the National Repository the Annual Financial Information by the date required in subsection (a), the Issuer shall send a notice to the Municipal Securities Rulemaking Board, if any, in substantially the form attached as Exhibit A.

c) The Dissemination Agent shall:

i. each year file Annual Financial Information with the National Repository; and

ii. (if the Dissemination Agent is other than the Issuer), file a report with the Issuer certifying that the Annual Financial Information has been filed pursuant to this Disclosure Certificate, stating the date it was filed.

Section 4. Content of Annual Financial Information. The Issuer's Annual Financial Information filing shall contain or incorporate by reference the following:

a) The last available audited financial statements of the Issuer for the prior fiscal year, prepared in accordance with generally accepted accounting principles promulgated by the Financial Accounting Standards Board as modified in accordance with the governmental accounting standards promulgated by the Governmental Accounting Standards Board or as otherwise provided under State law, as in effect from time to time, or, if and to the extent such financial statements have not been prepared in accordance with generally accepted accounting principles, noting the discrepancies therefrom and the effect thereof. If the Issuer's audited financial statements for the preceding years are not available by the time Annual Financial Information is required to be filed pursuant to Section 3(a), the Annual Financial Information filing shall contain unaudited financial statements of the type included in the final Official Statement, and the audited financial statements shall be filed in the same manner as the Annual Financial Information when they become available.

b) A table, schedule or other information prepared as of the end of the preceding fiscal year, of the type contained in the final Official Statement under the caption "Property Valuations", "Trend of Valuations", "Larger Taxpayers", "Direct Debt", "Levies and Tax Collections", and "Tax Rates".

Any or all of the items listed above may be included by specific reference to other documents, including official statements of debt issues of the Issuer or related public entities, which have been filed with the National Repository. The Issuer shall clearly identify each such other document so included by reference.

Section 5. Reporting of Significant Events.

a) Pursuant to the provisions of this Section, the Issuer shall give, or cause to be given, notice of the occurrence of any of the following events with respect to the Notes in a timely manner not later than 10 Business Days after the day of the occurrence of the event:

- i. Principal and interest payment delinquencies;
- ii. Non-payment related defaults, if material;
- iii. Unscheduled draws on debt service reserves reflecting financial difficulties;
- iv. Unscheduled draws on credit enhancements relating to the Notes reflecting financial difficulties;
- v. Substitution of credit or liquidity providers, or their failure to perform;
- vi. Adverse tax opinions, the issuance by the Internal Revenue Service of proposed or final determinations of taxability, Notices of Proposed Issue (IRS

Form 5701-TEB) or other material notices or determinations with respect to the tax-exempt status of the Series Notes, or material events affecting the tax-exempt status of the Notes;

- vii. Modifications to rights of Holders of the Notes, if material;
- viii. Note calls (excluding sinking fund mandatory redemptions), if material, and tender offers;
- ix. Defeasances of the Notes;
- x. Release, substitution, or sale of property securing repayment of the Notes, if material;
- xi. Rating changes on the Notes;
- xii. Bankruptcy, insolvency, receivership or similar event of the Issuer;
- xiii. The consummation of a merger, consolidation, or acquisition involving the Issuer or the sale of all or substantially all of the assets of the Issuer, other than in the ordinary course of business, the entry into a definitive agreement to undertake such an action or the termination of a definitive agreement relating to any such actions, other than pursuant to its terms, if material;
- xiv. Appointment of a successor or additional trustee or the change of name of a trustee, if material;
- xv. Incurrence of a Financial Obligation of the Issuer, if material, or agreement to covenants, events of default, remedies, priority rights, or other similar terms of a Financial Obligation of the Issuer, any of which affect security holders, if material; and
- xvi. Default, event of acceleration, termination event, modification of terms or other similar events under the terms of a Financial Obligation of the Issuer, any of which reflect financial difficulties.

b) Whenever the Issuer obtains the knowledge of the occurrence of a Listed Event, the Issuer shall determine if the occurrence is subject to notice only if material, and if so shall as soon as possible determine if such event would be material under applicable federal securities laws.

c) If the Issuer determines that knowledge of the occurrence of a Listed Event is not subject to materiality, or determines such occurrence is subject to materiality and would be material under applicable federal securities laws, the Issuer shall promptly, but not later than 10 Business Days after the occurrence of the event, file a notice of such occurrence with the Municipal Securities Rulemaking Board through the filing with the National Repository.

Section 6. Termination of Reporting Obligation. The Issuer's obligations under this Disclosure Certificate with respect to each Series of Notes shall terminate upon the legal defeasance, prior redemption or payment in full of all of the Notes of that Series or upon the Issuer's receipt of an opinion of nationally recognized bond counsel to the effect that, because of legislative action or final judicial action or administrative actions or proceedings, the failure of the Issuer to comply with the terms hereof will not cause Participating Underwriters to be in violation of the Rule or other applicable requirements of the Securities Exchange Act of 1934, as amended.

Section 7. Dissemination Agent. The Issuer may, from time to time, appoint or engage a Dissemination Agent to assist it in carrying out its obligations under this Disclosure Certificate, and may discharge any such Agent, with or without appointing a successor Dissemination Agent. The Dissemination Agent shall not be responsible in any manner for the content of any notice or report prepared by the Issuer pursuant to this Disclosure Certificate. The initial Dissemination Agent shall be the Issuer.

Section 8. Amendment; Waiver. Notwithstanding any other provision of this Disclosure Certificate, the Issuer may amend this Disclosure Certificate, and any provision of this Disclosure Certificate may be waived, provided that the following conditions are satisfied:

- a) If the amendment or waiver relates to the provisions of Section 3(a), 4, or 5(a), it may only be made in connection with a change in circumstances that arises from a change in legal requirements, change in law, or change in the identity, nature or status of an obligated person with respect to the Notes, or the type of business conducted;
- b) The undertaking, as amended or taking into account such waiver, would, in the opinion of nationally recognized bond counsel, have complied with the requirements of the Rule at the time of the original issuance of the Notes, after taking into account any amendments or interpretations of the Rule, as well as any change in circumstances; and
- c) The amendment or waiver either (i) is approved by the Holders of the Notes in the same manner as provided in the Resolution for amendments to the Resolution with the consent of Holders, or (ii) does not, in the opinion of nationally recognized bond counsel, materially impair the interests of the Holders or Beneficial Owners of the Notes.

In the event of any amendment or waiver of a provision of this Disclosure Certificate, the Issuer shall describe such amendment in the next Annual Financial Information filing, and shall include, as applicable, a narrative explanation of the reason for the amendment or waiver and its impact on the type (or in the case of a change of accounting principles, on the presentation) of financial information or operating data being presented by the Issuer. In addition, if the amendment relates to the accounting principles to be followed in preparing financial statements, (i) notice of such change shall be given in the same manner as for a Listed Event under Section 5(c), and (ii) the Annual Financial Information filing for the year in which the change is made will present a comparison or other discussion in narrative form (and also, if feasible, in quantitative form) describing or illustrating the material differences between the financial statements as prepared on the basis of the new accounting principles and those prepared on the basis of the former accounting principles.

Section 9. Additional Information. Nothing in this Disclosure Certificate shall be deemed to prevent the Issuer from disseminating any other information, using the means of dissemination set forth in this Disclosure Certificate or any other means of communication, or including any other information in any Annual Financial Information filing or notice of occurrence of a Listed Event, in addition to that which is required by this Disclosure Certificate. If the Issuer chooses to include any information in any Annual Financial Information filing or notice of occurrence of a Listed Event in addition to that which is specifically required by this Disclosure Certificate, the Issuer shall have no obligation under this Certificate to update such information or include it in any future Annual Financial Information filing or notice of occurrence of a Listed Event.

Section 10. Default. In the event of a failure of the Issuer to comply with any provision of this Disclosure Certificate, any Holder or Beneficial Owner of the Notes may take such actions as may be necessary and appropriate, including seeking mandate or specific performance by court order, to cause the Issuer to comply with its obligations under this Disclosure Certificate. Direct, indirect, consequential and punitive damages shall not be recoverable by any person for any default hereunder and are hereby waived to the extent permitted by law. A default under this Disclosure Certificate shall not be deemed an event of default under the Resolution, and the sole remedy under this Disclosure Certificate in the event of any failure of the Issuer to comply with this Disclosure Certificate shall be an action to compel performance.

Section 11. Duties, Immunities and Liabilities of Dissemination Agent. The Dissemination Agent shall have only such duties as are specifically set forth in this Disclosure Certificate, and the Issuer agrees to indemnify and save the Dissemination Agent, its officers, directors, employees and agents, harmless against any loss, expense and liabilities which it may incur arising out of or in the exercise or performance of its powers and duties hereunder, including the costs and expenses (including attorneys' fees) of defending against any claim of liability, but excluding liabilities due to the Dissemination Agent's negligence or willful misconduct. The obligations of the Issuer under this Section shall survive resignation or removal of the Dissemination Agent and payment of the Notes.

Section 12. Beneficiaries. This Disclosure Certificate shall inure solely to the benefit of the Issuer, the Dissemination Agent, the Participating Underwriters and Holders and Beneficial Owners from time to time of the Notes, and shall create no rights in any other person or entity.

Section 13. Rescission Rights. The Issuer hereby reserves the right to rescind this Disclosure Certificate without the consent of the Holders in the event the Rule is repealed by the S.E.C. or is ruled invalid by a federal court and the time to appeal from such decision has expired. In the event of a partial repeal or invalidation of the Rule, the Issuer hereby reserves the right to rescind those provisions of this Disclosure Certificate that were required by those parts of the Rule that are so repealed or invalidated.

Date: 1st day of September, 2022.

CITY OF WASHINGTON, STATE OF IOWA

By: _____
Mayor

ATTEST:

By: _____
City Clerk

EXHIBIT A

NOTICE TO NATIONAL REPOSITORY OF FAILURE TO FILE ANNUAL FINANCIAL INFORMATION

Name of Issuer: City of Washington, Iowa.

Name of Note Issue: \$3,600,000 General Obligation Capital Loan Notes, Series 2022

Dated Date of Issue: September 1, 2022

NOTICE IS HEREBY GIVEN that the Issuer has not provided Annual Financial Information with respect to the above-named Notes as required by Section 3 of the Continuing Disclosure Certificate delivered by the Issuer in connection with the Notes. The Issuer anticipates that the Annual Financial Information will be filed by _____.

Dated: _____ day of _____, 20__.

CITY OF WASHINGTON, STATE OF IOWA

By: _____
Its: _____



GARDEN & ASSOCIATES, LTD.

1701 3rd Avenue East, Suite 1 • P.O. Box 451 • Oskaloosa, IA 52577

Phone: 641.672.2526 • Fax: 641.672.2091

August 9, 2022

City of Washington
Deanna McCusker, City Administrator
215 E. Washington St
Washington, IA 52353

Re: NLW Subdivision – Plat 2
G&A 7021157

Dear Deanna,

Enclosed herewith are three copies of Pay Application No. 3 submitted by DeLong Construction in the amount of \$152,404.23. The application is work completed to date which includes sanitary sewer, manholes, sewer services, and stored materials.

Should the council approve, please have the pay application signed, forward one copy to DeLong Construction with payment, keep one copy for City record, and return one copy to Garden & Associates.

Contact me with any questions.

Sincerely,
GARDEN & ASSOCIATES, LTD.

Jack Pope, P.E.

Enc: Pay App #3 (3 copies)

JP/fs



ENGINEERS JOINT CONTRACTOR DOCUMENTS COMMITTEE

Contractor's Application for Payment No. 3

To (Owner):	City of Washington	Application Period:	July 10, 2022 thru August 9, 2022	Application Date:	8/9/2022
Project:	NLW Subdivision - Plat 2	From (Contractor):	Delong Construction	Via (Engineer):	Garden & Associates, Ltd.
Owner's Contract No.:		Contract:	NLW Plat 2	Contractor's Project No.:	
		Engineer's Project No.:	7021157		

Contract Working Day Summary:

Original Contract Time: _____

Added by Change Order: _____

Contract Time To Date: _____

Working Days Used to Date: _____

Working Days Remaining: _____

Approved Change Orders Number	Additions	Deductions
1		\$23,570.00
TOTALS		\$23,570.00
NET CHANGE BY CHANGE ORDERS		-\$23,570.00

- ORIGINAL CONTRACT PRICE..... \$ 3397,074.50
- Net change by Change Orders..... \$ -23,570.00
- Current Contract Price (Line 1 + 2)..... \$ 3373,504.50
- TOTAL COMPLETED AND STORED TO DATE (Column F total on Progress Estimates)..... \$ 3336,434.50
- RETAINAGE:
 - a. 5% X \$310,977.50 Work Completed..... \$ 315,548.88
 - b. 5% X \$25,457.00 Stored Material..... \$ 31,272.85
 - c. Total Retainage (Line 5a + Line 5b)..... \$ 316,821.73
- AMOUNT ELIGIBLE TO DATE (Line 4 - Line 5c)..... \$ 3319,612.78
- LESS PREVIOUS PAYMENTS (Line 6 from prior Application)..... \$ 3167,208.55
- AMOUNT DUE THIS APPLICATION..... \$ 3157,404.23
- BALANCE TO FINISH, PLUS RETAINAGE (Column G total on Progress Estimates + Line 5c above)..... \$ 2753,891.73

Contractor's Certification

The undersigned Contractor certifies, to the best of his knowledge, the following:

(1) All previous progress payments received from Owner on account of Work done under the Contract have been applied on account to discharge Contractor's legitimate obligations incurred in connection with the Work covered by prior Applications for Payment.

(2) Title to all Work, materials and equipment incorporated in said Work, or otherwise listed in or covered by this Application for Payment, will pass to Owner at time of payment free and clear of all liens, security interests, and encumbrances (except such as are covered by a bond acceptable to Owner indemnifying Owner against any such liens, security interest, or encumbrance); and

(3) All the Work covered by this Application for Payment is in accordance with the Contract Documents and is not defective.

Contractor Signature: 

Date: 8-9-22

Payment of: \$ 3157,404.23 (Line 8 or other - attach explanation of the other amount)

is recommended by:  (Engineer) 8-9-2022 (Date)

Payment of: \$ 3157,404.23 (Line 8 or other - attach explanation of the other amount)

is approved by: _____ (Owner) _____ (Date)

Contract Qty, as Adj by CO	Unit Price	Ext	Qty Complete		Qty Complete		Total Qty						
			Prior Period	Ext	This Period	Ext	Complete to date	Ext					
1	EXCAVATION, CLASS 10	3700	CY	\$	5.50	\$	20,350.00	500	\$	2,750.00	1500	\$	8,250.00
2	SUGRADE PREPARATION (12" THICK)	3515	SY	\$	1.50	\$	5,272.50	3515	\$	5,272.50	3515	\$	5,272.50
3	SUBBASE, MODIFIED	3125	SY	\$	7.20	\$	22,500.00	3125	\$	22,500.00	3125	\$	22,500.00
4	COMPACTION TESTING	1	LS	\$	3,500.00	\$	3,500.00	1	\$	3,500.00	1	\$	3,500.00
5	SUBBASE, CLASS A	390	SY	\$	8.00	\$	3,120.00		\$	-	0	\$	-
6	TRENCH FOUNDATION	50	TON	\$	25.00	\$	1,250.00		\$	-	0	\$	-
7	TRENCH COMPACTION TESTING	1	LS	\$	3,500.00	\$	3,500.00		\$	-	1	\$	3,500.00
8	SANITARY SEWER GRAVITY MAIN, TRENCHED, PVC, 8"	878	LF	\$	35.00	\$	30,730.00	858	\$	30,030.00	1	\$	3,500.00
9	SANITARY SEWER SERVICE STUB, PVC, 4"	735	LF	\$	48.00	\$	35,280.00	739	\$	35,472.00	858	\$	30,030.00
10	STORM SEWER, TRENCHED, 12"	355	LF	\$	32.00	\$	11,360.00		\$	-	120	\$	3,840.00
11	STORM SEWER, TRENCHED, RCP, 12"	270	LF	\$	42.00	\$	11,340.00		\$	-	370	\$	15,540.00
12	STORM SEWER, TRENCHED, RCP, 15"	111	LF	\$	52.00	\$	5,772.00		\$	-	104	\$	5,408.00
13	STORM SEWER, TRENCHED, 18"	55	LF	\$	50.00	\$	2,750.00		\$	-	56	\$	2,800.00
14	PIPE APRON, 12"	1	EA	\$	1,325.00	\$	1,325.00	1	\$	1,325.00	1	\$	1,325.00
15	PIPE APRON, 18"	1	EA	\$	1,450.00	\$	1,450.00	1	\$	1,450.00	1	\$	1,450.00
16	SUBDRAIN (LONGITUDINAL), 4"	1570	LF	\$	5.00	\$	7,850.00	1570	\$	7,850.00	1570	\$	7,850.00
17	SUBDRAIN (LONGITUDINAL), 4" OR 6"	10	EA	\$	275.00	\$	2,750.00		\$	-	10	\$	2,750.00
18	WATER MAIN, TRENCHED, C900 PVC, 8"	830	LF	\$	40.00	\$	33,200.00		\$	-	820	\$	32,800.00
19	WATER MAIN, TRENCHED, C900 PVC, 12"	260	LF	\$	83.00	\$	21,580.00		\$	-	160	\$	13,280.00
20	WATER SERVICE PIPE, TRENCHED, TYPE K COPPER, 1"	725	LF	\$	22.00	\$	15,950.00		\$	-	0	\$	-
21	WATER SERVICE PIPE, TRENCHLESS, TYPE K COPPER, 1"	220	LF	\$	29.00	\$	6,380.00		\$	-	0	\$	-
22	WATER SERVICE CURB STOP & BOX, 1"	25	EA	\$	500.00	\$	12,500.00		\$	-	0	\$	-
23	WATER SERVICE CURB STOP & BOX, 1"	25	EA	\$	525.00	\$	13,125.00		\$	-	0	\$	-
24	GATE VALVE 8"	1	EA	\$	1,780.00	\$	1,780.00	1	\$	1,780.00	1	\$	1,780.00
25	GATE VALVE, 12"	1	EA	\$	3,170.00	\$	3,170.00	1	\$	3,170.00	1	\$	3,170.00
26	TAPPING VALVE ASSEMBLY, 12" X 8"	1	EA	\$	4,350.00	\$	4,350.00	2	\$	8,700.00	2	\$	8,700.00
27	FIRE HYDRANT ASSEMBLY	3	EA	\$	5,405.00	\$	16,215.00	4	\$	21,620.00	4	\$	21,620.00
28	FLUSHING DEVICE (BLOWOFF)	1	EA	\$	1,500.00	\$	1,500.00	1	\$	1,500.00	1	\$	1,500.00
29	MANHOLE, SW-301, 48"	4	EA	\$	5,750.00	\$	23,000.00	3	\$	17,250.00	4	\$	23,000.00
30	MANHOLE, SW-301, 60"	0	EA	\$	-	\$	-		\$	-	0	\$	-
31	MANHOLE, SW-401, 60"	1	EA	\$	5,300.00	\$	5,300.00		\$	-	0.5	\$	2,650.00
32	INTAKE, SW-501	2	EA	\$	4,275.00	\$	8,550.00	2	\$	8,550.00	2	\$	8,550.00
33	INTAKE, SW-503	2	EA	\$	6,050.00	\$	12,100.00	2	\$	12,100.00	2	\$	12,100.00
34	EXTERNAL DROP CONNECTION	0	EA	\$	-	\$	-		\$	-	0	\$	-
35	REMOVE INTAKE	1	EA	\$	750.00	\$	750.00		\$	-	0	\$	-
36	PVC AREA DRAIN	3	EA	\$	2,550.00	\$	7,650.00		\$	-	0	\$	-
37	PAVEMENT, PCC, 7" THICK	2975	SY	\$	50.00	\$	148,750.00		\$	-	0	\$	-
38	PCC PAVEMENT SAMPLES & TESTING	1	LS	\$	3,000.00	\$	3,000.00		\$	-	0	\$	-
39	REMOVAL OF SIDEWALK	31	SY	\$	15.00	\$	465.00		\$	-	31	\$	465.00
40	SIDEWALK, PCC, 4" THICK	180	SY	\$	46.50	\$	8,370.00		\$	-	0	\$	-
41	SIDEWALK, PCC, 6" THICK	15	SY	\$	50.00	\$	750.00		\$	-	0	\$	-
42	DETECTABLE WARNINGS	28	SF	\$	40.00	\$	1,120.00		\$	-	0	\$	-

43	PAVEMENT REMOVAL	145	SY	\$	10.00	\$	1,450.00	230	\$	2,300.00	50	\$	500.00	280	\$	2,800.00
44	TEMPORARY TRAFFIC CONTROL	1	LS	\$	4,900.00	\$	4,900.00		\$	-	0.5	\$	2,450.00	0.5	\$	2,450.00
45	HYDRAULIC SEEDING, FERTILIZING & MULCHING	1	LS	\$	10,000.00	\$	10,000.00		\$	-		\$	-	0	\$	-
46	SWPPP PREPARATION	1	LS	\$	1,000.00	\$	1,000.00	1	\$	1,000.00		\$	-	1	\$	1,000.00
47	SWPPP MANAGEMENT	1	LS	\$	1,500.00	\$	1,500.00		\$	-		\$	-	0	\$	-
48	SILT FENCE	1200	LF	\$	2.00	\$	2,400.00	1000	\$	2,000.00		\$	-	1000	\$	2,000.00
49	SILT FENCE, REMOVAL OF SEDIMENT	1200	LF	\$	1.50	\$	1,800.00		\$	-		\$	-	0	\$	-
50	SILT FENCE, REMOVAL OF DEVICE	1200	LF	\$	1.50	\$	1,800.00		\$	-		\$	-	0	\$	-
51	MOBILIZATION	1	LS	\$	21,500.00	\$	21,500.00	0.5	\$	10,750.00	0.25	\$	5,375.00	0.75	\$	16,125.00
101	INTERNAL DROP CONNECTION	1	LS	\$	3,000.00	\$	3,000.00	1	\$	3,000.00		\$	-	1	\$	3,000.00
102	EXISTING MANHOLE ADJUSTMENT	1	LS	\$	3,500.00	\$	3,500.00	1	\$	3,500.00		\$	-	1	\$	3,500.00
103	CONNECTION TO EXISTING MANHOLE	1	LS	\$	1,000.00	\$	1,000.00	1	\$	1,000.00		\$	-	1	\$	1,000.00

\$	573,504.50	\$	110,552.00	\$	200,425.50	\$	310,977.50				
	Value of Completed Work:	\$	110,552.00		This Pay Est	\$	200,425.50		Total	\$	310,977.50
	Value of Materials in Storage:	\$	65,457.00			\$	(40,000.00)			\$	25,457.00
	Total:	\$	176,009.00			\$	160,425.50			\$	336,434.50



ENGINEERS JOINT CONTRACT DOCUMENTS COMMITTEE

Contractor's Application for Payment No. 8

Application Period: 7/10/22 - 8/9/22	Application Date: 8/9/2022
From (Contractor): DeLong Construction, Inc.	Via (Engineer): Garden & Associates, LTD.
Contract: West Buchanan Street Paving & Reconstruction Washington, Iowa	Engineer's Project No.: 5020201
Contractor's Project No.: STBG-SWAP-8140(612)-SG-92	

Contract Working Day Summary:

Original Contract Time: 90

Added by Change Order: 90

Contract Time To Date: 0

Working Days Used to Date: 90

Working Days Remaining: 0

Application For Payment Change Order Summary

Approved Change Orders Number	Additions	Deductions
1	\$61,871.35	\$61,871.35
2	\$12,775.00	
TOTALS	\$12,775.00	\$61,871.35
NET CHANGE BY CHANGE ORDERS	-\$49,096.35	

1. ORIGINAL CONTRACT PRICE..... \$ 1,712,167.30
2. Net change by Change Orders..... \$ -49,096.35
3. Current Contract Price (Line 1 ± 2)..... \$ 1,663,070.95
4. TOTAL COMPLETED AND STORED TO DATE (Work from Progress Estimates)..... \$ 1,507,705.55
5. RETAINAGE:
 - a. 3% X \$1,507,705.55 Work Completed..... \$ 330,000.00
 - b. 3% X Stored Material..... \$ 330,000.00
 - c. Total Retainage (Line 5.a + Line 5.b)..... \$ 660,000.00
6. AMOUNT ELIGIBLE TO DATE (Line 4 - Line 5.c)..... \$ 1,477,705.55
7. LESS PREVIOUS PAYMENTS (Line 6 from prior Application)..... \$ 893,838.81
8. AMOUNT DUE THIS APPLICATION..... \$ 583,866.74
9. BALANCE TO FINISH, PLUS RETAINAGE (Column G total on Progress Estimates + Line 5.c above)..... \$ 185,165.40

Contractor's Certification

The undersigned Contractor certifies, to the best of its knowledge, the following:

- (1) All previous progress payments received from Owner on account of Work done under the Contract have been applied on account to discharge Contractor's legitimate obligations incurred in connection with the Work covered by prior Applications for Payment;
- (2) Title to all Work, materials and equipment incorporated in said Work, or otherwise listed in or covered by this Application for Payment, will pass to Owner at time of payment free and clear of all Liens, security interests, and encumbrances (except such as are covered by a bond acceptable to Owner indemnifying Owner against any such Liens, security interest, or encumbrances); and
- (3) All the Work covered by this Application for Payment is in accordance with the Contract Documents and is not defective.

Contractor Signature: *[Signature]* Date: 8-9-22

Payment of: \$ 583,866.74 (Line 8 or other - attach explanation of the other amount)

is recommended by: *[Signature]* (Engineer) Date: 8-9-2022

Payment of: \$ 583,866.74 (Line 8 or other - attach explanation of the other amount)

is approved by: _____ (Owner) _____ (Date)

Pay Application No. 8
 West Buchanan Street Paving & Reconstruction
 Washington, Iowa
 Project Number: STBG-SWAP-8140(612)-56-92
 August 9, 2022

Delong Construction, Inc.

Item Number	Item	Item Code	Unit	Division 1		Division 2		Non-Part.		Total	Unit Price	Div. 1 Extended	Div. 2 Extended	Total
				Quantity	Total to Date	Quantity	Total to Date	Quantity	Total to Date					
1	CLEARING AND GRUBBING	2101-0959002	480							480	\$20.00	\$9,600.00		\$9,600.00
2	EXCAVATION, CLASS 13, ROADWAY AND BORROW	2102-2713070	8630							8630	\$3.95	\$34,078.50		\$34,078.50
3	TOPSOIL, STRIP, SALVAGE AND SPREAD	2105-8245815	1500							1500	\$4.50	\$6,750.00		\$6,750.00
4	SPECIAL CONSTRUCTION OF SUBGRADE	2109-8251508	28.78							28.78	\$35.00	\$1,006.30		\$1,006.30
5	MODIFIED SUBBASE	2115-8100900	1985							1985	\$39.35	\$77,745.00		\$77,745.00
6	SHOULDER FINISHING, FINISH	2113-7450920	68.47							68.47	\$7.875	\$538.00		\$538.00
7	RELOCATION OF MAIL BOXES	2213-7100400	5							5	\$50.00	\$250.00		\$250.00
8	STANDARD OR SLIP FORM PORTLAND CEMENT CONCRETE PAVEMENT, CLASS C, CLASS 3 DURABILITY, 7 IN.	2301-1030070	5260							5260	\$46.00	\$241,960.00		\$241,960.00
9	STANDARD OR SLIP FORM PORTLAND CEMENT CONCRETE PAVEMENT, CLASS C, CLASS 3 DURABILITY, 8 IN.	2301-1030080	5320							5320	\$54.35	\$289,142.00		\$289,142.00
10	PORTLAND CEMENT CONCRETE PAVEMENT SAMPLES	2301-6911222	1							1	\$1,500.00	\$1,500.00		\$1,500.00
11	GRANULAR SURFACING ON ROAD, CLASS A CURED STONE	2312-8280051	75							75	\$22.80	\$1,711.00		\$1,711.00
12	REINFORCING, AS PER PLAN	2401-0730001	1							1	\$3,000.00	\$3,000.00		\$3,000.00
13	SANITARY SEWER, SM-301, 48 IN.	2403-0330108	2							2	\$4,220.00	\$8,440.00		\$8,440.00
14	SANITARY SEWER, SM-401, 48 IN.	2403-0340108	4							4	\$3,025.00	\$12,100.00		\$12,100.00
15	STORM SEWER, SM-401, 60 IN.	2403-0340108	4							4	\$5,800.00	\$23,200.00		\$23,200.00
16	STORM SEWER, SM-401, 84 IN.	2403-0340108	1							1	\$9,745.00	\$9,745.00		\$9,745.00
17	INTAKE, SM-502, 72 IN.	2403-0250272	2							2	\$8,715.00	\$17,430.00		\$17,430.00
18	INTAKE, SM-502, 72 IN.	2403-0250270	10							10	\$3,095.00	\$30,950.00		\$30,950.00
19	INTAKE, SM-509	2403-0250900	2							2	\$5,875.00	\$11,750.00		\$11,750.00
20	INTAKE, SM-512, 24 IN.	2403-0251224	2							2	\$2,140.00	\$4,280.00		\$4,280.00
21	INTAKE, SM-512, 30 IN.	2403-0251230	1							1	\$2,395.00	\$2,395.00		\$2,395.00
22	INTAKE, SM-513	2403-0251300	1							1	\$6,220.00	\$6,220.00		\$6,220.00
23	CONNECTION TO EXISTING MANHOLE	2403-0700010	1							1	\$1,195.00	\$1,195.00		\$1,195.00
24	SUBURBAN LONGITUDINAL (SHOULDER) 4 IN. DIA.	2502-8212024	5270							5270	\$6.65	\$35,044.50		\$35,044.50
25	SUBURBAN OUTLET, DR-303	2502-8213030	32							32	\$35.00	\$1,120.00		\$1,120.00
26	STORM SEWER GRAVITY MAIN, TRENCHED, 18 IN.	2503-0110015	768							768	\$35.75	\$27,456.00		\$27,456.00
27	STORM SEWER GRAVITY MAIN, TRENCHED, 18 IN.	2503-0110010	270							270	\$40.00	\$10,800.00		\$10,800.00
28	STORM SEWER GRAVITY MAIN, TRENCHED, 24 IN.	2503-0110021	752							752	\$58.10	\$43,697.20		\$43,697.20
29	STORM SEWER GRAVITY MAIN, TRENCHED, 30 IN.	2503-0110024	238							238	\$99.40	\$23,657.20		\$23,657.20
30	STORM SEWER GRAVITY MAIN, TRENCHED, 30 IN.	2503-0110030	603							603	\$75.00	\$45,225.00		\$45,225.00
31	STORM SEWER GRAVITY MAIN, TRENCHED, 36 IN.	2503-0110035	436							436	\$101.40	\$44,250.00		\$44,250.00
32	STORM SEWER GRAVITY MAIN, TRENCHED, 42 IN.	2503-0110042	67							67	\$166.95	\$11,178.95		\$11,178.95
33	STORM SEWER GRAVITY MAIN, TRENCHED, POLYVINYL CHLORIDE PIPE (PVC), 8 IN.	2503-0112008	305							305	\$19.20	\$5,856.00		\$5,856.00
34	STORM SEWER GRAVITY MAIN, TRENCHED, REINFORCED CONCRETE PIPE (RCP), 20000 (CLASS III), 15 IN.	2503-0114215	48							48	\$47.50	\$2,280.00		\$2,280.00
35	STORM SEWER GRAVITY MAIN, TRENCHED, REINFORCED CONCRETE PIPE (RCP), 20000 (CLASS III), 18 IN.	2503-0114218	27							27	\$58.95	\$1,591.65		\$1,591.65
36	STORM SEWER GRAVITY MAIN, TRENCHED, POLYVINYL CHLORIDE PIPE (PVC), 8 IN.	2503-0200030	536							536	\$15.50	\$8,208.00		\$8,208.00
37	SANITARY SEWER GRAVITY MAIN, TRENCHED, POLYVINYL CHLORIDE PIPE (PVC), 8 IN.	2504-0134008	1236							1236	\$41.30	\$51,268.80		\$51,268.80
38	SANITARY SEWER SERVICE STUD, POLYVINYL CHLORIDE PIPE (PVC), 6 IN.	2504-0200040	300							300	\$35.00	\$10,500.00		\$10,500.00
39	SANITARY SEWER CLEANOUT, SM-403	2504-0200042	2							2	\$1,447.00	\$2,894.00		\$2,894.00
40	REINFORCEMENT, CLASS D	2507-8000042	125							125	\$43.00	\$5,375.00		\$5,375.00
41	EROSION STONE	2507-8020000	6							6	\$95.00	\$570.00		\$570.00
42	REMOVAL OF PAVEMENT	2510-0735530	2230							2230	\$3.00	\$6,690.00		\$6,690.00
43	REMOVAL OF INKAS AND UTILITY ACCESSES	2510-0735530	6							6	\$40.00	\$240.00		\$240.00
44	SIDWALK, P.C. CONCRETE, 5 IN.	2511-7526005	33							33	\$48.00	\$1,584.00		\$1,584.00
45	SIDWALK, P.C. CONCRETE, 6 IN.	2511-7526006	16							16	\$35.00	\$560.00		\$560.00
46	DETECTABLE MARKINGS	2511-7528101	418							418	\$51.20	\$21,501.60		\$21,501.60
47	CONCRETE, 6 IN.	2515-6745000	395							395	\$8.00	\$3,160.00		\$3,160.00
48	REMOVAL OF PAVED DRIVEWAY	2516-6525008	128							128	\$0.00	\$0.00		\$0.00
49	COMBINED CONCRETE SIDEWALK AND RETAINING WALL	2516-6525008	138							138	\$0.00	\$0.00		\$0.00
50	REMOVAL AND REINSTALLATION OF FENCE, FIELD	2518-4200040	280							280	\$4.50	\$1,260.00		\$1,260.00
51	SAFETY CLOSURE	2520-2510000	35							35	\$52.50	\$1,837.50		\$1,837.50
52	TRAFFIC CONTROL	2520-8445110	3							3	\$150.00	\$450.00		\$450.00
53	MOBILIZATION	2523-4900005	0.6							0.6	\$80.00	\$48.00		\$48.00
54	TRENCH FOUNDATION	2525-0000210	0.4							0.4	\$60.00	\$24.00		\$24.00
55	TRENCH COMPACTION TESTING	2525-0000300	50							50	\$3.00	\$150.00		\$150.00
56	POLYVINYL CHLORIDE PIPE (PVC), 8 IN.	2552-0114008	40							40	\$66.40	\$2,656.00		\$2,656.00
57	TRENCHED, POLYVINYL CHLORIDE PIPE (PVC), 12 IN.	2552-0114012	2120							2120	\$14.20	\$30,104.00		\$30,104.00
58	COPPER, 2 IN.	2552-0205120	1							1	\$3,215.00	\$3,215.00		\$3,215.00
59	COPPER, 1 IN.	2554-0205110	25							25	\$61.00	\$1,525.00		\$1,525.00
60	COPPER, 1 IN.	2554-0205110	5							5	\$390.00	\$1,950.00		\$1,950.00
61	VALVE, GATE, 12 IN.	2554-0207008	2							2	\$2,100.00	\$4,200.00		\$4,200.00
62	VALVE, GATE, 12 IN.	2554-0207012	5							5	\$3,350.00	\$16,750.00		\$16,750.00

Pay Application No. 8
West Buchanan Street Paving & Reconstruction
Washington, Iowa

DeLong Construction, Inc.

Project Number:	2554-0210201	FIRE HYDRANT ASSEMBLY, MW-201
63	2599-9999903	(CLERIC YARDS' ITEM) MEDIAN LANDSCAPE CONCRETE
64	2599-9999905	(EACH ITEM) APRON 36 IN.
65	2599-9999905	(EACH ITEM) APRON 42 IN.
66	2599-9999905	(EACH ITEM) REMOVAL OF EXISTING HYDRANT ASSEMBLY
67	2599-9999909	(EACH ITEM) WATER MAIN CONNECTIONS
68	2599-9999909	(EACH ITEM) REPAIR DAMAGED TILE 4 IN. OR 6 IN.
69	2599-9999909	(EACH ITEM) REPAIR DAMAGED TILE 4 IN. OR 6 IN.
70	2599-9999909	(EACH ITEM) REPAIR DAMAGED TILE 4 IN. OR 6 IN.
71	2599-9999909	(EACH ITEM) REPAIR DAMAGED TILE 4 IN. OR 6 IN.
72	2599-9999909	(EACH ITEM) REPAIR DAMAGED TILE 4 IN. OR 6 IN.
73	2599-9999909	(EACH ITEM) REPAIR DAMAGED TILE 4 IN. OR 6 IN.
74	2599-9999909	(EACH ITEM) REPAIR DAMAGED TILE 4 IN. OR 6 IN.
75	2599-9999909	(EACH ITEM) REPAIR DAMAGED TILE 4 IN. OR 6 IN.
76	2599-9999909	(EACH ITEM) REPAIR DAMAGED TILE 4 IN. OR 6 IN.
77	2599-9999909	(EACH ITEM) REPAIR DAMAGED TILE 4 IN. OR 6 IN.
78	2599-9999909	(EACH ITEM) REPAIR DAMAGED TILE 4 IN. OR 6 IN.

Unit	Quantity	Unit Price	Total	Div. 1	Div. 2	Total
EACH	6	\$3,200.00	\$19,200.00			\$19,200.00
CT	0	\$1,810.00	\$0.00			\$0.00
EACH	1	\$2,650.00	\$2,650.00			\$2,650.00
EACH	1	\$3,500.00	\$3,500.00			\$3,500.00
EACH	1	\$550.00	\$550.00			\$550.00
LF	3	\$1,010.00	\$3,030.00			\$3,030.00
LF	3	\$20.00	\$60.00			\$60.00
LF	500	\$15.00	\$7,500.00			\$7,500.00
TON	1	\$500.00	\$500.00			\$500.00
ACRE	6	\$4,076.56	\$24,459.36			\$24,459.36
ACRE	5	\$700.00	\$3,500.00			\$3,500.00
ACRE	1	\$1,000.00	\$1,000.00			\$1,000.00
LF	3000	\$1,500.00	\$4,500.00			\$4,500.00
LF	3000	\$2.50	\$7,500.00			\$7,500.00
EACH	3	\$2.00	\$6.00			\$6.00
EACH	2	\$1.00	\$2.00			\$2.00
LF	1	\$1,500.00	\$1,500.00			\$1,500.00
LS	1	\$1,000.00	\$1,000.00			\$1,000.00
Totals			\$1,186,282.79	\$321,422.80	\$1,507,705.55	

Category	Amount
Eligible Amount	\$1,186,282.79
Less: IDOT Withholding 5%	(\$59,314.14)
Subtotal This Request	\$1,126,968.65
Less: Previously Reimbursed	(\$56,411.38)
Amount to Be Reimbursed This Application	\$570,557.27



GARDEN & ASSOCIATES, LTD.

1701 3rd Avenue East, Suite 1 • P.O. Box 451 • Oskaloosa, IA 52577

Phone: 641.672.2526 • Fax: 641.672.2091

August 10, 2022

City of Washington
Deanna McCusker, City Administrator
215 E. Washington St
Washington, IA 52353

Re: East Adams Street Reconstruction
Washington, Iowa - 2022
G&A 5019061

Dear Deanna;

Enclosed herewith are three copies of Pay Application No. 1 submitted by Cornerstone Excavating, Inc. in the amount of \$174,383.90. The application is for work completed to date which includes water main, water services, and storm sewer.

Should the council approve, please have the pay application signed, forward one copy to Cornerstone Excavating, Inc. with payment, keep one copy for City record, and return one copy to Garden & Associates.

If there are any questions, please contact me at (641) 672-2526.

Sincerely,
GARDEN & ASSOCIATES, LTD.

Jack Pope, P.E.

Enc: Pay Application 1 (3 copies)

JP/fs

ENGINEERS AND SURVEYORS

OSKALOOSA IOWA

CRESTON IOWA

CONTINUATION SHEET AIA DOCUMENT G703

AIA Document G702, APPLICATION AND CERTIFICATE FOR PAYMENT.
 containing Contractor's signed Certification is attached.
 In tabulations below, amounts are stated to the nearest dollar.
 Use column 1 on Contracts where variable retainage for line items may apply.

Adams Street Reconstruction
 WAS021

APPLICATION NO: 1
 APPLICATION DATE: 8/9/2022
 PERIOD TO: 7/31/2022
 ARCHITECT'S PROJECT NO:

ITEM NO.	DESCRIPTION OF WORK	SCHEDULED VALUE			WORK COMPLETED		THIS PERIOD		MATERIALS PRESENTLY STORED (NOT IN D OR E)	TOTAL COMPLETED AND STORED TO DATE (D+E+F)	% (G/C)	BALANCE TO FINISH (C-G)	RETAINAGE 5%
		QTY	UNIT	UNIT \$	TOTAL \$	QTY	UNIT \$	QTY					
1	Cleaning and Grubbing	1	LS	\$7,500.00	\$7,500.00	-	\$0.00	1	\$7,500.00	100%	\$0.00	\$375.00	
2	Excavation, Class 10	3,900	CY	\$17.00	\$66,300.00	-	\$0.00	-	\$0.00	100%	\$66,300.00	\$0.00	
3	Subgrade Preparation (12" Thick)	9,810	SY	\$1.60	\$15,696.00	-	\$0.00	-	\$0.00	100%	\$15,696.00	\$0.00	
4	Subbase, Modified	9,810	SY	\$7.50	\$73,575.00	-	\$0.00	-	\$0.00	100%	\$73,575.00	\$0.00	
5	Compaction Testing	1	ILS	\$5,500.00	\$5,500.00	-	\$0.00	-	\$0.00	100%	\$5,500.00	\$0.00	
6	Trench Foundation	50	TON	\$33.00	\$1,650.00	-	\$0.00	-	\$0.00	100%	\$1,650.00	\$0.00	
7	Trench Compaction Testing (Water Main and Storm Sewer)	1	LS	\$8,000.00	\$8,000.00	-	\$0.00	-	\$0.00	100%	\$8,000.00	\$0.00	
8	Storm Sewer Trenched, PVC, 8"	20	LF	\$46.50	\$930.00	-	\$0.00	-	\$0.00	100%	\$930.00	\$0.00	
9	Storm Sewer Trenched, 12"	36	LF	\$2,070.00	\$2,070.00	-	\$0.00	-	\$0.00	100%	\$2,070.00	\$0.00	
10	Storm Sewer Trenched, 15"	607	LF	\$58.00	\$35,813.00	-	\$0.00	28	\$1,652.00	5%	\$34,161.00	\$82.60	
11	Storm Sewer Trenched, 18"	88	LF	\$64.00	\$5,632.00	-	\$0.00	-	\$0.00	100%	\$5,632.00	\$0.00	
12	Storm Sewer, Trenched, 24"	50	LF	\$83.00	\$4,150.00	-	\$0.00	-	\$0.00	100%	\$4,150.00	\$0.00	
13	Removal of Storm Sewer, All Types, 5 24"	885	LF	\$17.50	\$15,487.50	-	\$0.00	-	\$0.00	100%	\$15,487.50	\$0.00	
14	Subdrain (Longitudinal), 4"	5,005	LF	\$10.65	\$53,303.25	-	\$0.00	-	\$0.00	100%	\$53,303.25	\$0.00	
15	Subdrain Outlets and Connections, 4" or 6"	25	EA	\$250.00	\$6,250.00	-	\$0.00	-	\$0.00	100%	\$6,250.00	\$0.00	
16	Storm Sewer Service Stub, PVC, 4"	200	LF	\$37.50	\$7,500.00	-	\$0.00	-	\$0.00	100%	\$7,500.00	\$0.00	
17	Water Main, Trenched, PVC, 4"	20	LF	\$93.00	\$1,860.00	-	\$0.00	3	\$93.00	15%	\$527.00	\$4.85	
18	Water Main Trenched, PVC, 6"	35	LF	\$43.00	\$1,505.00	-	\$0.00	42	\$1,806.00	120%	(\$301.00)	\$90.30	
19	Water Main Trenched, PVC, 8"	1,550	LF	\$45.00	\$69,750.00	-	\$0.00	1,041	\$46,845.00	67%	\$22,905.00	\$2,342.25	
20	Water Main, Trenchless, RJ (Restrained Joint) DIP, 8"	120	LF	\$150.00	\$18,000.00	-	\$0.00	-	\$0.00	100%	\$18,000.00	\$0.00	
21	Water Service Pipe, Type K Copper, 1"	300	LF	\$31.75	\$9,525.00	-	\$0.00	188	\$5,905.50	62%	\$3,619.50	\$285.28	
22	Water Service Corporation, 1"	8	EA	\$325.00	\$2,600.00	-	\$0.00	7	\$2,275.00	88%	\$325.00	\$113.75	
23	Water Service Curb Stop and Box, 1"	8	EA	\$400.00	\$3,200.00	-	\$0.00	6	\$2,400.00	75%	\$800.00	\$120.00	
24	Gate Valve, 4"	1	EA	\$1,250.00	\$1,250.00	-	\$0.00	1	\$1,250.00	100%	\$0.00	\$62.50	
25	Gate Valve, 8"	6	EA	\$1,900.00	\$11,400.00	-	\$0.00	6	\$11,400.00	100%	\$0.00	\$570.00	
26	Tapping Valve Assembly, 4" x 4"	1	EA	\$3,550.00	\$3,550.00	-	\$0.00	-	\$0.00	100%	\$3,550.00	\$0.00	
27	Tapping Valve Assembly, 12" x 8"	1	EA	\$4,800.00	\$4,800.00	-	\$0.00	1	\$4,800.00	100%	\$0.00	\$240.00	
28	Fire Hydrant Assembly	5	EA	\$5,750.00	\$28,750.00	-	\$0.00	5	\$28,750.00	100%	\$0.00	\$1,437.50	
29	Fire Hydrant Assembly Removal	3	EA	\$1,500.00	\$4,500.00	-	\$0.00	2	\$3,000.00	67%	\$1,500.00	\$150.00	
30	Valve Box Removal	4	EA	\$600.00	\$2,400.00	-	\$0.00	1	\$600.00	25%	\$1,800.00	\$30.00	
31	Water Main Connection No. 1	1	LS	\$3,950.00	\$3,950.00	-	\$0.00	1	\$3,950.00	100%	\$0.00	\$197.50	
32	Water Main Connection No. 2	1	LS	\$3,950.00	\$3,950.00	-	\$0.00	1	\$3,950.00	100%	\$0.00	\$197.50	
33	Water Main Connection No. 3	1	LS	\$3,950.00	\$3,950.00	-	\$0.00	1	\$3,950.00	100%	\$0.00	\$197.50	
34	Water Main Connection No. 4	1	LS	\$4,150.00	\$4,150.00	-	\$0.00	1	\$4,150.00	100%	\$0.00	\$207.50	
35	Water Main Connection No. 5	1	LS	\$3,550.00	\$3,550.00	-	\$0.00	1	\$3,550.00	100%	\$0.00	\$177.50	
36	Water Main Connection No. 6	1	LS	\$3,050.00	\$3,050.00	-	\$0.00	1	\$3,050.00	100%	\$0.00	\$152.50	
37	Water Main Connection No. 7	1	LS	\$3,050.00	\$3,050.00	-	\$0.00	-	\$0.00	100%	\$0.00	\$0.00	
38	Lower Existing Water Main	1	EA	\$4,800.00	\$4,800.00	-	\$0.00	-	\$0.00	100%	\$0.00	\$0.00	
39	Manhole, SW-401, 48" Dia.	1	EA	\$3,900.00	\$3,900.00	-	\$0.00	-	\$0.00	100%	\$0.00	\$0.00	
40	Manhole, SW-401, 50" Dia.	1	EA	\$9,100.00	\$9,100.00	-	\$0.00	-	\$0.00	100%	\$0.00	\$0.00	

CONTINUATION SHEET AIA DOCUMENT G703

AIA Document G702, APPLICATION AND CERTIFICATE FOR PAYMENT, containing Contractor's signed Certification is attached. In tabulators below, amounts are stated to the nearest dollar. Use column 1 on Contracts where variable retainage for line items may apply.

Adams Street Reconstruction
WASD21

APPLICATION NO: 1
MAY/2022
PERIOD TO: 7/31/2022
ARCHITECT'S PROJECT NO:

ITEM NO.	DESCRIPTION OF WORK	SCHEDULED VALUE			WORK COMPLETED		THIS PERIOD		MATERIALS PRESENTLY STORED (NOT IN DORE)	TOTAL COMPLETED AND STORED TO DATE (D+E+F)	% (G/C)	BALANCE TO FINISH (C-G)	RETAINAGE 5%
		QTY	UNIT	UNIT \$	TOTAL \$	QTY	TOTAL \$	QTY					
41	Manhole, SW-402, 4' x 6'	1	EA	\$13,650.00	\$13,650.00	-	\$0.00	-	\$0.00	-	\$13,650.00	\$0.00	
42	Inlet, SW-501	6	EA	\$4,625.00	\$27,750.00	-	\$0.00	0.50	\$2,312.50	-	\$25,437.50	\$115.63	
43	Inlet, SW-502, 48" Dia.	1	EA	\$4,775.00	\$4,775.00	-	\$0.00	-	\$0.00	-	\$4,775.00	\$0.00	
44	Inlet, SW-503	2	EA	\$5,975.00	\$11,950.00	-	\$0.00	-	\$0.00	-	\$11,950.00	\$0.00	
45	Inlet, SW-503, Modified	1	EA	\$11,900.00	\$11,900.00	-	\$0.00	1	\$11,900.00	-	\$0.00	\$595.00	
46	Inlet, SW-504, Modified	2	EA	\$7,250.00	\$14,500.00	-	\$0.00	-	\$0.00	-	\$14,500.00	\$0.00	
47	Inlet, SW-512, Case 1, 18" Riser	2	EA	\$2,800.00	\$5,600.00	-	\$0.00	-	\$0.00	-	\$5,600.00	\$0.00	
48	Manhole Adjustment, Minor	14	EA	\$2,100.00	\$29,400.00	-	\$0.00	-	\$0.00	-	\$29,400.00	\$0.00	
49	Inlet Adjustment, Minor	1	EA	\$1,350.00	\$1,350.00	-	\$0.00	-	\$0.00	-	\$1,350.00	\$0.00	
50	Connection to Existing Manhole	2	EA	\$2,950.00	\$5,900.00	-	\$0.00	-	\$0.00	-	\$5,900.00	\$0.00	
51	Remove Manhole	3	EA	\$2,500.00	\$7,500.00	-	\$0.00	-	\$0.00	-	\$7,500.00	\$0.00	
52	Remove Inlet	4	EA	\$2,500.00	\$10,000.00	-	\$0.00	-	\$0.00	-	\$10,000.00	\$0.00	
53	Connection to Existing RCAP	1	EA	\$2,700.00	\$2,700.00	-	\$0.00	-	\$0.00	-	\$2,700.00	\$0.00	
54	Pavement, PCC, 7" Thick	8,750	SY	\$54.00	\$472,500.00	-	\$0.00	-	\$0.00	-	\$472,500.00	\$0.00	
55	PCC Pavement Samples and Testing	1	LS	\$4,750.00	\$4,750.00	-	\$0.00	-	\$0.00	-	\$4,750.00	\$0.00	
56	Removal of Sidewalk	25	SY	\$25.00	\$625.00	-	\$0.00	-	\$0.00	-	\$625.00	\$0.00	
57	Removal of Driveway	407	SY	\$15.00	\$6,105.00	-	\$0.00	-	\$0.00	-	\$6,105.00	\$0.00	
58	Removal of Curb	7	LF	\$105.00	\$735.00	-	\$0.00	-	\$0.00	-	\$735.00	\$0.00	
59	Sidewalk, PCC, 4" Thick	703	SY	\$62.00	\$43,586.00	-	\$0.00	-	\$0.00	-	\$43,586.00	\$0.00	
60	Sidewalk, PCC, 6" Thick	871	SY	\$69.00	\$60,099.00	-	\$0.00	-	\$0.00	-	\$60,099.00	\$0.00	
61	Detectable Warnings	134	SF	\$62.00	\$8,308.00	-	\$0.00	-	\$0.00	-	\$8,308.00	\$0.00	
62	Driveway, Paved, PCC, 6" Thick	654	SY	\$74.50	\$48,723.00	-	\$0.00	-	\$0.00	-	\$48,723.00	\$0.00	
63	Driveway, Granular (Class 'A' Crushed Stone, IDOT Gradation No. 11)	5	TON	\$40.00	\$200.00	-	\$0.00	-	\$0.00	-	\$200.00	\$0.00	
64	Pavement Removal	5,402	SY	\$6.00	\$32,412.00	-	\$0.00	-	\$0.00	-	\$32,412.00	\$0.00	
65	Temporary Traffic Control	1	LS	\$7,000.00	\$7,000.00	-	\$0.00	-	\$0.00	-	\$7,000.00	\$0.00	
66	Hydraulic Seeding, Seeding, Fertilizing, and Mulching	1	LS	\$14,500.00	\$14,500.00	-	\$0.00	-	\$0.00	-	\$14,500.00	\$0.00	
67	SWPPP Preparation	1	LS	\$2,250.00	\$2,250.00	-	\$0.00	1	\$2,250.00	-	\$0.00	\$112.50	
68	SWPPP Management	1	LS	\$4,000.00	\$4,000.00	-	\$0.00	0.50	\$2,000.00	-	\$2,000.00	\$100.00	
69	Silt Fence	1,000	LF	\$1.20	\$1,200.00	-	\$0.00	290	\$348.00	-	\$852.00	\$17.40	
70	Silt Fence, Removal of Sediment	1,000	LF	\$0.10	\$100.00	-	\$0.00	-	\$0.00	-	\$100.00	\$0.00	
71	Silt Fence, Removal of Device	1,000	LF	\$0.10	\$100.00	-	\$0.00	-	\$0.00	-	\$100.00	\$0.00	
72	Mobilization	1	LS	\$95,500.00	\$95,500.00	-	\$0.00	0.25	\$23,875.00	-	\$71,625.00	\$1,193.75	
TOTALS				\$1,463,694.75	\$1,463,694.75		\$0.00		\$183,562.00		\$1,280,132.75	\$9,178.10	
CHANGE ORDERS													
0		0		\$0.00	\$0.00		\$0.00		\$0.00		\$0.00	\$0.00	
0		0		\$0.00	\$0.00		\$0.00		\$0.00		\$0.00	\$0.00	
0		0		\$0.00	\$0.00		\$0.00		\$0.00		\$0.00	\$0.00	
0		0		\$0.00	\$0.00		\$0.00		\$0.00		\$0.00	\$0.00	
0		0		\$0.00	\$0.00		\$0.00		\$0.00		\$0.00	\$0.00	
0		0		\$0.00	\$0.00		\$0.00		\$0.00		\$0.00	\$0.00	
TOTAL CHANGE ORDERS				\$0.00	\$0.00		\$0.00		\$0.00		\$0.00	\$0.00	
TOTALS & CHANGE ORDERS				\$1,463,694.75	\$1,463,694.75		\$0.00		\$183,562.00		\$1,280,132.75	\$9,178.10	

ORDINANCE NO. _____

**AN ORDINANCE AMENDING THE MUNICIPAL CODE OF THE
CITY OF WASHINGTON, IOWA, BY AMENDING
CHAPTER 70 TRAFFIC CODE ENFORCEMENT PROCEDURES**

BE IT ORDAINED by the City Council that the Code of Ordinances of the City of Washington, Iowa be amended as follows:

SECTION 1. Amend. 70.03 “Parking Violations: Alternate.” is amended as follows:

Uncontested violations of parking restrictions imposed by this Code of Ordinances shall be charged upon a simple notice of a fine payable at the Police Department. The fine for each violation charged under a simple notice of a fine shall be in the amount of \$25.00 for all violations except improper use of a persons with disabilities parking permit or as specified in each subsection. The fine for improper use of a persons with disabilities parking permit is \$100.00. If such fine is not paid within thirty (30) days, it shall be increased by \$5.00. Failure to pay the notice is grounds for filing of a complaint in District Court.

Contested parking violations will be filed with the District Court as City Ordinance Violations. Violations filed in District Court shall, upon conviction, be subject to a fine as listed in Chapter 1.14 of this Code of Ordinances.

As an alternative to filing unpaid notices in District Court, the city may follow an alternate procedure. The City of Washington will provide a written notice to all owners of vehicles with unpaid parking violations that are more than 30 days old indicating the total amount due, including the \$5 late charge.

If no response or payment is made by the vehicle owner after ninety (90) days of issuance, the city may use an alternate method:

- A. Provide a list of the owner’s name, driver’s license or social security number, and the license plate numbers for all such unpaid fines to the Washington County Treasurer. The Treasurer will enter a “stop” on the registered owner(s) in the Iowa DOT system and refuse to renew the registration of any vehicle on which the individual is an owner, lessee, or primary operator pursuant to the authority of Iowa Code Section 321.40 and 321.236. (Code of Iowa, Sec. 321.236[1b] & 321L.4[2]). OR
- B. For persons with more than \$50 in unpaid fines, the city may provide the owner’s name and social security number and amount owed to the State of Iowa Department of Administrative Services Offset Program.

SECTION 2. Amend. 70.06 “Impounding Vehicles” is amended as follows:

A peace officer is hereby authorized to remove, or cause to be removed, a vehicle from a street, public alley, public parking lot or highway to the nearest garage or other place of safety, or to a garage designated or maintained by the City, under the circumstances hereinafter enumerated:

1. Disabled Vehicle. When a vehicle is so disabled as to constitute an obstruction to traffic and the person or persons in charge of the vehicle are by reason of physical injury incapacitated to such an extent as to be unable to provide for its custody or removal. (Code of Iowa, Sec. 321.236[1]).

2. Illegally Parked Vehicle. When any vehicle is left unattended and is so illegally parked as to constitute a definite hazard or obstruction to the normal movement of traffic. (Code of Iowa, Sec. 321.236[1])

3. Snow Removal. When any vehicle is left parked in violation of a ban on parking during snow removal operations.

4. Parked Over Limited Time Period. When any vehicle is left parked for a continuous period in violation of any limited parking time and the vehicle has been tagged with a warning notice of towing. If the owner can be located, the owner may be given an opportunity to remove the vehicle, or the vehicle shall be towed. (Code of Iowa, Sec. 321.236[1])

5. Junk Vehicle. When a vehicle meets the definition of a junk vehicle as defined in City Ordinance Chapter 51 or the vehicle has one or more flat tires and has been parked or standing for more than 24 hours.

6. Costs. In addition to the standard penalties provided, the owner or driver of any vehicle impounded for the violation of any of the provisions of this chapter shall be required to pay the reasonable cost of towing and storage. (Code of Iowa, Sec. 321.236[1])

SECTION 3. Repealer. All ordinances or parts of ordinances in conflict with the provisions of this Ordinance are hereby repealed.

SECTION 4. Severability. If any section, provision or part of this ordinance shall be judged invalid or unconstitutional such adjudication shall not affect the validity of the ordinance as a whole or any section, provision or part thereof not adjudged invalid or unconstitutional.

SECTION 5. Effective Date. This Ordinance shall be in effect after its final passage, approval and publication as provided by law.

Passed and approved this _____ day of _____, 2022.

Jaron P. Rosien, Mayor

Attest:

Sally Y. Hart, City Clerk

Approved on First Reading: July 19, 2022

Approved on Second Reading: August 2, 2022

Approved on Third & Final Reading: _____

I certify that the foregoing was published as Ordinance No. _____ on the _____ day of _____, 2022.

City Clerk

ORDINANCE NO. _____

**AN ORDINANCE AMENDING THE MUNICIPAL CODE OF THE
CITY OF WASHINGTON, IOWA, BY AMENDING
CHAPTER 69 PARKING REGULATIONS**

BE IT ORDAINED by the City Council that the Code of Ordinances of the City of Washington, Iowa be amended as follows:

SECTION 1. Amend. Section 69.08 “No Parking Zones” the following paragraphs are amended as follows:

- 35.** South Fourth Avenue, on the west side of the street between East Madison and East Van Buren from 7:30 a.m. to 4:00 p.m. on school days.
- 36.** South Fourth Avenue on the east side, beginning at a point 200 feet south of the centerline of East Monroe Street and extending south to a point 200 feet south of the centerline of East Jackson Street, from 7:30 a.m. to 4:00 p.m. on school days.
- 37.** South Fourth Avenue, on the east side, from Jefferson Street to Washington Street.
- 38.** South Fourth Avenue, on the west side from East Washington Street to East Jefferson Street, from 7:30 a.m. to 4:00 p.m. on school days.
- 48.** East Van Buren Street, on the south side, from South Seventh Avenue to 300 feet east of the intersection with South Tenth Avenue.
- 49.** East Van Buren Street, on the south side, for a distance of 63 feet west from its intersection with Fourth Avenue.
- 50.** East Van Buren Street, on both sides, for a distance of 145 feet east of the centerline of South Iowa Avenue.
- 92.** South Sixth Avenue, on the east side between East Monroe Street and East Van Buren Street from 7:30 a.m. to 4:00 p.m. on school days.

SECTION 2. Add Paragraphs. Section 69.08 “No Parking Zones” the following new paragraphs are added as follows:

102. South Avenue C, on the west side for 100 feet north from the centerline with West Madison Street.

107. East Third Street, on the south side for 70 feet east from the centerline with North Iowa Avenue.

108. West Third Street, on the south side for 70 feet west from the centerline with North Iowa Avenue.

109. West Third Street, on the south side for 70 feet east from the centerline with North Marion Avenue.

110. North Iowa Avenue, on the east side for 50 feet south from the centerline with Third Street.

111. North Iowa Avenue, on the west side for 50 feet south from the centerline with Third Street.

112. North Avenue D, on both sides for 70 feet south from the centerline with West Sixth Street.

113. North Avenue D, on both sides for 70 feet north from the centerline with West Sixth.

115. Campbell Drive, on the inside curb from the intersection with Country Club Road to the cul-de-sac.

116. Green Meadows Drive on the west and south sides of the street from its intersection with West Madison Street to its intersection with West Main Street.

117. North Iowa Avenue, on the east side for 50 feet south from the centerline with Second Street.

118. North Iowa Avenue, on the west side for 50 feet south from the centerline with Second Street.

119. East Tyler Street, on the north side between South Sixth Avenue and Circle Drive.

SECTION 3. Repealer. All ordinances or parts of ordinances in conflict with the provisions of this Ordinance are hereby repealed.

SECTION 4. Severability. If any section, provision or part of this ordinance shall be judged invalid or unconstitutional such adjudication shall not affect the validity of the ordinance as a whole or any section, provision or part thereof not adjudged invalid or unconstitutional.

SECTION 5. Effective Date. This Ordinance shall be in effect after its final passage, approval and publication as provided by law.

Passed and approved this _____ day of _____, 2022.

Jaron P. Rosien, Mayor

Attest:

Sally Y. Hart, City Clerk

Approved on First Reading: August 2, 2022

Approved on Second Reading: _____

Approved on Third & Final Reading: _____

I certify that the foregoing was published as Ordinance No. _____ on the _____ day of _____, 2022.

City Clerk

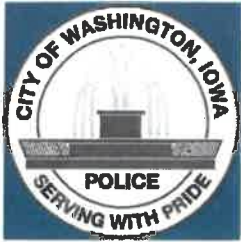

Washington Police Department

James Lester, Chief of Police

215 East Washington Street

Washington, Iowa 52353

Phone: 319-653-2256 Dispatch: 319-653-2107

Rhonda Hill
Administrative Assistant

August 11, 2022

Lyle Hansen
Lieutenant

To: Mayor and City Council

Cc: City Administrator Deanna McCusker and City Clerk Sally Hart

Shamus Altenhofen
Lieutenant

Ref.: Parking and Streets Regulation Ordinances

Jason Chalupa
Sergeant

Benjamin Altenhofen
Sergeant

Based on direction from the August 2 City Council meeting the attached Ordinances are presented for your consideration and approval of first reading.

Brian VanWilligen
Investigator

As requested by Council, the language relating to campers and motor homes has been removed from the proposed changes to the Truck Parking Ordinance (69.10) and Snow Ban / Snow Emergency (69.12 and 69.13) is included based on consensus from the Council Workshop at the last meeting.

Eric Kephart
K-9 Handler

Seth Adam
Police Officer

Aaron Kephart
Police Officer

Respectfully,

Tanner Lavelly
Police Officer

Jim Lester
Chief of Police

Christopher Raymer
Police Officer

Mia Brdecka
Police Officer

ORDINANCE NO. _____

**AN ORDINANCE AMENDING THE MUNICIPAL CODE OF THE
CITY OF WASHINGTON, IOWA, BY AMENDING
CHAPTER 69 PARKING REGULATIONS**

BE IT ORDAINED by the City Council that the Code of Ordinances of the City of Washington, Iowa be amended as follows:

SECTION 1. Add Paragraph. A new Section 69.06 “Parking Prohibited” Paragraph 19 is added as follows: “No Parking Zones. No person shall park a vehicle adjacent to any curb or in any area of the public right-of-way that has been painted yellow or where official signs are posted prohibiting parking.”

SECTION 2. Amend. 69.10 Truck Parking Limited is amended as follows:
(Code of Iowa, Sec. 321.236[1]) (321.1)

1. No person shall park or leave standing any commercial vehicle, motor truck, truck tractor, trailer, or semi-trailer on any street, avenue, or boulevard in the City between the time of sunset and sunrise. The provisions of this subsection do not apply to light delivery trucks, pickup trucks or pickup trucks that are part of a combination vehicle that is less than forty (40) feet in total length.

2. No person shall park any truck or van on the west side of B Avenue from the intersection of Washington Street to the first alley south of said intersection.

SECTION 3. Repeal. Paragraph 69.12 One Vehicle, One Hour Parking is hereby repealed.

SECTION 4. Repeal. Sections 69.14 Snow Routes, 69.16 Reserved Parking and 69.18 Preferred Student Parking Space are hereby repealed.

SECTION 5. Repealer. All ordinances or parts of ordinances in conflict with the provisions of this Ordinance are hereby repealed.

SECTION 6. Severability. If any section, provision or part of this ordinance shall be judged invalid or unconstitutional such adjudication shall not affect the validity of the ordinance as a whole or any section, provision or part thereof not adjudged invalid or unconstitutional.

SECTION 7. Effective Date. This Ordinance shall be in effect after its final passage, approval and publication as provided by law.

Passed and approved this ____ day of _____, 2022.

Jaron P. Rosien, Mayor

Attest:

Sally Y. Hart, City Clerk

Approved on First Reading: _____

Approved on Second Reading: _____

Approved on Third & Final Reading: _____

I certify that the foregoing was published as Ordinance No. _____ on the _____ day
of _____, 2022.

City Clerk

ORDINANCE NO. _____

**AN ORDINANCE AMENDING THE MUNICIPAL CODE OF THE
CITY OF WASHINGTON, IOWA, BY AMENDING
CHAPTER 69 PARKING REGULATIONS**

BE IT ORDAINED by the City Council that the Code of Ordinances of the City of Washington, Iowa be amended as follows:

SECTION 1. Add Paragraph 69.12 Snow Ban Parking:

The following parking regulations shall be in effect from November 1 to April 1 to allow for the safe initiation and completion of ice and snow removal operations.

No vehicle shall be left parked, abandoned, or unattended on any street or alley in the City during snow removal operations, or before such operations have removed or cleared accumulated snow or ice from the street to each curb edge or shoulder.

Snow Ban Parking does not apply within the area of the public square and extending one block each way there from, said area bounded by the south line of Second Street, the west line of Second Avenue, the north line of Jefferson Street, and the east line of Avenue B, including Second Street, Second Avenue, Jefferson Street and Avenue B, during normal business hours of eight o'clock (8:00) A.M. to six o'clock (6:00) P.M. and during normal weekend, evening, or holiday hours.

The fine for each violation of this subsection shall be \$50 with contested and unpaid violations handled as provided for in Section 70.03 of these Ordinances.

SECTION 2. Amend. Paragraph 69.13 Snow Emergency is amended as follows:

Upon the Mayor's declaration of a Snow Emergency, persons shall comply with the following:

A. Residential Areas:

No person shall park, abandon, or leave unattended any vehicle on any public street or alley unless the snow has been removed or plowed from the street to each curb edge or alley and the snow has ceased to fall.

B. Downtown Area:

From 10pm to 6am when signs are posted in the northwest and southeast corners of Central Park no vehicles shall park within the area of the public square and extending one block each way there from, said area bounded

by the south line of Second Street, the west line of Second Avenue, the north line of Jefferson Street, and the east line of Avenue B, but not including any portion of Second Street, Second Avenue, Jefferson Street or Avenue B.

The foregoing prohibition shall not apply to the above-described areas during normal business hours of eight o'clock (8:00) A.M. to six o'clock (6:00) P.M. and during normal weekend, evening, or holiday hours.

A Snow Emergency shall continue from its proclamation through the duration of the snow or ice storm and the forty-eight (48) hour period after cessation of such storm, except as above provided on streets that have had snow completely cleared to the curb edge or at a time otherwise declared by the Mayor.

Such a ban shall be of uniform in application and the Police Chief is directed to publicize the requirements widely, using all available news media, in early November each year.

Where predictions or occurrences indicate the need, the Mayor, may proclaim a snow emergency and the Police Chief shall inform the news media and publicize the proclamation and the parking rules thereunder. Such emergency may be extended or shortened when conditions warrant.

The fine for each violation of this subsection shall be \$50 with contested and unpaid violations handled as provided for in Section 70.03 of these Ordinances.

SECTION 3. Repeal. Sections 69.14 Snow Routes, 69.16 Reserved Parking and 69.18 Preferred Student Parking Space are hereby repealed.

SECTION 4. Repealer. All ordinances or parts of ordinances in conflict with the provisions of this Ordinance are hereby repealed.

SECTION 5. Severability. If any section, provision or part of this ordinance shall be judged invalid or unconstitutional such adjudication shall not affect the validity of the ordinance as a whole or any section, provision or part thereof not adjudged invalid or unconstitutional.

SECTION 6. Effective Date. This Ordinance shall be in effect after its final passage, approval and publication as provided by law.

Passed and approved this _____ day of _____, 2022.

Jaron P. Rosien, Mayor

Attest:

Sally Y. Hart, City Clerk

Approved on First Reading: _____
Approved on Second Reading: _____
Approved on Third & Final Reading: _____

I certify that the foregoing was published as Ordinance No. _____ on the _____ day of _____, 2022.

City Clerk