



AGENDA OF THE REGULAR SESSION OF THE  
COUNCIL OF THE CITY OF WASHINGTON, IA  
TO BE HELD IN THE  
**WASTEWATER TREATMENT PLANT**  
**1065 WEST BUCHANAN STREET**  
AT 4:30 P.M. TUESDAY, May 16, 2023  
and  
**COUNCIL CHAMBERS**  
**215 E. WASHINGTON STREET**  
AT 6:00 P.M., TUESDAY, May 16, 2023

*To attend the meeting via Zoom go to:*

<https://us02web.zoom.us/j/84413261389?pwd=Sy9VMjgldHpoYkkwTzFPTy84aUF2dz09>

*Meeting ID: 844 1326 1389*

*Passcode: 6536584*

**Call to Order**

**Pledge of Allegiance**

**Roll call**

Agenda for the Regular Session to be held at 6:00 P.M., Tuesday, May 16<sup>th</sup>, 2023 to be approved as proposed or amended.

**Consent:**

1. Council Minutes May 2, 2023
2. FEH Design, Public Library Makerspace Professional Services, \$12,314.91
3. Iowa Finance Authority, SRF Loan, Water Treatment Plant, Principal, Interest & Fee, \$12,990.00
4. Iowa Finance Authority, SRF Loan, Additional Water Treatment Plan, Principal, Interest & Fee, \$231,360.00
5. Iowa Finance Authority, SRF Loan, Wastewater Treatment Plant, Principal, Interest & Fee, \$555,917.50
6. Iowa Finance Authority, SRF Loan, Westside Interceptor Project, Principal, Interest & Fee, \$104,750.00
7. Iowa Pump Works, Pump Number 2 Repair Wastewater Treatment Plant, \$11,539.40
8. Platte River Displays, Inc., July 4, 2023 Fireworks Show, \$9,600.00
9. Schneider Geospatial, Beacon Setup, On Site GIS Consulting, Professional Services, \$9,200.00
10. SRF Consulting Group, Quiet Zone Study, \$520.00
11. Hy-Vee Wine and Spirits, 528 Iowa Highway 1, Class E Retail Alcohol License

- (Permanent Premise Transfer Application - Amendment)
12. 2 BROS MEXICAN BAR & GRILL, INC., 331 North 4<sup>th</sup> Avenue, Class C Retail Alcohol License **(new)**
  13. Hy-Vee Food Store, 528 South Highway 1, Over-the-Counter, Cigarettes/Tobacco/Alternative Nicotine Products/Vapor Products **(renewal)**
  14. Hy-Vee Fast & Fresh, 520 South Highway 1, Over-the-Counter, Cigarettes/Tobacco/Alternative Nicotine Products/Vapor Products **(renewal)**
  15. Walmart #1475, 2485 Highway 92, Over-the-Counter, Cigarettes/Tobacco/Alternative Nicotine Products **(renewal)**
  16. BP One Trip, 1504 East Washington Street, Over-the-Counter, Cigarettes/Tobacco/Vapor Products **(renewal)**
  17. Fareway Stores, Inc. #554, 301 North Marion Avenue, Over-the-Counter, Cigarettes/Tobacco/Alternative Nicotine Products/Vapor Products **(renewal)**
  18. Washington Liquor and Tobacco Outlet, 304 West Madison Street, Over-the-Counter, Cigarettes/Tobacco/Alternative Nicotine Products, Vapor Products **(renewal)**
  19. Wine & Spirits, 106 West 2<sup>nd</sup> Street, Over-the-Counter, Delivery, Cigarettes/Tobacco/Alternative Nicotine Products/Vapor Products **(renewal)**
  20. Casey's General Store #1624, 1002 W. Madison St., Over-the-Counter, Cigarettes/Tobacco/Alternative Nicotine Products/Vapor Products **(renewal)**
  21. Casey's General Store #3528, 1730 E. Washington St., Over-the-Counter, Cigarettes/Tobacco/Alternative Nicotine Products/Vapor Products **(renewal)**
  22. The Tippy Traveler's LLC, 107 West 2<sup>nd</sup> Street, Special Class C Retail Alcohol License Five-Day (May 17-22)
  23. Department Reports

**PRESENTATION FROM THE PUBLIC** – Please limit comments to 3 Minutes

**CLAIMS & FINANCIALS**

- Claims for May 16, 2023
- April 2023 Financial Report

**NEW BUSINESS**

1. Discussion and Consideration of 12th and Highway 92 Plans
2. Discussion of PLANT Washington
3. Discussion and Consideration of a Resolution Approving Final Plat for the Wiley Subdivision Fourth Addition Near Pizza Ranch
4. Discussion and Consideration of Alley in 200 Block of Marion Ave. to S. Avenue B
5. Discussion and Consideration of a Resolution Amending Certain Charges and Fees for the Elm Grove and Woodlawn Cemeteries
6. Discussion and Consideration of a Resolution Authorizing Tax Abatement Under the Washington Urban Revitalization Plan for Washington, Iowa (501 S. 15<sup>th</sup> Avenue)
7. Discussion and Consideration of a Resolution Approving a Temporary Mayor Pro Tem Appointment for the City of Washington
8. Discussion and Consideration of a Resolution Adopting a Code of Ethics for Elected

## Officials

9. Discussion and Consideration of a Resolution Approving a Mowing Maintenance Agreement with WCHS for Mowing Services for Lot 7
10. Discussion and Consideration of a Resolution Determining the Necessity and Setting Dates of a Consultation and a Public Hearing on a Proposed Washington East Commercial Urban Renewal Plan for a Proposed Urban Renewal Area in the City of Washington, State of Iowa
11. Discussion and Consideration of the Washington Police Department Updated Fee Schedule
12. Discussion and Consideration of Change Order No. 3 for West Buchanan Street Paving and Reconstruction Project (DeLong Construction, Inc. \$51,261.59)
13. Discussion and Consideration of Pay Application No. 12 for West Buchanan Street Paving and Reconstruction Project (DeLong Construction, Inc. \$16,777.34)
14. Discussion and Consideration of Pay Application No. 1 for 2022 Washington Water Main Improvements (Cornerstone Excavating, Inc. \$145,606.50)
15. Discussion and Consideration of First Reading of an Ordinance Amending Utility Rates

## **OLD BUSINESS**

1. Discussion and Consideration of a Resolution Authorizing Tax Abatement Under the Washington Urban Revitalization Plan for Washington, Iowa (6 Circle Drive) (*tabled*)
2. Discussion and Consideration and Possible First Reading of Ordinance No 2023- Vacant Building Code (*tabled*)

## **CLOSED SESSION**

- Closed Session per Iowa Code 21.5(1)(i) – To evaluate the professional competency of an individual whose appointment, hiring, performance, or discharge is being considered when necessary to prevent needless and irreparable injury to that individual's reputation and that individual requests a closed session.

## **DEPARTMENTAL REPORTS**

Police Department  
City Attorney  
City Administrator

## **MAYOR & COUNCILPERSONS**

Millie Youngquist, Mayor Pro Tem  
Illa Earnest  
Bethany Glinsmann  
Elaine Moore  
Ivan Rangel  
Fran Stigers

## **ADJOURNMENT**

CITY OF WASHINGTON  
Council Minutes 5-2-2023

The Council of the City of Washington, Iowa, met in Regular Session in the Council Chambers, 215 East Washington Street on Tuesday, May 2, 2023, at 6:00 p.m. Mayor Pro Tem Youngquist in the chair.

On roll call present: Earnest, Glinsmann, Moore, Rangel, Stigers and Youngquist. Absent: none.

Motion by Glinsmann, seconded by Moore, that the agenda for the Regular Session to be held at 6:00 p.m., Tuesday, May 2, 2023, be approved. Motion carried.

Consent:

1. Council Minutes April 18, 2023
2. East Central Iowa Housing Trust Fund, Local Match Toward the Old Main Facility Project, \$30,000.00
3. FOX Strand Associates, 2021 Washington Water Main Improvements Final Design, \$3,460.00
4. FOX Strand Associates, Downtown Streetscape Study, \$1,075.00
5. FOX Strand Associates, Biosolids Land Application Plan Update, \$5,000.00
6. Garden & Associates, Ltd., Buchanan Street Paving Project, \$3,213.00
7. Garden & Associates, Ltd., Reconstruction of Adams Street, \$3,284.54
8. Gronewold, Bell, Kyhnn & Co. P.C., Audit of Financial Statements for the Year Ended June 30, 2022, \$1,509.98
9. Kevin Olson City Attorney, February and March Legal Services, \$2,412.30
10. UMB, General Obligation Capital Loan Notes Series 2015, \$121,162.50
11. UMB, General Obligation Refunding Bonds Series 2016A, \$161,285.00
12. UMB, General Obligation Refunding Bonds Series 2016B, \$55,431.25
13. UMB, General Obligation Capital Loan Notes Series 2018A, \$327,535.00
14. UMB, LOSST Revenue Bonds Series 2018B, \$129,595.00
15. UMB, General Obligation Capital Loan Notes Series 2020A, \$173,250.00
16. UMB, Taxable General Obligation Capital Loan Notes Series 2020B, \$137,700.00
17. UMB, General Obligation Capital Loan Notes Series 2022, \$179,847.50
18. Veenstra & Kimm, Inc., 2023 Seal Coat Project, \$630.00
19. Veenstra & Kimm, Inc., 12<sup>th</sup> Avenue and Washington Street Intersection Improvements, \$2,171.00
20. Veenstra & Kimm, Inc., Dog Park Storm Sewer, \$542.71
21. Washington County Jail, 2185 Lexington Boulevard, Alternative Nicotine Products, Over-the-Counter (new)
22. Department Reports

Motion by Moore, seconded by Stigers, to approve consent items 1-22. Motion carried.

Code Enforcement Officer Elaine Jennings presented the monthly nuisance update.

Main Street Washington Director Samantha Meyer presented a special event request for 2023 Movies on Main to be held June 2, July 7, August 4, and October 7. Motion by Earnest, seconded by Moore, to approve the Movies on Main special event request. Motion carried.

Michael York with American Legion Post 29 presented a special event request for Memorial

Day Observance in Central Park to be held May 29, 2023. Motion by Moore, seconded by Rangel, to approve the American Legion Post 29 Memorial Day special event request. Motion carried.

Kathy Salazar presented an updated 2023 Farmers Market special event request to include parking for three mobile food vendors each week. Motion by Stigers, seconded by Glinsmann, to approve the updated 2023 Farmers Market special event request. Motion carried.

Motion by Glinsmann, seconded by Earnest, to approve the Home Girl Realty Alive After Five on May 23 special event request. Motion carried.

Presentation from the public: none.

Claims for May 2, 2023 were presented by Finance Director Kelsey Brown.

Motion by Stigers, seconded by Moore, to approve claims for May 2, 2023. Motion carried.

Motion by Moore, seconded by Stigers, to open the public hearing for Fiscal Year 2023 Budget Amendment No. 2. Roll call on the motion: Ayes: Earnest, Glinsmann, Moore, Rangel, Stigers, and Youngquist. Nays: none. Motion carried.

No oral or written objections were received.

Motion by Moore, seconded by Glinsmann, to close the public hearing. Roll call on the motion: Ayes: Earnest, Glinsmann, Moore, Rangel, Stigers, and Youngquist. Nays: none. Motion carried.

Motion by Earnest, seconded by Rangel, to approve a Resolution to Approving Fiscal Year 2023 Budget Amendment No. 2. Roll call on the motion: Ayes: Earnest, Glinsmann, Moore, Rangel, Stigers, and Youngquist. Nays: none. Motion carried. **(Resolution 2023-033)**

Motion by Moore, seconded by Glinsmann, to open the public hearing for 2023 Sealcoat Project. Roll call on the motion: Ayes: Earnest, Glinsmann, Moore, Rangel, Stigers, and Youngquist. Nays: none. Motion carried.

No oral or written objections were received.

Motion by Glinsmann, seconded by Rangel, to close the public hearing. Roll call on the motion: Ayes: Earnest, Glinsmann, Moore, Rangel, Stigers, and Youngquist. Nays: none. Motion carried.

Motion by Glinsmann, seconded by Moore, to approve a Resolution Adopting Plans, Specifications, Form of Contract, and Estimate of Costs for 2023 Sealcoat Project. Roll call on the motion: Ayes: Earnest, Glinsmann, Moore, Rangel, Stigers, and Youngquist. Nays: none. Motion carried. **(Resolution 2023-034)**

Sealcoat 2023 Bids Received:

- LL Pelling Co. Inc. \$101,291.90

Motion by Glinsmann, seconded by Rangel, to approve a Resolution Awarding 2023 Sealcoat Project to LL Pelling Co. Inc. for \$101,291.90. Roll call on the motion: Ayes: Earnest, Glinsmann, Moore, Rangel, Stigers, and Youngquist. Nays: none. Motion carried. **(Resolution 2023-035)**

After discussion, motion by Stigers, seconded by Earnest, to table a Resolution Authorizing Tax Abatement Under the Washington Urban Revitalization Plan for Washington, Iowa (6 Circle Drive). Roll call on the motion: Ayes: Earnest, Glinsmann, Moore, Rangel, Stigers, and Youngquist. Nays: none. Motion carried.

Meyer presented two Downtown Investment Grant recommendations.

Motion by Earnest, seconded by Rangel, to approve a Resolution Endorsing a Downtown Investment Grant Agreement with Greiner Buildings, Inc. at 120 E. Main Street for \$50,000. Roll call on the motion: Ayes: Earnest, Glinsmann, Moore, Rangel, Stigers, and Youngquist. Nays: none. Motion carried. **(Resolution 2023-036)**

Motion by Glinsmann, seconded by Stigers, to approve a Resolution Endorsing a Downtown Investment Grant Agreement with AHECO Holdings at 106 South Iowa Avenue for \$50,000. Roll call on the motion: Ayes: Earnest, Glinsmann, Moore, Rangel, Stigers, and Youngquist. Nays: none. Motion carried. **(Resolution 2023-037)**

Motion by Stigers, seconded by Glinsmann, to approve a Resolution Authorizing Levy, Assessment, and Collection of Costs to the Washington County Treasurer. Roll call on the motion: Ayes: Earnest, Glinsmann, Moore, Rangel, Stigers, and Youngquist. Nays: none. Motion carried. **(Resolution 2023-038)**

Motion by Earnest, seconded by Stigers, to approve a Resolution Approving Entering Into an Engagement Agreement with Ahlers & Cooney, P.C. to Develop a New Urban Renewal Area and a Development Agreement with DW Developments, LLC. Roll call on the motion: Ayes: Earnest, Glinsmann, Moore, Rangel, Stigers, and Youngquist. Nays: none. Motion carried. **(Resolution 2023-039)**

Motion by Glinsmann, seconded by Moore, to approve Pay Application No. 5 to DeLong Construction for \$126,543.93 for Country Club View Subdivision. Motion carried.

No action was taken on possible first reading of Ordinance No. 2023 – Vacant Building Code and it remains tabled.

The City Council went into workshop to discuss the preliminary Fiscal Year 2024-2028 Capital Improvement Plan update. City Administrator Deanna McCusker introduced the update. The City Council discussed the plan and projects. The City Council requested it be reviewed by staff and brought back to a council meeting in June.

Department reports were presented.

Motion by Stigers, seconded by Glinsmann, that the Regular Session held at 6:00 p.m., Tuesday, May 2, 2023, is adjourned at 7:19 p.m. Motion passed unanimously.

Sally Y. Hart, City Clerk

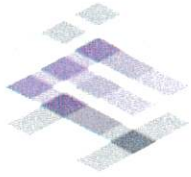

# FEH DESIGN

604 EAST GRAND AVENUE  
DES MOINES, IOWA 50309  
P 515 288 2000

WWW.FEHDESIGN.COM

Washington Public Library  
Cary Ann Siegfried  
115 W. Washington St.  
Washington, IA 52352

Invoice number 113407  
Date 04/30/2023

Project **2023202 Washington Public Library  
Makerspace**

### Invoice Summary

Description	Amount Not to Exceed	Prior Billed	Remaining	Current Billed
<b>Professional Services</b>	69,500.00	6,450.00	50,735.09	12,314.91
<b>Total</b>	69,500.00	6,450.00	50,735.09	12,314.91

### PROFESSIONAL SERVICES

#### Professional Fees

	Hours	Rate	Billed Amount
Project Architect 3	33.00	110.00	3,630.00
Interior Design Principal	47.00	125.00	5,875.00

#### Reimbursable Expenses

	Billed Amount
Meals	44.11
Miles	235.80

#### Consultant

570  
 001-6-4010 6490  
 Initials ad  
 EXP. design fees  
 Vender# \_\_\_\_\_  
 Date Rec. 4/30/23  
 Due Date 5/30/23  
 Inv# 113407

Engineering Consultant  
KCL Engineering LLC

Billed Amount

2,530.00

Invoice total **12,314.91**



Iowa Finance Authority  
 1963 Bell Avenue, Suite 200  
 Des Moines, IA 50315

Telephone: 515.452.0400  
 Fax: 877.461.0904

**City of Washington**  
**Attn: City Clerk**  
**215 E Washington Street**  
**Washington IA 52353**

**LOAN STATEMENT**

<i>Statement Date</i>	5/1/2023
<i>Loan Number:</i>	D0544R
<i>Original Loan Amount</i>	\$219,000.00
<i>Current Loan Balance:</i>	\$199,000.00
<i>Interest Rate:</i>	1.75%
<i>Annual Service Fee Rate</i>	0.25%
<b>Payment Due Date:</b>	<b>6/1/2023</b>
<b>Current Principal Due:</b>	<b>\$11,000.00</b>
<i>Prior Principal Due</i>	\$0.00
<i>Current Interest Due:</i>	\$1,741.25
<i>Prior Interest Due</i>	\$0.00
<i>Service Fee Due:</i>	\$248.75
<b>Total Amount Due:</b>	<b>\$12,990.00</b>

**Do not pay.** The total amount due will be automatically deducted from your bank account on the payment due date.

If your banking information has changed, please complete an ACH Authorization form and fax it to us at 877.461.0904 at least one week before your payment is due (download a form from <http://www.iowafinanceauthority.gov/ach>.)

Questions? Please contact Becky Wu at 800-432-7230 or [Becky.Wu@IowaFinance.com](mailto:Becky.Wu@IowaFinance.com)

Keep upper portion for your records

D0544R





Iowa Finance Authority  
 1963 Bell Avenue, Suite 200  
 Des Moines, IA 50315

Telephone: 515.452.0400  
 Fax: 877.461.0904

City of Washington  
 Attn: City Clerk  
 215 E Washington Street  
 Washington IA 52353

**LOAN STATEMENT**

Statement Date	5/1/2023
Loan Number:	D0431R
Original Loan Amount	\$4,378,000.00
Current Loan Balance:	\$3,636,000.00
Interest Rate:	1.75%
Annual Service Fee Rate	0.25%
<b>Payment Due Date:</b>	<b>6/1/2023</b>
Current Principal Due:	\$195,000.00
Prior Principal Due	\$0.00
Current Interest Due:	\$31,815.00
Prior Interest Due	\$0.00
Service Fee Due:	\$4,545.00
<b>Total Amount Due:</b>	<b>\$231,360.00</b>

**Do not pay.** The total amount due will be automatically deducted from your bank account on the payment due date.

If your banking information has changed, please complete an ACH Authorization form and fax it to us at 877.461.0904 at least one week before your payment is due (download a form from <http://www.iowafinanceauthority.gov/ach>.)

Questions? Please contact Becky Wu at 800-432-7230 or [Becky.Wu@IowaFinance.com](mailto:Becky.Wu@IowaFinance.com)

Keep upper portion for your records

D0431R



Iowa Finance Authority  
 1963 Bell Avenue, Suite 200  
 Des Moines, IA 50315

**LOAN STATEMENT**

Telephone: 515.452.0400  
 Fax: 877.461.0904

*Statement Date* 5/1/2023  
*Loan Number:* CF0412R  
*Original Loan Amount* \$16,316,000.00  
*Current Loan Balance:* \$10,926,000.00  
*Interest Rate:* 1.75%  
*Annual Service Fee Rate* 0.25%

**City of Washington**  
**Attn: City Clerk**  
**215 E Washington Street**  
**Washington IA 52353**

**Payment Due Date:** **6/1/2023**  
**Current Principal Due:** \$433,000.00  
**Prior Principal Due** \$0.00  
**Current Interest Due:** \$95,602.50  
**Prior Interest Due** \$0.00  
**Service Fee Due:** \$27,315.00  
**Total Amount Due:** **\$555,917.50**

**Do not pay.** The total amount due will be automatically deducted from your bank account on the payment due date.

If your banking information has changed, please complete an ACH Authorization form and fax it to us at 877.461.0904 at least one week before your payment is due (download a form from <http://www.iowafinanceauthority.gov/ach>.)

Questions? Please contact Becky Wu at 800-432-7230 or [Becky.Wu@IowaFinance.com](mailto:Becky.Wu@IowaFinance.com)

Keep upper portion for your records

CF0412R



Iowa Finance Authority  
 1963 Bell Avenue, Suite 200  
 Des Moines, IA 50315



Telephone: 515.452.0400  
 Fax: 877.461.0904

**City of Washington**  
**Attn: City Clerk**  
**215 E Washington Street**  
**Washington IA 52353**

**LOAN STATEMENT**

<i>Statement Date</i>	5/1/2023
<i>Loan Number:</i>	C0441R
<i>Original Loan Amount</i>	\$3,000,000.00
<i>Current Loan Balance:</i>	\$2,200,000.00
<i>Interest Rate:</i>	1.75%
<i>Annual Service Fee Rate</i>	0.25%
<b>Payment Due Date:</b>	<b>6/1/2023</b>
<i>Current Principal Due:</i>	\$80,000.00
<i>Prior Principal Due</i>	\$0.00
<i>Current Interest Due:</i>	\$19,250.00
<i>Prior Interest Due</i>	\$0.00
<i>Service Fee Due:</i>	\$5,500.00
<b>Total Amount Due:</b>	<b>\$104,750.00</b>

**Do not pay.** The total amount due will be automatically deducted from your bank account on the payment due date.

If your banking information has changed, please complete an ACH Authorization form and fax it to us at 877.461.0904 at least one week before your payment is due (download a form from <http://www.iowafinanceauthority.gov/ach>.)

Questions? Please contact Becky Wu at 800-432-7230 or [Becky.Wu@IowaFinance.com](mailto:Becky.Wu@IowaFinance.com)

Keep upper portion for your records

C0441R

Jaron P. Rosien, Mayor  
Deanna McCusker, City  
Administrator  
Kelsey Brown, Finance Director  
Sally Hart, City Clerk  
Kevin Olson, City Attorney



**City of Washington**  
215 East Washington Street  
Washington, Iowa 52353  
(319) 653-6584 Phone  
(319) 653-5273 Fax

---

WWTP MEMORANDUM

---

TO: CITY COUNCIL, MAYOR, AND CITY ADMINISTRATOR

FROM: JASON WHISLER WASTE WATER SUPERINTENDENT

SUBJECT: WEST EQ (EQUALIZATION BASIN)

DATE: THURSDAY MAY 11, 2023

DURING OUR ANNUAL SERVICE AND INSPECTION PUMP NUMBER 2 AT THE WEST EQ. BASIN HAD MOISTURE IN THE MOTOR, WHICH INDICATES A SEAL IS FAILING. I'M ASKING FOR APPROVAL FOR THE REPAIR OF \$11,539.40 MONEY AVAILABLE FOR IN ACCOUNT 610-6-8015-6350 PLEASE SEE ATTACHED QUOTE FOR SCOPE OF WORK.

IF YOU HAVE ANY QUESTIONS OR NEED ADDITIONAL INFORMATION, PLEASE LET ME KNOW.

THANK YOU

JASON WHISLER



Quote  
 #QTE003631  
 05/10/2023

Iowa Pump Works, Inc.  
 825 SW Ordinance Rd  
 Ankeny, IA 50023

**Bill To**  
 Washington IA WWTP, City of  
 PO Box 516  
 Washington IA 52353  
 United States  
 Phone:

**Ship To**  
 Washington IA WWTP, City of  
 1065 W Buchanan St  
 Washington IA 52353  
 United States

**Details**

Shop repair of FLOWSERVE 8MSX15AW SER # 11M00288 MOTOR MODEL# M25-6-230/460 25 HP 1160RPM 3PH 230/460V ;  
 \*\*Anything outside of the below scope of work, will be re-quoted and approved prior to completion of work ; Lead Time:  
 10-12 Weeks - Lead times are only an estimate and cannot be guaranteed due to the nationwide supply chain issues

<b>Prepared By</b>	<b>Phone</b>	<b>Email</b>
Jesse Gildea	855-228-6383	<a href="mailto:info@iowapumpworks.com">info@iowapumpworks.com</a>

<b>Sales Rep</b>	<b>Expires</b>	<b>Terms</b>
Michael Hoffmann	05/20/2023	Net 30

Item	Comment	QTY	Rate	Amount
23427 QUOTE ITEM	Shop repair of FLOWSERVE 8MSX15AW SER # 11M00288 - To Include: Mechanical Seals, Bearings, O-Ring Kit, Terminal Board, Cable Gland Bushing, Impeller Key, Retaining Ring, Moisture Sensor, Machine Work (Spray/Polish Shaft), Outside Services (Wash/Bake Stator), Misc Shop Supplied, Oil/Environmental Charges, & Shop Labor	1	\$11,539.40	\$11,539.40

**Subtotal** \$11,539.40

**Total** \$11,539.40

*Pricing is valid for 10 days and does not include freight charges or applicable taxes.*

**Items quoted for repair and leftover 30 days, without a decision to repair, will be discarded.**

Signature: \_\_\_\_\_ Date: \_\_\_\_\_

Thank you for your business.  
 Toll Free: 855-228-6383 | Email: [info@iowapumpworks.com](mailto:info@iowapumpworks.com) | Website: <http://www.iowapumpworks.com>



PLATTE RIVER DISPLAYS, INC.



P.O. BOX 65  
DICKEYVILLE, WI. 53808  
563-590-7945  
[platteriverdisplays@live.com](mailto:platteriverdisplays@live.com)

City of Washington

This year's fireworks show will be \$9600.00

Date of show 7/4/2023

Please make out checks out to...

Platte River Displays, Inc.	\$6000.00
Platte River Pyros, LLC.	\$3,600.00
Insurance included	
<b>Total</b>	<b>\$9,600.00</b>

Thank you,  
Platte River Displays Inc.  
John Fowler



# CERTIFICATE OF LIABILITY INSURANCE

DATE (MM/DD/YYYY)

5/30/2022

THIS CERTIFICATE IS ISSUED AS A MATTER OF INFORMATION ONLY AND CONFERS NO RIGHTS UPON THE CERTIFICATE HOLDER. THIS CERTIFICATE DOES NOT AFFIRMATIVELY OR NEGATIVELY AMEND, EXTEND OR ALTER THE COVERAGE AFFORDED BY THE POLICIES BELOW. THIS CERTIFICATE OF INSURANCE DOES NOT CONSTITUTE A CONTRACT BETWEEN THE ISSUING INSURER(S), AUTHORIZED REPRESENTATIVE OR PRODUCER, AND THE CERTIFICATE HOLDER.

**IMPORTANT:** If the certificate holder is an ADDITIONAL INSURED, the policy(ies) must be endorsed. If SUBROGATION IS WAIVED, subject to the terms and conditions of the policy, certain policies may require an endorsement. A statement on this certificate does not confer rights to the certificate holder in lieu of such endorsement(s).

<b>PRODUCER</b> Ryder Rosacker McCue & Huston (MGD by Hull & Company) 509 W Koenig St Grand Island NE 68801	<b>CONTACT NAME:</b> Kristy Wolfe			
	<b>PHONE (A/G, No, Ext):</b> 308-382-2330 <b>FAX (A/G, No):</b> 308-382-7109 <b>E-MAIL ADDRESS:</b> Kwolfe@ryderinsurance.com			
<b>INSURED</b> Platte River Displays Inc. PO Box 65 Dickeyville WI 53808	<b>INSURER(S) AFFORDING COVERAGE</b>		<b>NAIC #</b>	
	INSURER A : SCOTTSDALE INS CO		41297	
	INSURER B :			
	INSURER C :			
	INSURER D :			
	INSURER E :			
INSURER F :				

**COVERAGES**                                      **CERTIFICATE NUMBER: 771829021**                                      **REVISION NUMBER:**

THIS IS TO CERTIFY THAT THE POLICIES OF INSURANCE LISTED BELOW HAVE BEEN ISSUED TO THE INSURED NAMED ABOVE FOR THE POLICY PERIOD INDICATED. NOTWITHSTANDING ANY REQUIREMENT, TERM OR CONDITION OF ANY CONTRACT OR OTHER DOCUMENT WITH RESPECT TO WHICH THIS CERTIFICATE MAY BE ISSUED OR MAY PERTAIN, THE INSURANCE AFFORDED BY THE POLICIES DESCRIBED HEREIN IS SUBJECT TO ALL THE TERMS, EXCLUSIONS AND CONDITIONS OF SUCH POLICIES. LIMITS SHOWN MAY HAVE BEEN REDUCED BY PAID CLAIMS.

INSR LTR	TYPE OF INSURANCE	ADDL SUBR INSR WVD	POLICY NUMBER	POLICY EFF (MM/DD/YYYY)	POLICY EXP (MM/DD/YYYY)	LIMITS
A	<b>GENERAL LIABILITY</b> <input checked="" type="checkbox"/> COMMERCIAL GENERAL LIABILITY <input type="checkbox"/> CLAIMS-MADE <input checked="" type="checkbox"/> OCCUR GEN'L AGGREGATE LIMIT APPLIES PER: <input checked="" type="checkbox"/> POLICY <input type="checkbox"/> PRO-JECT <input type="checkbox"/> LOC		CPS4019618	5/14/2022	5/14/2023	EACH OCCURRENCE \$ 1,000,000 DAMAGE TO RENTED PREMISES (Ea occurrence) \$ 100,000 MED EXP (Any one person) \$ 5,000 PERSONAL & ADV INJURY \$ 1,000,000 GENERAL AGGREGATE \$ 2,000,000 PRODUCTS - COMP/OP AGG \$ 2,000,000 \$
	<b>AUTOMOBILE LIABILITY</b> <input type="checkbox"/> ANY AUTO <input type="checkbox"/> ALL OWNED AUTOS <input type="checkbox"/> HIRED AUTOS <input type="checkbox"/> SCHEDULED AUTOS <input type="checkbox"/> NON-OWNED AUTOS					COMBINED SINGLE LIMIT (Ea accident) \$ BODILY INJURY (Per person) \$ BODILY INJURY (Per accident) \$ PROPERTY DAMAGE (Per accident) \$ \$
	<b>UMBRELLA LIAB</b> <input type="checkbox"/> OCCUR <b>EXCESS LIAB</b> <input type="checkbox"/> CLAIMS-MADE DED      RETENTION \$					EACH OCCURRENCE \$ AGGREGATE \$ \$
	<b>WORKERS COMPENSATION AND EMPLOYERS' LIABILITY</b> ANY PROPRIETOR/PARTNER/EXECUTIVE OFFICER/MEMBER EXCLUDED? <input type="checkbox"/> Y <input checked="" type="checkbox"/> N (Mandatory in NH) If yes, describe under DESCRIPTION OF OPERATIONS below	N/A				WC STATUTORY LIMITS <input type="checkbox"/> OTH-ER <input type="checkbox"/> E.L. EACH ACCIDENT \$ E.L. DISEASE - EA EMPLOYEE \$ E.L. DISEASE - POLICY LIMIT \$

DESCRIPTION OF OPERATIONS / LOCATIONS / VEHICLES (Attach ACORD 101, Additional Remarks Schedule, if more space is required)

Regarding the General Liability coverage, Waiver of Subrogation applies to the entities listed below per attached form CG 24 04 when required by written agreement.

Regarding the General Liability coverage, Blanket Additional Insured applies to the entities listed below per attached form GLS-150s when required by written agreement.

Washington Co. Falegrounds  
 611 Hwy 1  
 Washington, IA. 52353

<b>CERTIFICATE HOLDER</b>  City of Washington 215 E. Washington St Washington IA 52353	<b>CANCELLATION</b>  SHOULD ANY OF THE ABOVE DESCRIBED POLICIES BE CANCELLED BEFORE THE EXPIRATION DATE THEREOF, NOTICE WILL BE DELIVERED IN ACCORDANCE WITH THE POLICY PROVISIONS.
	AUTHORIZED REPRESENTATIVE 

© 1988-2010 ACORD CORPORATION. All rights reserved.

POLICY NUMBER:

COMMERCIAL GENERAL LIABILITY  
CG 24 04 05 09

## WAIVER OF TRANSFER OF RIGHTS OF RECOVERY AGAINST OTHERS TO US

This endorsement modifies insurance provided under the following:

COMMERCIAL GENERAL LIABILITY COVERAGE PART  
PRODUCTS/COMPLETED OPERATIONS LIABILITY COVERAGE PART

### SCHEDULE

**Name Of Person Or Organization:**

Any person or organization with whom the insured has agreed to waive rights of recovery, provided such agreement is made in writing and prior to the loss.

Additional Premium is Included

Information required to complete this Schedule, if not shown above, will be shown in the Declarations.

The following is added to Paragraph 8. **Transfer Of Rights Of Recovery Against Others To Us** of Section IV - Conditions:

We waive any right of recovery we may have against the person or organization shown in the Schedule above because of payments we make for injury or damage arising out of your ongoing operations or "your work" done under a contract with that person or organization and included in the "products-completed operations hazard". This waiver applies only to the person or organization shown in the Schedule above.





ATTACHED TO AND FORMING A PART OF POLICY NUMBER	ENDORSEMENT EFFECTIVE DATE (12:01 A.M. STANDARD TIME)	NAMED INSURED	AGENT NO.

THIS ENDORSEMENT CHANGES THE POLICY. PLEASE READ IT CAREFULLY.

**BLANKET ADDITIONAL INSURED ENDORSEMENT**

This endorsement modifies insurance provided under the following:

**COMMERCIAL GENERAL LIABILITY COVERAGE PART**

With respect to this endorsement, **SECTION II—WHO IS AN INSURED** is amended to include as an additional insured any person or organization whom you are required to add as an additional insured on this policy under a written contract, written agreement or written permit which must be:

- a. Currently in effect or becoming effective during the term of the policy; and
- b. Executed prior to the "bodily injury," "property damage," or "personal and advertising injury."

The insurance provided to these additional insureds is limited as follows:

1. That person or organization is an additional insured only with respect to liability for "bodily injury," "property damage" or "personal and advertising injury" caused, in whole or in part, by:
  - a. Your acts or omissions; or
  - b. The acts or omissions of those acting on your behalf.

A person's or organization's status as an additional insured under this endorsement ends when your operations for that additional insured are completed.

2. With respect to the insurance afforded to these additional insureds, the following exclusions are added to item 2. **Exclusions of SECTION I—COVERAGES:**

This insurance does not apply to "bodily injury," "property damage" or "personal and advertising injury" occurring after:

- a. All work, including materials, parts or equipment furnished in connection with such work, on the project (other than service, maintenance or repairs) to be performed by or on behalf of the additional insured(s) at the location of the covered operations has been completed; or
  - b. That portion of "your work" out of which the injury or damage arises has been put to its intended use by any person or organization other than another contractor or subcontractor engaged in performing operations for a principal as a part of the same project.
3. The limits of insurance applicable to the additional insured are those specified in the written contract, written agreement or written permit or in the Declarations for this policy, whichever is less. These limits of insurance are inclusive of, and not in addition to, the Limits of Insurance shown in the Declarations for this policy.
  4. Coverage is not provided for "bodily injury," "property damage," or "personal and advertising injury" arising out of the sole negligence of the additional insured.
  5. The insurance provided to the additional insured does not apply to "bodily injury," "property damage," or "personal and advertising injury" arising out of an architect's, engineer's or surveyor's rendering of or failure to render any professional services including:

- a. The preparing, approving or failing to prepare or approve maps, shop drawings, opinions, reports, surveys, field orders, change orders or drawings and specifications; and
  - b. Supervisory, inspection, architectural or engineering activities.
6. Any coverage provided hereunder will be excess over any other valid and collectible insurance available to the additional insured whether primary, excess, contingent or on any other basis unless a

written contract specifically requires that this insurance be primary.

When this insurance is excess, we will have no duty under **SECTION I—COVERAGES** to defend the additional insured against any "suit" if any other insurer has a duty to defend the additional insured against that "suit." If no other insurer defends, we will undertake to do so, but we will be entitled to the additional insured's rights against all those other insurers.

---

AUTHORIZED REPRESENTATIVE

DATE

Includes copyrighted material of ISO Properties, Inc., with its permission.  
Copyright, ISO Properties, Inc., 2004



To contact us about this invoice:  
 Schneider Geospatial, LLC  
 Attn: Accounting Department  
 8901 Otis Avenue, Suite 300  
 Indianapolis, IN, 46216  
 317-826-7300  
 ar@schneiderGIS.com

## Invoice

**Date** 04/28/2023  
**Invoice #** I001786  
**Due Date** 06/30/2023  
**PO #**

**Bill To**  
 City Administrator  
 City of Washington, Iowa  
 215 East Washington St  
 Washington IA 52353

**For Technical Support:**  
**Phone:** 1-866-362-6789  
**Email:** support@schneiderGIS.com

dmccusker@washingtioniowa.gov

Page 1 of 1

**To pay by check:**  
 Schneider Geospatial, LLC  
 PO Box 7048, Group 13  
 Indianapolis, IN 46207-7048

**To pay by ACH (Preferred Payment Method):**  
 ABA/Routing#: 074900657 (First Merchants Bank)  
 Bank Account#: 9001324648  
 Remittance advice email: ar@schneiderGIS.com

<b>Products : SaaS : Beacon/qPublic.net : Contracted</b>	5/1/2023 - 6/30/2023	\$	1,038.00
Beacon : Hosting : Core			
Beacon : Hosting : Map			
Beacon : Hosting : Account Management			
<b>Products : SaaS : Beacon/qPublic.net : Implementation</b>		\$	5,000.00
Beacon : Setup : Core Setup			
Beacon : Setup : Mailing Labels			
<b>Products : SaaS : Custom : Hosting</b>	5/1/2023 - 6/30/2023	\$	238.00
Custom : Hosting : WFS/REST Hosting			
<b>Services : Consulting</b>		\$	2,340.00
Professional Services : Consulting - On Site GIS Consulting			
<b>Services : Staff Augmentation</b>	5/1/2023 - 6/30/2023	\$	584.00
Professional Services : Staff Augmentation : Flex Support			
		<b>Total</b>	\$ 9,200.00
		<b>Total Amount Due</b>	9,200.00

Please note that remittances are now payable to Schneider Geospatial, LLC for agreements previously entered into with The Schneider Corporation's geospatial division, qPublic, or qPublic.net.



SRF Consulting Group, Inc.  
 3701 Wayzata Boulevard, Suite 100  
 Minneapolis, MN 55416-3791

P. 763.475.0010  
 F. 1.866.440.6364

# INVOICE

Invoice Date: April 30, 2023  
 Invoice No: 16122.00 - 6

Ms. Deanna McCusker  
 City Administrator  
 City of Washington  
 215 East Washington Street  
 Washington, IA 52353

Email: dmccusker@washingtioniowa.gov

Re: Washington, IA Quiet Zone Study

**Professional Services for period ending April 30, 2023**

**Professional Personnel**

	Hours	Rate	Amount	
Professional VIII				
Mielke, Andrew	2.00	260.00	520.00	
<b>Totals</b>	2.00		<b>520.00</b>	<b>520.00</b>

**Budget Status**

	Budget	Current	Prior	To-Date
Total Billings	36,000.00	520.00	29,927.36	30,447.36
Remaining				5,552.64

**Total Amount Due this Invoice** **\$520.00**

THE CITY OF WASHINGTON

"Cleanest City in Iowa"



Jaron P. Rosien, Mayor  
Deanna McCusker, City Administrator  
Sally Y. Hart, City Clerk  
Kevin Olson, City Attorney

P.O. Box 516  
215 E. Washington St.  
Washington, IA 52353  
319-653-6584  
Fax Only 319-653-5273

NOTIFICATION FORM –

LIQUOR/BEER/CIGARETTE/DANCE

LICENSE RENEWALS

Business Name: **Hy-Vee Wine and Spirits**

Business Address: **528 Iowa Highway 1**

App #: **App-179631 for LE0001508**

Type of License:    New:            Renewal:            Special Five-Day:    Amendment: **X**  
Permanent Premise Transfer: **X**

Beer/Wine Permit:

Liquor License: **Class E Retail Alcohol License**

Automatic Renewal:

Cigarette License:

Dance Permit:

Sunday Sales: *\*Sunday sales are now an inherent privilege included in your license type with no additional fee. You are no longer required to choose Sunday Sales as a separate privilege.*

Living Quarters:

Outdoor Service Area:

Catering Privilege:

Date of Council Meeting: **May 16, 2023**

Police: DCI background check and/or local background check: Yes:            No:

Police Chief sign off  Date 4-28-2023

Fire: fire inspection done: Yes:            No:

Fire Chief sign off \_\_\_\_\_ Date \_\_\_\_\_



## Applicant

NAME OF LEGAL ENTITY	NAME OF BUSINESS(DBA)	BUSINESS		
Hy-Vee, Inc	Hy-Vee Wine & Spirits	(515) 267-2949		
ADDRESS OF PREMISES	PREMISES SUITE/APT NUMBER	CITY	COUNTY	ZIP
528 Iowa 1		Washington	Washington	52353
MAILING ADDRESS	CITY	STATE	ZIP	
5820 Westown Parkway	West Des Moines	Iowa	50266	

## Contact Person

NAME	PHONE	EMAIL
Kelly Palmer	(515) 267-2800	kpalmer@hy-vee.com

## License Information

LICENSE NUMBER	LICENSE/PERMIT TYPE	TERM	STATUS
LE0001508	Class E Retail Alcohol License	12 Month	Submitted to Local Authority

TENTATIVE EFFECTIVE DATE	TENTATIVE EXPIRATION DATE	LAST DAY OF BUSINESS
Feb 24, 2023	Feb 23, 2024	

SUB-PERMITS

Class E Retail Alcohol License

PRIVILEGES



## Status of Business

---

BUSINESS TYPE

Corporation

## Ownership

---

No Ownership information found

## Insurance Company Information

---

INSURANCE COMPANY

POLICY EFFECTIVE DATE

POLICY EXPIRATION DATE

DRAM CANCEL DATE

OUTDOOR SERVICE EFFECTIVE  
DATE

OUTDOOR SERVICE EXPIRATION  
DATE

BOND EFFECTIVE DATE

TEMP TRANSFER EFFECTIVE  
DATE

TEMP TRANSFER EXPIRATION  
DATE

THE CITY OF WASHINGTON

"Cleanest City in Iowa"



Jaron P. Rosien, Mayor  
Deanna McCusker, City Administrator  
Sally Y. Hart, City Clerk  
Kevin Olson, City Attorney

P.O. Box 516  
215 E. Washington St.  
Washington, IA 52353  
319-653-6584  
Fax Only 319-653-5273

NOTIFICATION FORM –

LIQUOR/BEER/CIGARETTE/DANCE

LICENSE RENEWALS

Business Name: 2 BROS MEXICAN BAR & GRILL, INC.

Business Address: 331 North 4<sup>th</sup> Avenue

App #: App-178282

Type of License:      New: X      Renewal:      Special Five-Day:      Amendment:

Beer/Wine Permit:

Liquor License: **Class C Retail Alcohol License**

Automatic Renewal:

Cigarette License:

Dance Permit:

Sunday Sales: *\*Sunday sales are now an inherent privilege included in your license type with no additional fee. You are no longer required to choose Sunday Sales as a separate privilege.*

Living Quarters:

Outdoor Service Area:

Catering Privilege:

Date of Council Meeting: **May 2, 2023**

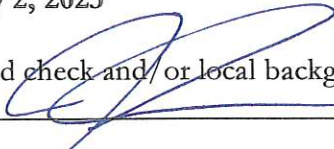
Police: DCI background check and/or local background check: Yes:  No:   
Police Chief sign off  Date 4-21-2023

Fire: fire inspection done: Yes:  No:   
Fire Chief sign off \_\_\_\_\_ Date \_\_\_\_\_





## Applicant

NAME OF LEGAL ENTITY	NAME OF BUSINESS(DBA)	BUSINESS			
2 BROS MEXICAN BAR & GRILL, INC.	2 BROS MEXICAN BAR & GRILL	(319) 458-9920			
ADDRESS OF PREMISES	PREMISES SUITE/APT NUMBER	CITY	COUNTY	ZIP	
331 North 4th Avenue		Washington	Washington	52353	
MAILING ADDRESS	CITY	STATE	ZIP		
609 East Washington Street	Washington	Iowa	52353		

## Contact Person

NAME	PHONE	EMAIL
SIDRONIO MIJANGOS CRUZ	(319) 458-9920	sjaccg.payroll@gmail.com

## License Information

LICENSE NUMBER	LICENSE/PERMIT TYPE	TERM	STATUS
	Class C Retail Alcohol License	12 Month	Submitted to Local Authority

TENTATIVE EFFECTIVE DATE	TENTATIVE EXPIRATION DATE	LAST DAY OF BUSINESS
May 1, 2023	Apr 30, 2024	

### SUB-PERMITS

Class C Retail Alcohol License



## Status of Business

BUSINESS TYPE

Corporation

## Ownership

### • Individual Owners

NAME	CITY	STATE	ZIP	POSITION	% OF OWNERSHIP	U.S. CITIZEN
SIDRONIO MIJANGOS CRUZ	Washington	Iowa	52353	PRESIDENT	50.00	No
MISAEAL MIJANGOS CRUZ	Washington	Iowa	52353	VICE PRESIDENT	50.00	Yes

## Insurance Company Information

INSURANCE COMPANY

Society Insurance

POLICY EFFECTIVE DATE

May 1, 2023

POLICY EXPIRATION DATE

May 1, 2024

DRAM CANCEL DATE

OUTDOOR SERVICE EFFECTIVE DATE

OUTDOOR SERVICE EXPIRATION DATE

BOND EFFECTIVE DATE

TEMP TRANSFER EFFECTIVE DATE

TEMP TRANSFER EXPIRATION DATE

**Instructions on the reverse side**

For period (MM/DD/YYYY) 7 / 1 / 2023 through June 30, 2024

I/we apply for a retail permit to sell cigarettes, tobacco, alternative nicotine, or vapor products:

**Business Information:**

Trade name/Doing business as: Hy-Vee Food Store

Physical location address: 528 S. Hwy #1 City: Washington ZIP: 52353

Mailing address: 5820 Westown Pkwy City: West Des Moines State: IA ZIP: 50266

Business phone number: 319-653-5406

**Legal Ownership Information:**

Type of Ownership: Sole Proprietor  Partnership  Corporation  LLC  LLP

Name of sole proprietor, partnership, corporation, LLC, or LLP Hy-Vee, Inc.

Mailing address: 5820 Westown Pkwy City: West Des Moines State: IA ZIP: 50266

Phone number: 515-267-2800 ext 4216 Fax number: \_\_\_\_\_ Email: knylen@hy-vee.com

**Retail Information:**

Types of Sales: Over-the-counter  Vending machine

Do you make delivery sales of alternative nicotine or vapor products? (See Instructions) Yes  No

Types of Products Sold: (Check all that apply)

Cigarettes  Tobacco  Alternative Nicotine Products  Vapor Products

**Type of Establishment: (Select the option that best describes the establishment)**

Alternative nicotine/vapor store  Bar  Convenience store/gas station  Drug store   
Grocery store  Hotel/motel  Liquor store  Restaurant  Tobacco store   
Has vending machine that assembles cigarettes  Other  \_\_\_\_\_

If application is approved and permit granted, I/we do hereby bind ourselves to a faithful observance of the laws governing the sale of cigarettes, tobacco, alternative nicotine, and vapor products.

**Signature of Owner(s), Partner(s), or Corporate Official(s)**

Name (please print): \_\_\_\_\_  
Signature: [Handwritten Signature]  
Date: 5/1/23

Name (please print): ANDREW SCHROEDER  
Signature: Senior Vice President,  
Date: Accounting, Controller

Send this completed application and the applicable fee to your local jurisdiction. If you have any questions contact your city clerk (within city limits) or your county auditor (outside city limits).

**FOR CITY CLERK/COUNTY AUDITOR ONLY – MUST BE COMPLETE**

- Fill in the amount paid for the permit: \_\_\_\_\_
- Fill in the date the permit was approved by the council or board: \_\_\_\_\_
- Fill in the permit number issued by the city/county: \_\_\_\_\_
- Fill in the name of the city or county issuing the permit: \_\_\_\_\_
- New  Renewal

Send completed/approved application to Iowa Alcoholic Beverages Division within 30 days of issuance. Make sure the information on the application is complete and accurate. A copy of the permit does not need to be sent; only the application is required. It is preferred that applications are sent via email, as this allows for a receipt confirmation to be sent to the local authority.

- Email: [iapledge@iowaabd.com](mailto:iapledge@iowaabd.com)
- Fax: 515-281-7375

**Instructions on the reverse side**

For period (MM/DD/YYYY) 7 / 1 / 2023 through June 30, 2024

I/we apply for a retail permit to sell cigarettes, tobacco, alternative nicotine, or vapor products:

**Business Information:**

Trade name/Doing business as: Hy-Vee Fast & Fresh

Physical location address: 520 S. Hwy #1 City: Washington ZIP: 52353

Mailing address: 5820 Westown Pkwy City: West Des Moines State: IA ZIP: 50266

Business phone number: 319-653-3039

**Legal Ownership Information:**

Type of Ownership: Sole Proprietor  Partnership  Corporation  LLC  LLP

Name of sole proprietor, partnership, corporation, LLC, or LLP Hy-Vee, Inc.

Mailing address: 5820 Westown Pkwy City: West Des Moines State: IA ZIP: 50266

Phone number: 515-267-2800 ext 4216 Fax number: \_\_\_\_\_ Email: knylen@hy-vee.com

**Retail Information:**

Types of Sales: Over-the-counter  Vending machine

Do you make delivery sales of alternative nicotine or vapor products? (See Instructions) Yes  No

Types of Products Sold: (Check all that apply)

Cigarettes  Tobacco  Alternative Nicotine Products  Vapor Products

**Type of Establishment: (Select the option that best describes the establishment)**

Alternative nicotine/vapor store  Bar  Convenience store/gas station  Drug store   
Grocery store  Hotel/motel  Liquor store  Restaurant  Tobacco store   
Has vending machine that assembles cigarettes  Other  \_\_\_\_\_

If application is approved and permit granted, I/we do hereby bind ourselves to a faithful observance of the laws governing the sale of cigarettes, tobacco, alternative nicotine, and vapor products.

**Signature of Owner(s), Partner(s), or Corporate Official(s)**

Name (please print): \_\_\_\_\_  
Signature: [Handwritten Signature]  
Date: 3/14/23

Name (please print): ANDREW SCHROEDER  
Signature: Senior Vice President,  
Accounting, Controller  
Date: \_\_\_\_\_

Send this completed application and the applicable fee to your local jurisdiction. If you have any questions contact your city clerk (within city limits) or your county auditor (outside city limits).

**FOR CITY CLERK/COUNTY AUDITOR ONLY – MUST BE COMPLETE**

- Fill in the amount paid for the permit: \_\_\_\_\_
- Fill in the date the permit was approved by the council or board: \_\_\_\_\_
- Fill in the permit number issued by the city/county: \_\_\_\_\_
- Fill in the name of the city or county issuing the permit: \_\_\_\_\_
- New  Renewal

Send completed/approved application to Iowa Alcoholic Beverages Division within 30 days of issuance. Make sure the information on the application is complete and accurate. A copy of the permit does not need to be sent; only the application is required. It is preferred that applications are sent via email, as this allows for a receipt confirmation to be sent to the local authority.

- Email: [iapledge@iowaabd.com](mailto:iapledge@iowaabd.com)
- Fax: 515-281-7375

**Instructions on the reverse side**

For period (MM/DD/YYYY) 06 / 30 / 2023 through June 30, 2024

I/we apply for a retail permit to sell cigarettes, tobacco, alternative nicotine, or vapor products:

**Business Information:**

Trade name/Doing business as: Walmart Inc. dba Walmart #1475

Physical location address: 2485 Highway 92 City: Washington ZIP: 52353

Mailing address: 702 SW 8th St. Mail Stop 0500. City: Bentonville State: AR ZIP: 72716-0500

Business phone number: (319)653-7213

**Legal Ownership Information:**

Type of Ownership: Sole Proprietor  Partnership  Corporation  LLC  LLP

Name of sole proprietor, partnership, corporation, LLC, or LLP Walmart Inc.

Mailing address: 702 SW 8th St. Mail Stop 0500. City: Bentonville State: AR ZIP: 72716-0500

Phone number: (479)371-0964 Fax number: \_\_\_\_\_ Email: complic@wal-mart.com

**Retail Information:**

Types of Sales: Over-the-counter  Vending machine

Do you make delivery sales of alternative nicotine or vapor products? (See Instructions) Yes  No

Types of Products Sold: (Check all that apply)

Cigarettes  Tobacco  Alternative Nicotine Products  Vapor Products

**Type of Establishment: (Select the option that best describes the establishment)**

Alternative nicotine/vapor store  Bar  Convenience store/gas station  Drug store   
Grocery store  Hotel/motel  Liquor store  Restaurant  Tobacco store   
Has vending machine that assembles cigarettes  Other  Retail

If application is approved and permit granted, I/we do hereby bind ourselves to a faithful observance of the laws governing the sale of cigarettes, tobacco, alternative nicotine, and vapor products.

**Signature of Owner(s), Partner(s), or Corporate Official(s)**

Name (please print): Sarah Little

Name (please print): \_\_\_\_\_

Signature: 

Signature: \_\_\_\_\_

Date: 4/26/2023

Date: \_\_\_\_\_

Send this completed application and the applicable fee to your local jurisdiction. If you have any questions contact your city clerk (within city limits) or your county auditor (outside city limits).

**FOR CITY CLERK/COUNTY AUDITOR ONLY – MUST BE COMPLETE**

- Fill in the amount paid for the permit: \_\_\_\_\_
- Fill in the date the permit was approved by the council or board: \_\_\_\_\_
- Fill in the permit number issued by the city/county: \_\_\_\_\_
- Fill in the name of the city or county issuing the permit: \_\_\_\_\_
- New  Renewal

Send completed/approved application to Iowa Alcoholic Beverages Division within 30 days of issuance. Make sure the information on the application is complete and accurate. A copy of the permit does not need to be sent; only the application is required. It is preferred that applications are sent via email, as this allows for a receipt confirmation to be sent to the local authority.

- Email: [iapledge@iowaabd.com](mailto:iapledge@iowaabd.com)
- Fax: 515-281-7375

Instructions on the reverse side

For period (MM/DD/YYYY) 07/01/2023 through June 30, 2024

I/we apply for a retail permit to sell cigarettes, tobacco, alternative nicotine, or vapor products:

**Business Information:**

Trade name/Doing business as: BP One Trip  
Physical location address: 1504 East Washington St. City: Washington ZIP: 52353  
Mailing address: P.O. Box 178 City: Brighton State: IA ZIP: 52540  
Business phone number: 319-653-2243

**Legal Ownership Information:**

Type of Ownership: Sole Proprietor  Partnership  Corporation  LLC  LLP   
Name of sole proprietor, partnership, corporation, LLC, or LLP: Cobb Oil Co, Inc.  
Mailing address: P.O. Box 178 City: Brighton State: IA ZIP: 52540  
Phone number: 319-694-2200 Fax number: 319-694-2201 Email: lcobb@cobboil.com

**Retail Information:**

Types of Sales: Over-the-counter  Vending machine   
Do you make delivery sales of alternative nicotine or vapor products? (See Instructions) Yes  No   
Types of Products Sold: (Check all that apply)  
Cigarettes  Tobacco  Alternative Nicotine Products  Vapor Products

**Type of Establishment: (Select the option that best describes the establishment)**

Alternative nicotine/vapor store  Bar  Convenience store/gas station  Drug store   
Grocery store  Hotel/motel  Liquor store  Restaurant  Tobacco store   
Has vending machine that assembles cigarettes  Other

If application is approved and permit granted, I/we do hereby bind ourselves to a faithful observance of the laws governing the sale of cigarettes, tobacco, alternative nicotine, and vapor products.

**Signature of Owner(s), Partner(s), or Corporate Official(s)**

Name (please print): Laura Cobb Name (please print): \_\_\_\_\_  
Signature: Laura Cobb Signature: \_\_\_\_\_  
Date: 5-1-23 Date: \_\_\_\_\_

Send this completed application and the applicable fee to your local jurisdiction. If you have any questions contact your city clerk (within city limits) or your county auditor (outside city limits).

**FOR CITY CLERK/COUNTY AUDITOR ONLY – MUST BE COMPLETE**

- Fill in the amount paid for the permit: \_\_\_\_\_
- Fill in the date the permit was approved by the council or board: \_\_\_\_\_
- Fill in the permit number issued by the city/county: \_\_\_\_\_
- Fill in the name of the city or county issuing the permit: \_\_\_\_\_
- New  Renewal

Send completed/approved application to Iowa Alcoholic Beverages Division within 30 days of issuance. Make sure the information on the application is complete and accurate. A copy of the permit does not need to be sent; only the application is required. It is preferred that applications are sent via email, as this allows for a receipt confirmation to be sent to the local authority.

- Email: [iapledge@iowaabd.com](mailto:iapledge@iowaabd.com)
- Fax: 515-281-7375

**Instructions on the reverse side**

For period (MM/DD/YYYY) 07 / 01 / 23 through June 30, 2024

I/we apply for a retail permit to sell cigarettes, tobacco, alternative nicotine, or vapor products:

**Business Information:**

Trade name/Doing business as: Fareway Stores, Inc. # 554  
Physical location address: 301 North Marion Avenue City: WASHINGTON ZIP: 52353  
Mailing address: 301 North Marion Avenue City: WASHINGTON State: IA ZIP: 52353  
Business phone number: 319 653-5064

**Legal Ownership Information:**

Type of Ownership: Sole Proprietor  Partnership  Corporation  LLC  LLP   
Name of sole proprietor, partnership, corporation, LLC, or LLP Fareway Stores, Inc.  
Mailing address: PO Box 70 City: Boone State: IA ZIP: 50036  
Phone number: 515-433-5336 Fax number: 515-433-4416 Email: storelicenses@farewaystores.com

**Retail Information:**

Types of Sales: Over-the-counter  Vending machine   
Do you make delivery sales of alternative nicotine or vapor products? (See Instructions) Yes  No   
Types of Products Sold: (Check all that apply)  
Cigarettes  Tobacco  Alternative Nicotine Products  Vapor Products

**Type of Establishment: (Select the option that best describes the establishment)**

Alternative nicotine/vapor store  Bar  Convenience store/gas station  Drug store   
Grocery store  Hotel/motel  Liquor store  Restaurant  Tobacco store   
Has vending machine that assembles cigarettes  Other

If application is approved and permit granted, I/we do hereby bind ourselves to a faithful observance of the laws governing the sale of cigarettes, tobacco, alternative nicotine, and vapor products.

**Signature of Owner(s), Partner(s), or Corporate Official(s)**

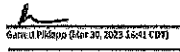
Name (please print): Garrett S. Piklapp Name (please print): \_\_\_\_\_  
Signature:  Signature: \_\_\_\_\_  
Date: Mar 30, 2023 Date: \_\_\_\_\_

Send this completed application and the applicable fee to your local jurisdiction. If you have any questions contact your city clerk (within city limits) or your county auditor (outside city limits).

**FOR CITY CLERK/COUNTY AUDITOR ONLY – MUST BE COMPLETE**

- Fill in the amount paid for the permit: \_\_\_\_\_
- Fill in the date the permit was approved by the council or board: \_\_\_\_\_
- Fill in the permit number issued by the city/county: \_\_\_\_\_
- Fill in the name of the city or county issuing the permit: \_\_\_\_\_
- New  Renewal

Send completed/approved application to Iowa Alcoholic Beverages Division within 30 days of issuance. Make sure the information on the application is complete and accurate. A copy of the permit does not need to be sent; only the application is required. It is preferred that applications are sent via email, as this allows for a receipt confirmation to be sent to the local authority.

- Email: [iapledge@iowaabd.com](mailto:iapledge@iowaabd.com)
- Fax: 515-281-7375

Instructions on the reverse side

For period (MM/DD/YYYY) July 1 / 1 / 2023 through June 30, 2024

I/we apply for a retail permit to sell cigarettes, tobacco, alternative nicotine, or vapor products:

**Business Information:**

Trade name/Doing business as: Washington liquor & tobacco outlet  
Physical location address: 304 West Madison St City: Washington ZIP: 52353  
Mailing address: 304 West Madison St City: Washington State: IA ZIP: 52353  
Business phone number: 319-591-8365

**Legal Ownership Information:**

Type of Ownership: Sole Proprietor  Partnership  Corporation  LLC  LLP   
Name of sole proprietor, partnership, corporation, LLC, or LLP D & P holding LLC  
Mailing address: 304 West Madison St City: Washington State: IA ZIP: 52353  
Phone number: 563549-3600 Fax number: \_\_\_\_\_ Email: dnp holding llc 304@gmail.com

**Retail Information:**

Types of Sales: Over-the-counter  Vending machine   
Do you make delivery sales of alternative nicotine or vapor products? (See Instructions) Yes  No   
Types of Products Sold: (Check all that apply)  
Cigarettes  Tobacco  Alternative Nicotine Products  Vapor Products

**Type of Establishment: (Select the option that best describes the establishment)**

Alternative nicotine/vapor store  Bar  Convenience store/gas station  Drug store   
Grocery store  Hotel/motel  Liquor store  Restaurant  Tobacco store   
Has vending machine that assembles cigarettes  Other  \_\_\_\_\_

If application is approved and permit granted, I/we do hereby bind ourselves to a faithful observance of the laws governing the sale of cigarettes, tobacco, alternative nicotine, and vapor products.

**Signature of Owner(s), Partner(s), or Corporate Official(s)**

Name (please print): Pramod Gajurel Name (please print): Durga Gajurel  
Signature: [Signature] Signature: [Signature]  
Date: \_\_\_\_\_ Date: \_\_\_\_\_

Send this completed application and the applicable fee to your local jurisdiction. If you have any questions contact your city clerk (within city limits) or your county auditor (outside city limits).

**FOR CITY CLERK/COUNTY AUDITOR ONLY - MUST BE COMPLETE**

- Fill in the amount paid for the permit: \_\_\_\_\_
- Fill in the date the permit was approved by the council or board: \_\_\_\_\_
- Fill in the permit number issued by the city/county: \_\_\_\_\_
- Fill in the name of the city or county issuing the permit: \_\_\_\_\_
- New  Renewal

Send completed/approved application to Iowa Alcoholic Beverages Division within 30 days of issuance. Make sure the information on the application is complete and accurate. A copy of the permit does not need to be sent; only the application is required. It is preferred that applications are sent via email, as this allows for a receipt confirmation to be sent to the local authority.

- Email: [iapledge@iowaabd.com](mailto:iapledge@iowaabd.com)
- Fax: 515-281-7375



Instructions on the reverse side

For period (MM/DD/YYYY) 07 / 01 / 2023 through June 30, 2024

I/we apply for a retail permit to sell cigarettes, tobacco, alternative nicotine, or vapor products:

**Business Information:**

Trade name/Doing business as: WINE & SPIRITS

Physical location address: 106 W 2ND ST City: WASHINGTON ZIP: 52353

Mailing address: 106 W 2ND ST City: WASHINGTON State: IA ZIP: 52353

Business phone number: 319-653-2822

**Legal Ownership Information:**

Type of Ownership: Sole Proprietor  Partnership  Corporation  LLC  LLP

Name of sole proprietor, partnership, corporation, LLC, or LLP T&J WALSH, INC

Mailing address: 106 W 2ND ST City: WASHINGTON State: IA ZIP: 52353

Phone number: 319-653-2822 Fax number: \_\_\_\_\_ Email: winespirits@hotmail.com

**Retail Information:**

Types of Sales: Over-the-counter  Vending machine

Do you make delivery sales of alternative nicotine or vapor products? (See Instructions) Yes  No

Types of Products Sold: (Check all that apply)

Cigarettes  Tobacco  Alternative Nicotine Products  Vapor Products

**Type of Establishment: (Select the option that best describes the establishment)**

Alternative nicotine/vapor store  Bar  Convenience store/gas station  Drug store   
Grocery store  Hotel/motel  Liquor store  Restaurant  Tobacco store

Has vending machine that assembles cigarettes  Other  \_\_\_\_\_

If application is approved and permit granted, I/we do hereby bind ourselves to a faithful observance of the laws governing the sale of cigarettes, tobacco, alternative nicotine, and vapor products.

**Signature of Owner(s), Partner(s), or Corporate Official(s)**

Name (please print): ANTHONY WALSH

Name (please print): \_\_\_\_\_

Signature: [Signature]

Signature: \_\_\_\_\_

Date: 4-29-23

Date: \_\_\_\_\_

Send this completed application and the applicable fee to your local jurisdiction. If you have any questions contact your city clerk (within city limits) or your county auditor (outside city limits).

**FOR CITY CLERK/COUNTY AUDITOR ONLY – MUST BE COMPLETE**

- Fill in the amount paid for the permit: \_\_\_\_\_
- Fill in the date the permit was approved by the council or board: \_\_\_\_\_
- Fill in the permit number issued by the city/county: \_\_\_\_\_
- Fill in the name of the city or county issuing the permit: \_\_\_\_\_
- New  Renewal

Send completed/approved application to Iowa Alcoholic Beverages Division within 30 days of issuance. Make sure the information on the application is complete and accurate. A copy of the permit does not need to be sent; only the application is required. It is preferred that applications are sent via email, as this allows for a receipt confirmation to be sent to the local authority.

- Email: [iapledge@iowaabd.com](mailto:iapledge@iowaabd.com)
- Fax: 515-281-7375

**Instructions on the reverse side**

For period (MM/DD/YYYY) 07 / 01 / 2023 through June 30, 2024

I/we apply for a retail permit to sell cigarettes, tobacco, alternative nicotine, or vapor products:

**Business Information:**

Trade name/Doing business as: CASEY'S MARKETING COMPANY/DBA CASEY'S #1624  
Physical location address: 1002 W MADISON ST City: WASHINGTON ZIP: 52353  
Mailing address: 1 SE CONVENIENCE BLVD City: ANKENY State: IA ZIP: 50021  
Business phone number: 3198639040

**Legal Ownership Information:**

Type of Ownership: Sole Proprietor  Partnership  Corporation  LLC  LLP   
Name of sole proprietor, partnership, corporation, LLC, or LLP CASEY'S GENERAL STORES, INC.  
Mailing address: 1 SE CONVENIENCE BLVD City: ANKENY State: IA ZIP: 50021  
Phone number: 5153815974 Fax number: 515-446-6303 Email: licensingteam@caseys.com

**Retail Information:**

Types of Sales: Over-the-counter  Vending machine   
Do you make delivery sales of alternative nicotine or vapor products? (See Instructions) Yes  No   
Types of Products Sold: (Check all that apply)  
Cigarettes  Tobacco  Alternative Nicotine Products  Vapor Products

**Type of Establishment: (Select the option that best describes the establishment)**

Alternative nicotine/vapor store  Bar  Convenience store/gas station  Drug store   
Grocery store  Hotel/motel  Liquor store  Restaurant  Tobacco store   
Has vending machine that assembles cigarettes  Other

If application is approved and permit granted, I/we do hereby bind ourselves to a faithful observance of the laws governing the sale of cigarettes, tobacco, alternative nicotine, and vapor products.

**Signature of Owner(s), Partner(s), or Corporate Official(s)**

Name (please print): DOUGLAS BEECH, AST. SECRETARY FOR CASEY'S MARKETING COMPANY

Name (please print): \_\_\_\_\_

Signature: *Douglas M. Beech*

Signature: \_\_\_\_\_

Date: 04/18/2023

Date: \_\_\_\_\_

Send this completed application and the applicable fee to your local jurisdiction. If you have any questions contact your city clerk (within city limits) or your county auditor (outside city limits).

**FOR CITY CLERK/COUNTY AUDITOR ONLY – MUST BE COMPLETE**

- Fill in the amount paid for the permit: \_\_\_\_\_
- Fill in the date the permit was approved by the council or board: \_\_\_\_\_
- Fill in the permit number issued by the city/county: \_\_\_\_\_
- Fill in the name of the city or county issuing the permit: \_\_\_\_\_
- New  Renewal

Send completed/approved application to Iowa Alcoholic Beverages Division within 30 days of issuance. Make sure the information on the application is complete and accurate. A copy of the permit does not need to be sent; only the application is required. It is preferred that applications are sent via email, as this allows for a receipt confirmation to be sent to the local authority.

- Email: [iapledge@iowaabd.com](mailto:iapledge@iowaabd.com)
- Fax: 515-281-7375

**Instructions on the reverse side**

For period (MM/DD/YYYY) 07 / 01 / 2023 through June 30, 2024

I/we apply for a retail permit to sell cigarettes, tobacco, alternative nicotine, or vapor products:

**Business Information:**

Trade name/Doing business as: CASEY'S MARKETING COMPANY/DBA CASEY'S #3528  
Physical location address: 1730 E WASHINGTON ST City: WASHINGTON ZIP: 52353  
Mailing address: 1 SE CONVENIENCE BLVD City: ANKENY State: IA ZIP: 50021  
Business phone number: 3196537437

**Legal Ownership Information:**

Type of Ownership: Sole Proprietor  Partnership  Corporation  LLC  LLP   
Name of sole proprietor, partnership, corporation, LLC, or LLP CASEY'S GENERAL STORES, INC.  
Mailing address: 1 SE CONVENIENCE BLVD City: ANKENY State: IA ZIP: 50021  
Phone number: 5153815974 Fax number: 515-446-6303 Email: licensingteam@caseys.com

**Retail Information:**

Types of Sales: Over-the-counter  Vending machine   
Do you make delivery sales of alternative nicotine or vapor products? (See Instructions) Yes  No   
Types of Products Sold: (Check all that apply)  
Cigarettes  Tobacco  Alternative Nicotine Products  Vapor Products

**Type of Establishment: (Select the option that best describes the establishment)**

Alternative nicotine/vapor store  Bar  Convenience store/gas station  Drug store   
Grocery store  Hotel/motel  Liquor store  Restaurant  Tobacco store   
Has vending machine that assembles cigarettes  Other

If application is approved and permit granted, I/we do hereby bind ourselves to a faithful observance of the laws governing the sale of cigarettes, tobacco, alternative nicotine, and vapor products.

**Signature of Owner(s), Partner(s), or Corporate Official(s)**

Name (please print): DOUGLAS BEECH, AST. SECRETARY FOR CASEY'S MARKETING COMPANY Name (please print): \_\_\_\_\_  
Signature: *Douglas M. Beech* Signature: \_\_\_\_\_  
Date: 04/18/2023 Date: \_\_\_\_\_

Send this completed application and the applicable fee to your local jurisdiction. If you have any questions contact your city clerk (within city limits) or your county auditor (outside city limits).

**FOR CITY CLERK/COUNTY AUDITOR ONLY – MUST BE COMPLETE**

- Fill in the amount paid for the permit: \_\_\_\_\_
- Fill in the date the permit was approved by the council or board: \_\_\_\_\_
- Fill in the permit number issued by the city/county: \_\_\_\_\_
- Fill in the name of the city or county issuing the permit: \_\_\_\_\_
- New  Renewal

Send completed/approved application to Iowa Alcoholic Beverages Division within 30 days of issuance. Make sure the information on the application is complete and accurate. A copy of the permit does not need to be sent; only the application is required. It is preferred that applications are sent via email, as this allows for a receipt confirmation to be sent to the local authority.

- Email: [iapledge@iowaabd.com](mailto:iapledge@iowaabd.com)
- Fax: 515-281-7375

THE CITY OF WASHINGTON

"Cleanest City in Iowa"



Jaron P. Rosien, Mayor  
Deanna McCusker, City Administrator  
Sally Y. Hart, City Clerk  
Kevin Olson, City Attorney

P.O. Box 516  
215 E. Washington St.  
Washington, IA 52353  
319-653-6584  
Fax Only 319-653-5273

NOTIFICATION FORM -  
LIQUOR/BEER/CIGARETTE/DANCE  
LICENSE RENEWALS

Business Name: **The Topsy Traveler's LLC**

Business Address: **107 West 2<sup>nd</sup> Street**

App # : **App-180641**

Type of License:    New:            Renewal:    Special Five-Day: **X**    Amendment:  
Permanent Premise Transfer:

Beer/Wine Permit:

Liquor License: **Special Class C Retail Alcohol License (May 17-22)**

Automatic Renewal:

Cigarette License:

Dance Permit:

Sunday Sales: *\*Sunday sales are now an inherent privilege included in your license type with no additional fee. You are no longer required to choose Sunday Sales as a separate privilege.*

Living Quarters:

Outdoor Service Area:

Catering Privilege:

Date of Council Meeting: **May 16, 2023**

Police: DCI background check and/or local background check:    Yes:            No:  
Police Chief sign off \_\_\_\_\_ . Date \_\_\_\_\_ .

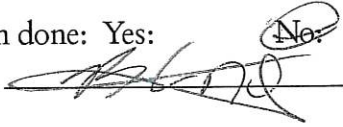
Fire: fire inspection done: Yes:            No: **No**  
Fire Chief sign off  . Date **5/16/23**

THE CITY OF WASHINGTON

"Cleanest City in Iowa"



Jaron P. Rosien, Mayor  
Deanna McCusker, City Administrator  
Sally Y. Hart, City Clerk  
Kevin Olson, City Attorney

P.O. Box 516  
215 E. Washington St.  
Washington, IA 52353  
319-653-6584  
Fax Only 319-653-5273

NOTIFICATION FORM -  
LIQUOR/BEER/CIGARETTE/DANCE  
LICENSE RENEWALS

Business Name: **The Tipsy Traveler's LLC**

Business Address: **107 West 2<sup>nd</sup> Street**

App # : **App-180641**

Type of License:    New:            Renewal:    Special Five-Day: **X**    Amendment:  
Permanent Premise Transfer:

Beer/Wine Permit:

Liquor License: **Special Class C Retail Alcohol License (May 17-22)**

Automatic Renewal:

Cigarette License:

Dance Permit:

Sunday Sales: *\*Sunday sales are now an inherent privilege included in your license type with no additional fee. You are no longer required to choose Sunday Sales as a separate privilege.*

Living Quarters:

Outdoor Service Area:

Catering Privilege:

Date of Council Meeting: **May 16, 2023**

Police: DCI background check and/or local background check: Yes:    No:  
Police Chief sign off  . Date 5-11-2023

Fire: fire inspection done: Yes:            No:  
Fire Chief sign off \_\_\_\_\_ . Date \_\_\_\_\_



## Applicant

NAME OF LEGAL ENTITY	NAME OF BUSINESS(DBA)	BUSINESS		
THE TIPSY TRAVELER'S LLC	THE TIPSY TRAVELERS	(319) 201-0470		
ADDRESS OF PREMISES	PREMISES SUITE/APT NUMBER	CITY	COUNTY	ZIP
107 West 2nd Street		Washington	Washington	52353
MAILING ADDRESS	CITY	STATE	ZIP	
107 West 2nd Street	Washington	Iowa	52353	

## Contact Person

NAME	PHONE	EMAIL
megan libe	(319) 201-0470	tipsytravelrs@gmail.com

## License Information

LICENSE NUMBER	LICENSE/PERMIT TYPE	TERM	STATUS
	Special Class C Retail Alcohol License	5 Day	Submitted to Local Authority

TENTATIVE EFFECTIVE DATE	TENTATIVE EXPIRATION DATE	LAST DAY OF BUSINESS
May 17, 2023	May 21, 2023	

### SUB-PERMITS

Special Class C Retail Alcohol License

### PRIVILEGES



## Status of Business

BUSINESS TYPE

Limited Liability Company

## Ownership

### • Individual Owners

NAME	CITY	STATE	ZIP	POSITION	% OF OWNERSHIP	U.S. CITIZEN
Megan Libe	Keota	Iowa	52248	Owner	100.00	Yes

## Insurance Company Information

INSURANCE COMPANY

Founders Insurance Company

POLICY EFFECTIVE DATE

May 17, 2023

POLICY EXPIRATION DATE

May 22, 2023

DRAM CANCEL DATE

OUTDOOR SERVICE EFFECTIVE DATE

OUTDOOR SERVICE EXPIRATION DATE

BOND EFFECTIVE DATE

TEMP TRANSFER EFFECTIVE DATE

TEMP TRANSFER EXPIRATION DATE

*Millie Youngquist, Mayor Pro Tem  
Deanna McCusker, City Administrator  
Kelsey Brown, Finance Director  
Sally Hart, City Clerk  
Kevin Olson, City Attorney*



*City of Washington  
215 East Washington Street  
Washington, Iowa 52353  
(319) 653-6584 Phone  
(319) 653-5273 Fax*

---

City Administrator Report  
May 16, 2023

Project Updates:

**Country Club View Subdivision:** The intersection of Country Club Road and Augusta National will be getting done on Monday, May 15. Also the intersection of E Ave & Augusta National and Nutmeg and E Ave will also be getting done next week. Then the intakes will be getting finished.

**East Adams:** The concrete company is planning on coming by the end of next week or sooner depending on the weather to pour sidewalks. There will be final grading and seeding to be done following.

**Water Main:** The main replacement on E Main is almost done where open trenching is occurring, then water testing will be done and then service line connections will start.

**Buchanan Street:** DeLong will be coming in next week to till up the areas that need reseeded and then will reseed.

Other updates: Working on documents for the urban renewal amendment, working on cleaning up nuisances that are still open and have developed policies and procedures for specific nuisances, had some municipal infraction citations mailed/delivered on some houses that need to finish siding, attended the administrative hearing on a nuisance property that is asking for additional time to complete, worked with Kevin on getting information from insurance company on the downtown fire, reached out for brick restoration companies to assist with the downtown building if insurance does not take the proper steps. We are going to be adding information to our June utility bills, a letter/survey and posts on our website about the lead service inventory so drafting the survey. Reviewed information on the Egg Sewer and our water main map that shows size and flow with JJ. We are accepting internal applications for the Assistant Superintendent since Zach is the new Cemetery Sexton. Deadline is Monday, May 15. Have been assisting with building permits as needed.

Meetings attended: Meeting to discuss and review rental inspections again, Main Street meeting, Economic Vitality meeting, meeting with concerned property owner regarding 217 W Main and an interested party in the building also, Planning and Zoning meeting, nuisance meeting, attended Leadership Washington graduation, meeting to review issues from the South Ave E project with a property owner.



Next week's meetings include: Library Makerspace meeting, Housing Initiative, Water Main progress meeting, GIS onsite meeting, employee benefits seminar, WEDG Meeting. Additionally, some council one on ones and department head one on ones.

Washington Fire Department  
215 East Washington Street  
Washington, Iowa 52353  
(319) 653-2239 Phone  
(319) 653-5273 Fax  
[www.washingtoniowa.gov](http://www.washingtoniowa.gov)



Brendan DeLong- Fire Chief  
Bill Hartsock- 1<sup>st</sup> Asst Fire Chief  
Jim Williams- 2<sup>nd</sup> Asst Fire Chief  
Carrie Ornduff- Asst Chief of EMS

---

---

### April 2023 Activity Report

Structure fires- 2  
Vehicle Fires – 1  
Weather related- 0  
Mutual aid assists- 6  
Hazardous Incidents- 1  
Grass fires- 2  
Investigate/good intent- 8  
Rescue/accidents- 6  
Medical- 63

### April calls for service- 89

EMS Continues to be busy with 63 calls for service in April. Fire calls were elevated in the month of April. Washington responded to 26 fire calls. That amounts to about 1 per day. On one Saturday in April, we responded to 9 fire and 3 medical calls during the same day. Our crews do an awesome job at responding.

April training was held on April 19<sup>th</sup>, and it focused on trench rescue training. The was the first out of 3 mandatory drills we host each year. We had two instructors from Cedar Rapids Fire come down to teach the refresher course. Nearly every member was in attendance. There were 2 structure fires in April in our district. One was at 2675 230<sup>th</sup> Street which was caused by a brush pile smoldering. The second was at 2670 Red Oak Avenue and was caused by an electrical malfunction. Both buildings suffered significant damage. Washington also responded to 6 mutual aid calls in April. Three of those mutual aid calls were to other departments for structure fire. April was a very busy month.

I attended numerous staff meetings and fire meetings. I am continuing to update our standard operating guidelines. Full time staff continues to be busy responding to EMS & fire calls, fire inspections, rental inspections, and normal duties around the fire station.

Washington Fire/EMS assisted the police department at the Kewash ½ marathon and all went well. Five members attended Stewart School to support their community leader day. One of them wore our dog suit costume. The kids loved it. It is great to get out and support our school district and future generations. We will continue to promote outreach in our community through various events.

We are here and ready to respond.



Brendan S. DeLong  
Fire Chief  
Washington Fire Department

### January – April 2023 Calls for service

Fire/Rescue calls - 61  
Medical calls – 252  
Total calls - 313

# MAINTENANCE & CONSTRUCTION DEPT. REPORT

4-15-23/4-28-23

**STREETS:** Personnel poured 7 yards of concrete on West Buchanan St. The street sweeper made its normal round. Personnel cold mixed areas of the town using 3,500 lbs. East 4th St and the entrance to the WWTP received dust control products (Calcium/Chloride).

**WATER DISTRIBUTION:** Personnel repaired a water shut off located at 1525 North Marion Ave (replaced rod). Personnel replaced an entire lead service line from the shut off to the water main, and replaced the shut off valve located at 407 South 2nd Ave. Personnel replaced the entire water service located at 731 South Marion Ave. Personnel had 4 water services for nonpayment. Cornerstone began installing an 8 inch water main, and City personnel assisted on a few issues they ran into.

**SEWER COLLECTION:** Personnel flushed terminal manholes and trouble spots using 17,000 gallons of water. Personnel also jetted numerous locations (1,155 ft) such as north of Van Buren from Perdock Ct & South 10th Ave and East Main from 3rd Ave to 4th Ave using 4,500 gallons of water.

**STORM SEWER COLLECTION:** Personnel N/A

**MECHANIC/SHOP:** Personnel serviced 119 (air horn & replaced air valve), PD TrailBlazer (replaced headlight), 111 (switched to summer tires), PD Speed trailer, 611, brush mower (mounted quick attach), showed new personnel on quick attachments for end loader, assisted with Cemetery (3 holes & repaired mower) and 113 tractor.

**OTHER:** Personnel hauled numerous rock and sand back to the material storage building. Personnel responded to 71 One Call Locates. Personnel assisted with the spring clean up process. Personnel also assisted with the

annual Kewash 5K, 10K & Half Marathon installing signage and placing cones and barricades in designated areas. Yard Waste pick up routes continued.

\*Please note that this report does not include every task M/C personnel performed, but shall be a highlight of our work performed as a department.



# Washington Police Department

James Lester, Chief of Police

215 East Washington Street

Washington, Iowa 52353

Phone: 319-653-2256 Dispatch: 319-653-2107

## Activity Report April 2023

Rhonda Hill  
Administrative Assistant

Lyle Hansen  
Lieutenant

Shamus Altenhofen  
Lieutenant

Jason Chalupa  
Sergeant

Benjamin Altenhofen  
Sergeant

Brian VanWilligen  
Investigator

Eric Kephart  
K-9 Handler

Seth Adam  
Police Officer

Tanner Lavelly  
Police Officer

Mia Brdecka  
Police Officer

Colton Schneider  
Police Officer

Officers were invited to two events at Stewart Elementary School in April. Officer Kephart and K-9 Dex joined Lt. Hansen at the school's walk-a-thon event and Lt. Hansen, Sgt. Chalupa, Officer Kephart and K-9 Dex and Officer Brdecka participated in the Community Helpers event interacting with students before their school day started.

Officer Adam attended the Iowa Department of Public Safety's two-week Law Enforcement Intelligence Network training. This is a specialized training that provides officers with real-life training in surveillance and intelligence gathering along with reporting and case management.

Chief Lester attended the Iowa Attorney General's Sexual Assault Response Conference and also served as a reader at the Iowa Department of Corrections' Victim Advisory Council Crime Victims' Rights Week Commemoration on April 27<sup>th</sup> in Des Moines that honored crime victims who died in the last year.

Respectfully submitted,

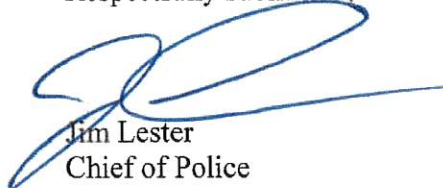

Jim Lester  
Chief of Police

# Washington Police Department

215 East Washington Street  
 Washington, Iowa 52353  
 Phone: 319-653-2256 Dispatch: 319-653-2107

## 2023 Activity & Offense Report For the Month of: April

ACTIVITY	Previous Month	Current Month	Year - to - Date
<b>Calls For Service</b>	<b>399</b>	<b>437</b>	<b>1502</b>
Animal Calls	19	34	69
Traffic Citations / Warnings	27	12	94
Parking Tickets	11	1	19
Golf Cart Registrations	1	5	15
Vehicle Unlocks	24	32	99
Arrest Warrants Served	5	6	27
Search Warrants Served	1	1	3
Mental Health Crisis	20	17	62
Traffic Stops	52	51	215
Traffic Accidents	17	9	50
Arrests	33	16	107
<b>Reportable Offenses</b>			
	<b>58</b>	<b>46</b>	<b>191</b>
Assault	8	3	21
Burglary	5	1	8
Burglary to Motor Vehicle	2	3	9
Domestic Assault	1	1	7
No Contact Order Violation	1	1	7
Criminal Mischief/Vandalism	6	8	24
Drunkenness (Intoxication)	1	2	5
Driving Intoxicated (OWI)	3	1	7
Drug Offense	2	0	11
Drug Paraphernalia	1	0	3
Harassment/Intimidation	3	1	15
Sex Offense	2	0	4
Theft (Includes Shoplifting)	9	16	37
Trespass	0	1	3
Weapons Violation	1	1	3

This chart indicates a summary of the activity and offenses the Washington Police Department responded to during the reporting period. Some activity/offense types have been combined to simplify reporting. It should be noted an offense does not always result in an arrest. Calls for service do not always include return phone calls, assistance to other agencies and instances where officers are approached while on patrol for minor issues or requests for assistance.

**WWTP report  
May 16th , 2023  
Council meeting**

- **After hour alarm and dog call outs –**  
4-30-2023 Dog call to 311 E Madison @ 11:30 p.m. Dylan  
5-9-2023 Dog call to 1103 E Washington @ 5:18 p.m. Dylan  
5-10-2023 Alarm at the WWTP @ 10:35 p.m. Parker and Dylan
  
- **Dept Head meetings –May 23<sup>rd</sup>**
  
- **Hydrogen Sulfide Gas-** We continue to have meetings and conference calls with IRE, NELCO, Fox eng., and City staff to resolve the issue. We did get four more hydrogen sulfide monitors for a total of seven. We have the monitors spread through the sewer system from IRE to the WWTP. We get readings from the monitors once a week, share and go over the information with everyone.
  
- **IAWEA Region-**Parker and I attended the annual IAWEA region 6 meeting in Iowa City on the 3<sup>rd</sup>.
  
- **Grit Pump-**The grit pump was plugged due to the epoxy paint coating peeling off the walls and covering the inlet pipe to the pump. I will be working on a proposal for fiscal year 2024-2025 to have the walls of the influent walls relined.
  
- **WWTP April 2023, Discharge Monitoring Report (DMR) –** Average daily flow 1.507 million gallons (mg), maximum daily flow 2.7 mg, minimum daily flow 1.11 mg. There were zero (0) violations of the WWTP's NPDES discharge permit. Total precipitation for April = >0.96" (recorded at the WWTP).

<b>CBOD5 removal 85% required</b>	<b>result = 97.2 %</b>
Influent CBOD5 monthly total =	<b>759.4 mg/L</b>
Effluent CBOD5 monthly total =	<b>21.18 mg/L</b>

<b>TSS removal 85% required</b>	<b>result =97.6%</b>
Influent TSS monthly total =	<b>1097 mg/L</b>
Effluent TSS monthly total =	<b>26.56 mg/L</b>

The Plant is Required 85% removal of both CBOD aTSS.

**\*Due to all Effluent samples being under detection levels the results are counted as 0**

**Jason Whisler  
5/12/2023 10:20 A.M.**

Here is a summary of the updates and activities from the Water Treatment Department for April, 2023.

**Water Plant Operations:** I submitted our March MOR to the DNR. We read water meters, book 7, our monthly extra meter list, all unread meters, and re-reads. We changed 8 water meters in April. We continue to work on changing dead meters. Delong installed the new golf course meter and we attached a radio box to it. We collected routine monthly bacteria samples and the results were absent. Our bulk chemicals were filled up. The plant was sprayed for bugs. We recorded our monthly well levels. We changed bag filters and cartridge filters on RO 2. We also cleaned the bag filter vessels. Ace Electric serviced our generator, we need to order diesel fuel for it. Electric Pump serviced all of our pumps and motors. Alliant Energy installed a new gas meter at well 5. We had 3 shut offs this month and all are back on. Washington Electric got conduits sealed up at both wells 6 & 7. I took pictures and emailed them to the DNR. Keith and a IAMU safety rep performed a noise study on the water plant. We replaced a leaky valve on RO2. We cleaned and fixed a small leak on the RO1 air release valve. RO3 was causing us issues and we trouble shot it to determine the concentrate valve was not operating correctly. We manually positioned the valve at a set position to where it is operating correctly but need to have it fixed. Jetco came down and got well 7 communicating correctly. They also determined well 5 motor was no good.

**Well 5:** As you are all aware, well 5 motor is no good. We determined at the council meeting last month that we will have Peerless Well and Pump pull the pump and motor. This work should be done in the next couple weeks. I have notified the DNR and they may stop by and observe some the work. I will keep you posted on the project.

**Street Lights:** The lights on the square have been working like they should be for a few weeks now. Fixing the 2 exposed panels must have fixed the problem by keeping moisture out. Mike Zehr with Washington Electric assisted us in locating underground wires at the Walmart intersection. Franzen Electric took down the street light in front of the new Marion Baptist Church building. It is currently being stored at the well 7 lot. It will get relocated and installed when the church is done with the brick work to the building. Marion Baptist Church is paying for this.

**Operators:** Will and I both split up weekend duties evenly. We both try to carry the on-call phone evenly. We have been called out multiple times this month from power outages or power surges from the storms.

**Meetings attended:** Weekly staff meetings, council meeting for well 5 proposal, 1 on 1 with Deanna, Lead service line meeting, 2 GIS meetings, meeting with Deanna and the Golf Course reps about water metering and met with Adam from IRWA about equipment. I also gave a tour of the water plant to Deanna and a few council members.

If you have any questions or concerns, please do not hesitate to contact myself or Will.

Thanks, stay safe!

Kyle Wellington

Water Treatment Superintendent



**CITY OF WASHINGTON, IOWA  
CLAIMS REPORT  
MAY 16, 2023**

<b>POLICE</b>	ACE-N-MORE	SUPPLIES/TRAINING MATERIALS	496.44
	AMAZON CAPITAL SERVICES	SUPPLIES	211.36
	ARNOLD MOTOR SUPPLY	DURANGO REPAIR	346.52
	BDH TECHNOLOGY LLC	IT SERVICES	571.00
	GALLS LLC	BOOTS - HANSEN	131.71
	HY VEE CATERING	ILEA MEALS/ SCHNEIDER	2,361.52
	IOWA LAW ENFORCMT ACADEMY	NEW HIRE TESTING	150.00
	IOWA POLICE CHIEFS ASSOCIATION	TRAINING-S ALTENHOFEN	50.00
	IOWA PRISON INDUSTRIES	ILEA UNIFORMS-SCHNEIDER	230.00
	KCTC	PHONE & INTERNET	232.70
	OMG NATIONAL	SUPPLIES	615.28
	SECTOR	BODY CAM MOUNTING CLIPS	219.00
	STOP STICK LTD.	HOLSTER & STOP STICK KIT	729.00
	VERIZON WIRELESS	WIRELESS SERVICE	966.97
	WASH CO TREASURER	STOP ON REG FEES	10.00
	WMPF GROUP LLC	LEGAL NTC-BICYCLES	34.51
		<b>TOTAL</b>	<b>7,356.01</b>
<b>FIRE</b>	ACE-N-MORE	ROOF REPAIR/SUPPLIES	124.91
	ALL AMERICAN PEST CONTROL	PEST CONTROL	32.50
	BEAUCHAMP, TOM	MILEAGE REIMBURSEMENT	149.34
	CENTRAL IOWA DISTRIBUTING	SUPPLIES	240.00
	DELONG, BRENDAN	CONF MILEAGE REIMB	438.77
	GALLS LLC	SHIRT	23.28
	HOTSY CLEANING SYSTEMS	SERVICE	892.23
	KCTC	PHONE & INTERNET	191.32
	SUMMIT FIRE PROTECTION	EXTINGUISHER SERVICE	329.25
	VERIZON WIRELESS	WIRELESS SERVICE	120.03
		<b>TOTAL</b>	<b>2,541.63</b>
	<b>DEVELOPMENT SERVICES</b>	VERIZON WIRELESS	WIRELESS SERVICE
		<b>TOTAL</b>	<b>178.91</b>
<b>LIBRARY</b>	ACE-N-MORE	JANITORIAL SUPPLIES	16.58
	ALL AMERICAN PEST CONTROL	PEST CONTROL	40.00
	ALLIANT ENERGY	ALLIANT ENERGY	1,077.67
	AMAZON CAPITAL SERVICES	LIBRARY MATERIALS	96.90
	CINTAS CORP LOC. 342	MAT SERVICE	84.57
	COLUMBUS GAZETTE	NEWSPAPER SUBSCRIPTION	41.00
	DEMCO INC	PROGRAM SUPPLIES	123.63
	KCI	PROGRAM PROMOTION	123.76
	KCTC	PHONE & INTERNET	406.76
		<b>TOTAL</b>	<b>2,010.87</b>
	<b>PARKS</b>	ALLIANT ENERGY	ALLIANT ENERGY
ACE-N-MORE		FERTILIZER/REPAIR/SUPPLIES	309.70
KCTC		PHONE & INTERNET	340.32
		<b>TOTAL</b>	<b>1,899.22</b>
<b>POOL</b>	ALLIANT ENERGY	ALLIANT ENERGY	91.10
	KCTC	PHONE & INTERNET	85.94
		<b>TOTAL</b>	<b>177.04</b>

<b>CEMETERY</b>	ACE-N-MORE	SUPPLIES	512.41	
	KCTC	PHONE & INTERNET	120.39	
	MOWERS PLUS	STARTER/TRANSMISSION OIL	217.50	
		<b>TOTAL</b>	<b>850.30</b>	
<b>FINAN ADMIN</b>	ACCESS SYSTEMS	COPIER MAINTENANCE & COPIE	806.13	
	ACE-N-MORE	SUPPLIES	34.54	
	ALBERT, KIRK	MILEAGE REIMBURSEMENT	103.49	
	ALL AMERICAN PEST CONTROL	PEST CONTROL	32.50	
	ALLIANT ENERGY	ALLIANT ENERGY	36.67	
	CENTRAL IOWA DISTRIBUTING	SUPPLIES	144.00	
	GOOGLE LLC	EMAIL SUBSCRIPTION	396.00	
	HOLIDAY INN	LODGING FOR CONFERENCE	224.00	
	KCII	ADVERTISING	282.88	
	KCTC	PHONE & INTERNET	1,147.83	
	STATE OF IOWA	FY22-AUDIT FILING FEE- ADD	200.00	
	VERIZON WIRELESS	WIRELESS SERVICE	127.61	
	WASH COUNTY MINIBUS	LOST- MAY	15,175.51	
	WMPF GROUP LLC	LEGAL NOTICE	809.56	
		<b>TOTAL</b>	<b>19,520.72</b>	
	<b>AIRPORT</b>	ACE-N-MORE	SUPPLIES	98.69
		BAUTISTA MIRANDA, YOLANDA	APRIL CLEANING	300.00
KCII		ADVERTISING	106.08	
TITAN AVIATION FUELS		PARTS FOR FUEL SYSTEM	282.47	
VERIZON WIRELESS		WIRELESS SERVICE	46.30	
WEST LAWN CARE		AIRPORT MOWING	1,510.00	
WINDSTREAM IOWA COMMUNICATIONS		MAY SERVICE	194.92	
		<b>TOTAL</b>	<b>2,538.46</b>	
<b>ROAD USE</b>		ACE-N-MORE	MAIL BOX REPAIR/SUPPLIES	185.52
		APPLIED INDUSTRIAL TECHNOLOGIES	DRILL BITS	494.83
	ARNOLD MOTOR SUPPLY	HOSE REPAIR/TAHOE PARTS	328.59	
	BINNS & STEVENS EXPLOSIVES INC	DUST CONTROL	526.40	
	CHEMSEARCH FE	SUPPLIES	561.90	
	COBB OIL CO., INC-BP ONE TRIP	FUEL	145.73	
	DOUDS STONE LLC	ROADSTONE	1,287.08	
	HI-LINE INC	SHOP EQUIPMENT	104.54	
	IDEAL READY MIX	DRIVEWAY/ W BUCHANAN	635.63	
	MICHAEL TODD & COMPANY	BROOM W/SCRAPER	78.67	
	SCHNEIDER GEOSPATIAL, LLC	GIS MAPPING	3,066.66	
	THOMPSON TRUCK AND TRAILER INC.	BATTERIES	586.67	
	WMPF GROUP LLC	LEGAL NTC	13.11	
		<b>TOTAL</b>	<b>8,015.33</b>	
<b>STREET LIGHTING</b>	ALLIANT ENERGY	ALLIANT ENERGY	11,852.60	
	MARIE ELECTRIC INC.	BULB INSTALLATION	410.94	
		<b>TOTAL</b>	<b>12,263.54</b>	
<b>CAPITAL PROJECTS</b>	KULL, LEONARD AND NANCY	LIGHTING RELOCATION	500.00	
		<b>TOTAL</b>	<b>500.00</b>	
<b>INDUSTRIAL DEVELOP</b>	WEDG	WEDGE SHARE-915 W TYLER	4,298.88	
		<b>TOTAL</b>	<b>4,298.88</b>	

<b>TREE COMMITTEE</b>	IGRAPHIX, INC	TREE PLANTING BOOKLETS	380.00
	MCCONNELL, MARDE	SUPPLIES & BOOKLET SUPPLIE	59.90
		<b>TOTAL</b>	<b>439.90</b>
<b>POLICE FORFEITURE</b>	BDH TECHNOLOGY LLC	LAPTOP FOR ILEA	1,205.58
	IOWA DEPT OF JUSTICE	SPSC021995-FORFEITURE FUND	28.77
	WASHINGTON COUNTY ATTORNEY	FORFEITURE ORDER	12.95
		<b>TOTAL</b>	<b>1,247.30</b>
<b>LIBRARY GIFT</b>	BAKER & TAYLOR	LIBRARY MATERIALS	934.72
	LIBRARY FURNITURE INERNATIONAL, INC	SHELVING	1,885.00
	OVERDRIVE, INC.	DIGITAL MATERIALS	368.96
		<b>TOTAL</b>	<b>3,188.68</b>
<b>WATER PLANT</b>	ALL AMERICAN PEST CONTROL	PEST CONTROL	35.00
	ALLIANT ENERGY	ALLIANT ENERGY	15,370.74
	SIMMONS, RUDOLPH	WATER DEPOSIT REFUND	114.56
	ADAM, MARY JUNE	WATER DEPOSIT REFUND	41.65
	CRISWELL, LAINEY	WATER DEPOSIT REFUND	120.73
	DONALDSON, DENNIS H	WATER DEPOSIT REFUND	30.67
	SEE, RON & JULIE	WATER DEPOSIT REFUND	98.31
	SCHNICKER, MELINDA	WATER DEPOSIT REFUND	24.44
	ELECTRIC PUMP	SERVICE AGREEMENT	2,181.94
	KCTC	PHONE & INTERNET	158.67
	IA DEPT OF REVENUE	WET TAX	7,233.96
	ACE ELECTRIC. INC	SERVICE	311.50
	VERIZON WIRELESS	WIRELESS SERVICE	46.30
	PINNACLE ENGINEERING	VALVES & CHEMICAL LINE	744.59
	GLOBAL PAYMENTS	DC/CC ADMIN FEES	3,036.37
		<b>TOTAL</b>	<b>29,549.43</b>
	<b>WATER DISTRIBUTION</b>	ALLIANT ENERGY	ALLIANT ENERGY
ACE-N-MORE		SUPPLIES	539.88
BELL, JUSTIN J		BOOT REIMBURSMET	100.00
CUSTOM IMPRESSIONS INC		SAFETY WEAR	691.12
GILLUND ENTERPRISES		FUEL INJECTOR CLEANER	464.80
KCTC		PHONE & INTERNET	104.31
MIDWEST WHEEL		DUMP TRUCK R EPAIR	50.61
SAMO, BENJAMIN		BOOT REIMBURSEMENT	100.00
SCHIMBERG CO.		REPAIR & SUPPLIES	6,176.52
SCHNEIDER GEOSPATIAL, LLC		GIS MAPPING	3,066.67
UTILITY EQUIPMENT CO		CORNERSTONE- GATE VALVES	7,590.00
VERIZON WIRELESS		WIRELESS SERVICE	84.35
WASHINGTON RENTAL		CHAINS AW SHARPENING	64.36
		<b>TOTAL</b>	<b>19,061.71</b>
<b>SEWER PLANT</b>		ACE-N-MORE	SUPPLIES
	ALLIANT ENERGY	ALLIANT ENERGY	566.16
	COURTESY DOOR SALES & SER	OVERHEAD DOOR MAINTENANCE	120.00
	EUROFINS ENVIRONMENT TESTING NC	CERTIFIED TESTING	1,652.08
	IA DEPT OF REVENUE	SALES TAX	2,001.67
	IGRAPHIX, INC	SHIPPING/SUPPLIES	79.79
	KCTC	PHONE & INTERNET	197.67
	VERIZON WIRELESS	WIRELESS SERVICE	133.90
	WASHINGTON DISCOUNT TIRE	REPAIR	33.87
	WINDSTREAM IOWA COMMUNICATIONS	MAY SERVICE	56.96

		<b>TOTAL</b>	<b>4,884.44</b>
<b>SEWER COLLECTION</b>	ALLIANT ENERGY	ALLIANT ENERGY	1,082.56
	ACE-N-MORE	SUPPLIES	59.94
	KCTC	PHONE & INTERNET	104.31
	SCHNEIDER GEOSPATIAL, LLC	GIS MAPPING	3,066.67
	USA BLUEBOOK	EYE PROTECTION	414.25
	VERIZON WIRELESS	WIRELESS SERVICE	92.60
	WELLINGTON, EARL	BALL JOINT PRESS MASTER SE	775.00
		<b>TOTAL</b>	<b>5,595.33</b>
<b>SANITATION</b>	MIDWEST COMPUTER BROKERS	E-WASTE- CLEANUP	574.40
		<b>TOTAL</b>	<b>574.40</b>
<b>SELF INSURANCE</b>	EMPLOYEE BENEFIT SYSTEMS	EBS ADMIN FEE	341.53
		<b>TOTAL</b>	<b>341.53</b>
		<b>TOTAL</b>	<b>127,033.63</b>

**CITY OF WASHINGTON, IOWA  
MONTH TO DATE TREASURERS REPORT  
APRIL 30, 2023**

FUND	4/1/2023			4/30/2023		
	BEGINNING CASH BALANCE	M-T-D REVENUES	REVENUES NOT YET RECEIVED	M-T-D EXPENDITURES	EXPENSES NOT YET EXPENDED	ENDING CASH BALANCE
001-GENERAL FUND	685,700.60	1,122,975.85	-	264,967.18	-	1,543,709.27
002-AIRPORT FUND	393,434.23	44,418.64	-	39,118.12	-	398,734.75
010-CHAMBER REIMBURSEMENT	4,295.23	8,163.55	-	11,588.10	-	870.68
011-MAIN STREET REIMBURSEMENT	6,577.31	7,223.84	-	4,176.49	-	9,624.66
012-WEDG REIMBURSEMENT	2,194.82	8,835.35	-	8,005.94	-	3,024.23
050-DOWNTOWN INCENTIVE GRANT	131,473.15	-	-	-	-	131,473.15
110-ROAD USE	659,178.57	94,064.55	-	51,954.04	-	701,289.08
112-EMPLOYEE BENEFITS	-	299,325.39	-	299,325.39	-	-
113-LIABILITY INSURANCE	-	-	-	-	-	-
114-EMERGENCY LEVY	-	24,145.57	-	24,145.57	-	-
121-LOCAL OPTION SALES TAX	-	60,702.04	-	60,702.04	-	-
122-LOST DEBT SERVICE	129,895.00	-	-	-	-	129,895.00
123-LOST DEBT SERVICE RESERVE	79,170.00	-	-	-	-	79,170.00
124-HOTEL/MOTEL TAX	164,351.06	-	-	6,268.40	-	158,082.66
125-UNIF COMM UR-NE IND	30,017.22	10,485.10	-	-	-	40,502.32
126-SE RES UR	-	-	-	-	-	-
127-UNIF COMM UR - BRIARWOOD	21,965.01	-	-	21,965.01	-	-
128-URBAN RENEWAL AREA #3B/D	-	-	-	-	-	-
129-SC RES UR	8,934.41	25,340.57	-	-	-	34,274.98
130-URBAN RENEWAL AREA #3D	-	-	-	-	-	-
131-URBAN RENEWAL AREA #4	-	-	-	-	-	-
132-UNIF COMM UR - EBD	20,987.46	23,097.58	-	-	-	44,085.04
133-UNIF COMM UR-IRE	53,951.72	54,733.72	-	-	-	108,685.44
134-DOWNTOWN COMM UR	91,889.65	60,306.39	-	-	-	152,196.04
145-HOUSING REHABILITATION	54,710.32	-	-	-	-	54,710.32
146-LMI TIF SET-ASIDE	167,188.44	-	-	-	-	167,188.44
200-DEBT SERVICE	459,503.54	358,020.75	-	1,200.00	-	816,324.29
300-CAPITAL EQUIPMENT	83,846.34	30,567.45	-	-	-	114,413.79
301-CAPITAL PROJECTS FUND	1,568,366.88	14,850.71	-	6,384.62	-	1,576,832.97
303-WWTP CAPITAL PROJ FUND	-	-	-	-	-	-
305-RIVERBOAT FOUND CAP PROJ	888,122.18	-	-	-	-	888,122.18
308-INDUSTRIAL DEVELOPMENT	370,078.11	9,165.88	-	11,749.08	-	367,494.91
309-MUNICIPAL BUILDING	-	-	-	-	-	-
310-WELLNESS PARK	3,420.95	250.00	-	-	-	3,670.95
311-SIDEWALK REPAIR & REPLACE	87,109.86	828.00	-	-	-	87,937.86
312-TREE REMOVAL & REPLACE	15,948.59	-	-	-	-	15,948.59
315-RESIDENTIAL DEVELOPMENT	607,274.23	157.84	-	823.00	-	606,609.07
317-ARPA CAPITAL PROJECTS	993,398.54	2,576.36	-	-	-	995,974.90
325-BUILDING & FACILITY MAINT	13,524.60	-	-	-	-	13,524.60
510-MUNICIPAL BAND	8,083.03	-	-	-	-	8,083.03
520-DOG PARK	4,178.88	-	-	-	-	4,178.88
530-TREE COMMITTEE	18,149.58	3,873.00	-	600.96	-	21,421.62
535-NEIGHBORHOOD PRIDE	-	-	-	-	-	-
540-POLICE FORFEITURE	4,590.86	-	-	-	-	4,590.86
541-K-9 PROGRAM	2,236.66	30.00	-	200.44	-	2,066.22
545-SAFETY FUND	3,336.89	-	-	-	-	3,336.89
550-PARK GIFT	51,712.05	98.35	-	-	-	51,810.40
570-LIBRARY GIFT	355,309.26	1,526.11	-	10,913.01	-	345,922.36
580-CEMETERY GIFT	2,078.00	-	-	-	-	2,078.00
590-CABLE COMMISSION	-	-	-	-	-	-
600-WATER UTILITY	822,207.90	147,293.35	-	105,511.64	-	863,989.61
601-WATER DEPOSIT FUND	31,470.00	1,950.00	-	1,050.00	-	32,370.00
602-WATER SINKING	-	-	-	-	-	-
603-WATER CAPITAL PROJECTS	-	-	-	-	-	-
610-SANITARY SEWER	847,107.18	187,213.56	-	82,171.65	-	952,149.09
612-SEWER SINKING	-	-	-	-	-	-
613-SEWER CAPITAL PROJECTS	-	-	-	-	-	-
670-SANITATION	109,329.50	53,998.92	-	48,910.50	-	114,417.92
910-LIBRARY TRUST	-	-	-	-	-	-
950-SELF INSURANCE	485,410.60	31,944.95	-	5,503.28	-	511,852.27
951-UNEMPLOYMENT SELF INS	72,820.29	1,908.75	-	8,952.01	-	65,777.03
<b>TOTAL BALANCE</b>	<b>10,614,528.70</b>	<b>2,690,072.12</b>	<b>-</b>	<b>1,076,186.47</b>	<b>-</b>	<b>12,228,414.35</b>

**Cash in Bank - Pooled Cash**

		Interest Rate
Wash St. Bank - Operating Account	5,953,537.92 (1)	0.20%
Wash St. Bank - Airport Fuel Account	-	-
Cash in Drawer	350.00	N/A
Investment in IPAIT	591,339.42	0.20%
Wash St - Farm Mgmt Acct	201,099.74	-
Wash St Bank - CD 1/14/2019	524,077.42	0.65%
Wash St Bank - CD 08/30/2018	269,993.92	0.65%
Wash St Bank - ISC Account	4,708,015.93	4.00%
<b>TOTAL CASH IN BANK</b>	<b>12,248,414.35</b>	

(1) Washington State Bank  
Outstanding Deposits & Checks/Wages payable  
6,054,619.22  
(101,081.30)  
5,953,537.92

CITY OF WASHINGTON, IOWA  
YEAR TO DATE TREASURERS REPORT  
APRIL 30, 2023

FUND	7/1/2022 BEGINNING CASH BALANCE	Y-T-D REVENUES	REVENUES NOT YET RECEIVED	Y-T-D EXPENDITURES	EXPENSES NOT YET EXPENDED	4/30/2023 ENDING CASH BALANCE
001-GENERAL FUND	1,022,613.53	4,026,113.32	-	3,505,017.58	-	1,543,709.27
002-AIRPORT FUND	358,953.40	333,547.11	-	293,765.76	-	398,734.75
010-CHAMBER REIMBURSEMENT	7,902.24	128,443.56	-	135,475.12	-	870.68
011-MAIN STREET REIMBURSEMENT	2,118.03	44,715.06	-	37,208.43	-	9,624.66
012-WEDG REIMBURSEMENT	2,584.82	83,706.32	-	83,266.91	-	3,024.23
050-DOWNTOWN INCENTIVE GRANT	163,473.15	-	-	32,000.00	-	131,473.15
110-ROAD USE	504,763.55	844,382.34	-	647,856.81	-	701,289.08
112-EMPLOYEE BENEFITS	-	810,517.90	-	810,517.90	-	-
113-LIABILITY INSURANCE	-	-	-	-	-	-
114-EMERGENCY LEVY	-	65,422.74	-	65,422.74	-	-
121-LOCAL OPTION SALES TAX	-	937,143.29	-	937,143.29	-	-
122-LOST DEBT SERVICE	-	154,790.00	-	24,895.00	-	129,895.00
123-LOST DEBT SERVICE RESERVE	79,170.00	-	-	-	-	79,170.00
124-HOTEL/MOTEL TAX	122,812.24	78,501.04	-	43,230.62	-	158,082.66
125-UNIF COMM UR-NE IND	-	40,502.32	-	-	-	40,502.32
126-SE RES UR	-	-	-	-	-	-
127-UNIF COMM UR - BRIARWOOD	-	43,930.02	-	43,930.02	-	-
128-URBAN RENEWAL AREA #3B/D	-	-	-	-	-	-
129-SC RES UR	-	79,253.31	-	44,978.33	-	34,274.98
130-URBAN RENEWAL AREA #3D	-	-	-	-	-	-
131-URBAN RENEWAL AREA #4	-	-	-	-	-	-
132-UNIF COMM UR - EBD	-	44,085.04	-	-	-	44,085.04
133-UNIF COMM UR-IRE	-	108,685.44	-	-	-	108,685.44
134-DOWNTOWN COMM UR	-	154,333.75	-	2,137.71	-	152,196.04
145-HOUSING REHABILITATION	35,643.82	161,544.00	-	142,477.50	-	54,710.32
146-LMI TIF SET-ASIDE	151,266.11	15,922.33	-	-	-	167,188.44
200-DEBT SERVICE	56,467.63	919,091.77	-	159,235.11	-	816,324.29
300-CAPITAL EQUIPMENT	147,053.70	43,192.38	-	75,832.29	-	114,413.79
301-CAPITAL PROJECTS FUND	437,301.66	5,369,681.82	-	4,230,150.51	-	1,576,832.97
303-WWTP CAPITAL PROJ FUND	-	-	-	-	-	-
305-RIVERBOAT FOUND CAP PROJ	398,997.29	489,124.89	-	-	-	888,122.18
308-INDUSTRIAL DEVELOPMENT	255,745.84	274,216.06	-	162,466.99	-	367,494.91
309-MUNICIPAL BUILDING	-	-	-	-	-	-
310-WELLNESS PARK	6,353.50	12,393.95	-	15,076.50	-	3,670.95
311-SIDEWALK REPAIR & REPLACE	90,642.86	3,471.00	-	6,176.00	-	87,937.86
312-TREE REMOVAL & REPLACE	23,988.59	-	-	8,040.00	-	15,948.59
315-RESIDENTIAL DEVELOPMENT	278,930.49	354,428.74	-	26,750.16	-	606,609.07
317-ARPA CAPITAL PROJECTS	523,763.25	562,048.65	-	89,837.00	-	995,974.90
325-BUILDING & FACILITY MAINT	13,524.60	-	-	-	-	13,524.60
510-MUNICIPAL BAND	4,743.03	3,340.00	-	-	-	8,083.03
520-DOG PARK	4,443.11	-	-	264.23	-	4,178.88
530-TREE COMMITTEE	11,322.84	11,723.00	-	1,624.22	-	21,421.62
535-NEIGHBORHOOD PRIDE	-	-	-	-	-	-
540-POLICE FORFEITURE	4,590.86	-	-	-	-	4,590.86
541-K-9 PROGRAM	2,809.30	650.00	-	1,393.08	-	2,066.22
545-SAFETY FUND	2,636.89	1,000.00	-	300.00	-	3,336.89
550-PARK GIFT	32,135.30	32,042.04	-	12,366.94	-	51,810.40
570-LIBRARY GIFT	354,318.68	30,597.61	-	38,993.93	-	345,922.36
580-CEMETERY GIFT	7,433.00	-	-	5,355.00	-	2,078.00
590-CABLE COMMISSION	-	-	-	-	-	-
600-WATER UTILITY	495,798.75	1,642,377.66	-	1,274,186.80	-	863,989.61
601-WATER DEPOSIT FUND	30,835.00	15,450.00	-	13,915.00	-	32,370.00
602-WATER SINKING	-	38,350.00	-	38,350.00	-	-
603-WATER CAPITAL PROJECTS	-	96,170.94	-	96,170.94	-	-
610-SANITARY SEWER	188,444.50	2,065,125.34	-	1,301,420.75	-	952,149.09
612-SEWER SINKING	-	114,852.50	-	114,852.50	-	-
613-SEWER CAPITAL PROJECTS	-	8,512.66	-	8,512.66	-	-
670-SANITATION	67,068.52	541,313.07	-	493,963.67	-	114,417.92
910-LIBRARY TRUST	-	-	-	-	-	-
950-SELF INSURANCE	463,148.16	86,331.38	-	37,627.27	-	511,852.27
951-UNEMPLOYMENT SELF INS	73,505.00	5,385.31	-	13,113.28	-	65,777.03
<b>TOTAL BALANCE</b>	<b>6,427,303.24</b>	<b>20,876,409.66</b>	<b>-</b>	<b>15,075,298.55</b>	<b>-</b>	<b>12,228,414.35</b>

Cash in Bank - Pooled Cash

		Interest Rate
Wash St. Bank - Operating Account	5,953,537.92 (1)	0.20%
Wash St. Bank - Airport Fuel Account	-	-
Cash in Drawer	350.00	N/A
Investment in IPAIT	591,339.42	0.20%
Wash St - Farm Mgmt Acct	201,099.74	-
Wash St Bank - CD 1/14/2019	524,077.42	0.65%
Wash St Bank - CD 08/30/2018	269,993.92	0.65%
Wash St Bank - ISC Account	4,708,015.93	4.00%
<b>TOTAL CASH IN BANK</b>	<b>12,248,414.35</b>	

(1) Washington State Bank  
Outstanding Deposits & Checks/Wages payable  
5,953,537.92

*Millie Youngquist, Mayor Pro Tem  
Sally Hart, City Clerk  
Kevin Olson, City Attorney  
Deanna McCusker, City Administrator*



*City of Washington  
215 East Washington Street  
Washington, Iowa 52353  
(319) 653-6584 Phone  
(319) 653-5273 Fax*

---

May 11, 2023

To: Mayor & City Council  
Cc: Sally Hart, City Clerk & Kelsey Brown, Finance Director

From: Deanna McCusker  
City Administrator

Re: 12<sup>th</sup> & Hwy 92 plans

Leland from VNK will be present at the council meeting Tuesday night to review updated plans for the traffic signals and the 4-3 lane conversion with cost estimates. The DOT is on board with the lane conversion. There is funding for both projects from the DOT, which is included in your materials. Safety has been a real concern with the lane conversion, but it is actually proven to be safer reducing the lanes, which Leland will discuss at the meeting.

Council will need to consider if we move forward with the 4-3 lane conversion as part of this overall project. I would suggest that we post this on our website for the public to weigh in on and also have councilors talk with people in their wards to get adequate feedback.

# WASHINGTON COUNTY

WORK TYPE  
PROJECT NUMBER

LETTING DATE  
11-21-2023

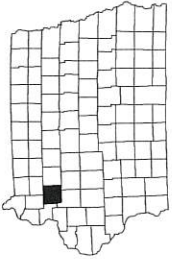
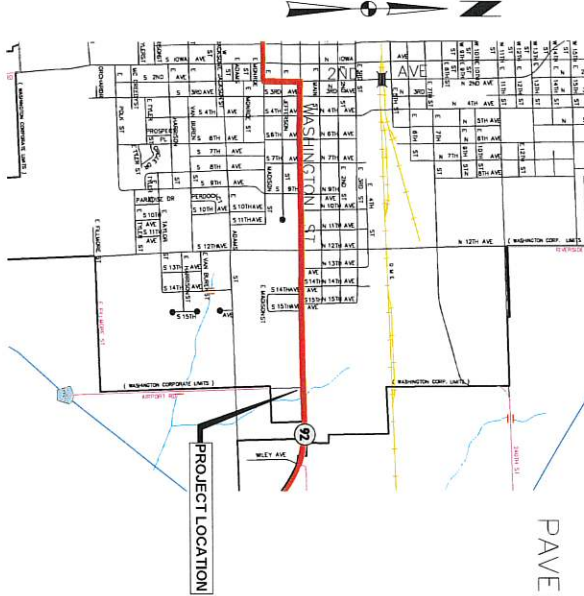

## CITY OF WASHINGTON

### PAVEMENT STRIPING AND SIGNALIZATION

HWY 92 FROM MADISON ST TO WILEY AVE

SCALE: As Noted

The Iowa Department of Transportation Standard Specifications for Highway and Bridge Construction and the Iowa Department of Transportation Supplemental Specifications and Special Provisions shall apply to construction work on this project.

Value Engineering Saves. Refer to Article 1105.15 of the Specifications

MILEAGE SUMMARY		105-1
Dist.	Location	09-27-94
1	STATION 185+70 TO STATION 267+50	1.55
TOTAL LENGTH OF PROJECT		8200
		1.55

04-30-02	101-5
DESIGN DATA URBAN	
2018 ADOT	8,500 V.P.D.
1998 ADOT	8,000 V.P.D.
2023 DMV	850 V.P.H.
TRUCKS	R %
Total Design ES&S	

REVISIONS	
PROJECT IDENTIFICATION NUMBER	XXXX-XX-X(XX)-XX-XX
PROJECT NUMBER	XXXX-XX-X(XX)-XX-XX
R.O.W. PROJECT NUMBER	XXXX-XX-X(XX)-XX-XX
TOTAL SHEETS	

No.	Description	105-3
A.01	The Sheet	10-18-05
B.01	Typical Cross Sections and Details	
C.01 - C.04	Quantities and General Information	
D.01 - D.02	Demolition Plan	
D.01 - D.02	Paving Plan	
G.01	Benchmarks and Control Points	
J.01	Traffic Control and Staging	
K.01 - K.08	Powerplant Marking Sheets	
L.01 - L.02	Intersection Geometry	
M.01 - M.05	Traffic Signal	

**PRELIMINARY PLANS**

I hereby certify that this engineering document was prepared by me or under my direct personal supervision and that I am a duly Licensed Professional Engineer in the State of Iowa.

Signature: [Blank] Date: [Blank]

Professional Seal: [Blank]

Project No. [Blank] Issue No. [Blank]

Project Name: [Blank]

Project Location: [Blank]

Project Date: [Blank]

Project Description: [Blank]



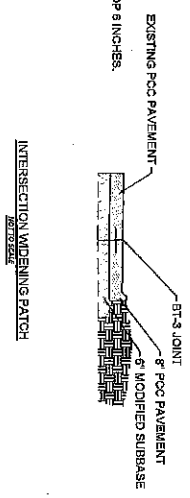
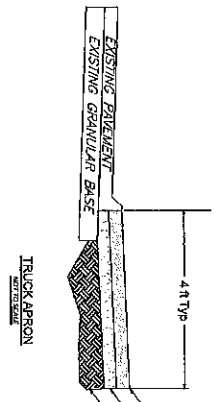
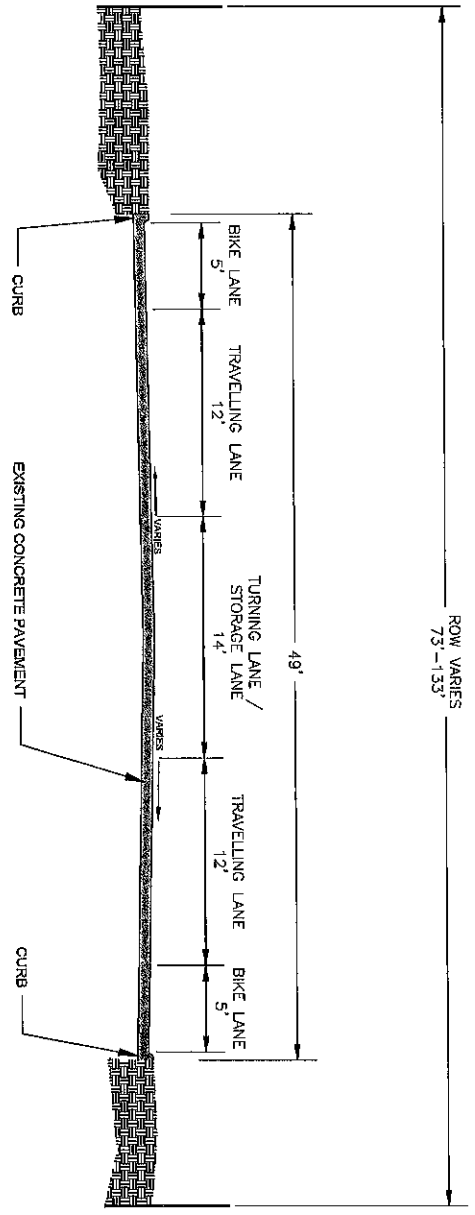

TYPICAL SECTION

ENGINEER	DATE	DESIGN TEAM	VEENSTRA & KIM, INC.	COUNTY	PROJECT NUMBER	SHEET NUMBER
WASHINGT	09/13/2022			WASHINGTON	VK 24653	B.01
						REVISED

ESTIMATED QUANTITIES					
ITEM NO.	ITEM CODE	ITEM	UNIT	TOTAL	AS BUILT QUAN.
1	2102-271030	EXCAVATION CL 18 ROW-40-ROW	CY	2686	
2	2102-271030	EXCAVATION CL 18 WASTE	CY	760	
3	2102-271030	TOPSOIL REMOVAL	CY	2810	
4	2102-271030	MOVED ASPHALT	TON	2800	
5	2102-271030	GRAVEL BASE 4" TYPE A	TON	4600	
6	2102-271030	BASE UNDERLAY 4" TYPE A	TON	1000	
7	2102-271030	1.5" HOT ASPHALT 1.5" CL. 3, 8"	TON	7200	
8	2102-271030	PAVING 1.5" TYPE A	TON	4600	
9	2102-271030	PAVING 1.5" TYPE A	TON	4600	
10	2102-271030	PAVING 1.5" TYPE A	TON	4600	
11	2102-271030	PAVING 1.5" TYPE A	TON	4600	
12	2102-271030	PAVING 1.5" TYPE A	TON	4600	
13	2102-271030	PAVING 1.5" TYPE A	TON	4600	
14	2102-271030	PAVING 1.5" TYPE A	TON	4600	
15	2102-271030	PAVING 1.5" TYPE A	TON	4600	
16	2102-271030	PAVING 1.5" TYPE A	TON	4600	
17	2102-271030	PAVING 1.5" TYPE A	TON	4600	
18	2102-271030	PAVING 1.5" TYPE A	TON	4600	
19	2102-271030	PAVING 1.5" TYPE A	TON	4600	
20	2102-271030	PAVING 1.5" TYPE A	TON	4600	
21	2102-271030	PAVING 1.5" TYPE A	TON	4600	
22	2102-271030	PAVING 1.5" TYPE A	TON	4600	
23	2102-271030	PAVING 1.5" TYPE A	TON	4600	
24	2102-271030	PAVING 1.5" TYPE A	TON	4600	
25	2102-271030	PAVING 1.5" TYPE A	TON	4600	
26	2102-271030	PAVING 1.5" TYPE A	TON	4600	
27	2102-271030	PAVING 1.5" TYPE A	TON	4600	
28	2102-271030	PAVING 1.5" TYPE A	TON	4600	
29	2102-271030	PAVING 1.5" TYPE A	TON	4600	
30	2102-271030	PAVING 1.5" TYPE A	TON	4600	
31	2102-271030	PAVING 1.5" TYPE A	TON	4600	
32	2102-271030	PAVING 1.5" TYPE A	TON	4600	
33	2102-271030	PAVING 1.5" TYPE A	TON	4600	
34	2102-271030	PAVING 1.5" TYPE A	TON	4600	
35	2102-271030	PAVING 1.5" TYPE A	TON	4600	
36	2102-271030	PAVING 1.5" TYPE A	TON	4600	
37	2102-271030	PAVING 1.5" TYPE A	TON	4600	

ESTIMATED QUANTITIES					
ITEM NO.	ITEM CODE	ITEM	UNIT	TOTAL	AS BUILT QUAN.
1	2102-271030	EXCAVATION CL 18 ROW-40-ROW	CY	2196	
2	2102-271030	EXCAVATION CL 18 WASTE	CY	540	
3	2102-271030	TOPSOIL REMOVAL	CY	760	
4	2102-271030	MOVED ASPHALT	TON	2800	
5	2102-271030	GRAVEL BASE 4" TYPE A	TON	4600	
6	2102-271030	BASE UNDERLAY 4" TYPE A	TON	1000	
7	2102-271030	1.5" HOT ASPHALT 1.5" CL. 3, 8"	TON	7200	
8	2102-271030	PAVING 1.5" TYPE A	TON	4600	
9	2102-271030	PAVING 1.5" TYPE A	TON	4600	
10	2102-271030	PAVING 1.5" TYPE A	TON	4600	
11	2102-271030	PAVING 1.5" TYPE A	TON	4600	
12	2102-271030	PAVING 1.5" TYPE A	TON	4600	
13	2102-271030	PAVING 1.5" TYPE A	TON	4600	
14	2102-271030	PAVING 1.5" TYPE A	TON	4600	
15	2102-271030	PAVING 1.5" TYPE A	TON	4600	
16	2102-271030	PAVING 1.5" TYPE A	TON	4600	
17	2102-271030	PAVING 1.5" TYPE A	TON	4600	
18	2102-271030	PAVING 1.5" TYPE A	TON	4600	
19	2102-271030	PAVING 1.5" TYPE A	TON	4600	
20	2102-271030	PAVING 1.5" TYPE A	TON	4600	
21	2102-271030	PAVING 1.5" TYPE A	TON	4600	
22	2102-271030	PAVING 1.5" TYPE A	TON	4600	
23	2102-271030	PAVING 1.5" TYPE A	TON	4600	
24	2102-271030	PAVING 1.5" TYPE A	TON	4600	
25	2102-271030	PAVING 1.5" TYPE A	TON	4600	
26	2102-271030	PAVING 1.5" TYPE A	TON	4600	
27	2102-271030	PAVING 1.5" TYPE A	TON	4600	
28	2102-271030	PAVING 1.5" TYPE A	TON	4600	
29	2102-271030	PAVING 1.5" TYPE A	TON	4600	
30	2102-271030	PAVING 1.5" TYPE A	TON	4600	
31	2102-271030	PAVING 1.5" TYPE A	TON	4600	
32	2102-271030	PAVING 1.5" TYPE A	TON	4600	
33	2102-271030	PAVING 1.5" TYPE A	TON	4600	
34	2102-271030	PAVING 1.5" TYPE A	TON	4600	
35	2102-271030	PAVING 1.5" TYPE A	TON	4600	
36	2102-271030	PAVING 1.5" TYPE A	TON	4600	
37	2102-271030	PAVING 1.5" TYPE A	TON	4600	

1004-10  
10-18-03

This project is for the 4 to 5 lane conversion of an urban section of HWY-482. Roadway widening, bike lanes, and ADA sidewalks will be updated where needed. Traffic signals to be installed at the 12th St intersection. Traffic will be maintained through HWY-482 at all times.

**TABULATION OF UTILITIES**

CITY OF WASHINGTON PUBLIC WORKS DIRECTOR	0000 XXXXXXX
WASHINGTON COUNTY SHERIFF EMERGENCY	0000 XXXXXXX 911
WASHINGTON POLICE DEPARTMENT	XXXX
WASHINGTON FIRE DEPARTMENT EMERGENCY	XXXX 911
VEENSTRA & KIMM, INC.-CORVALLIE IOWA ONE CALL	(818) 486-1000 800-325-8889

**STANDARD ROAD PLANS**

The following Standard Road Plans shall be considered applicable to construction work on this project.

Number	Date	Title
PL-270	10-03-78	
PL-271	04-21-78	Detectable Warnings and Pedestrian Ramp
PL-272	04-21-78	Line Types
PL-273	04-21-78	Symbols and Legends
PL-274	10-15-78	Two-Lane Roadway with Two-Way Left Turn Lane
PL-275	-	-
PL-276	-	-
PL-277	-	-
PL-278	-	-
PL-279	-	-
PL-280	-	-
PL-281	-	-
PL-282	-	-
PL-283	-	-
PL-284	-	-
PL-285	-	-
PL-286	-	-
PL-287	-	-
PL-288	-	-
PL-289	-	-
PL-290	-	-
PL-291	-	-
PL-292	-	-
PL-293	-	-
PL-294	-	-
PL-295	-	-
PL-296	-	-
PL-297	-	-
PL-298	-	-
PL-299	-	-
PL-300	-	-

105-4  
10-18-11

108-29  
04-21-15

TABULATION OF PAVEMENT MARKING SYMBOLS AND LEGENDS  
Refer to PM-111

ROAD IDENTIFICATION	STATION	SIDE	PAVEMENT MARKING SYMBOLS AND LEGENDS																REMARKS										
			STAY	RTAY	LTAY	CSRW	CSLW	CSRW	CSLW	FEW	LRW	RLRW	RRCW	BLSW	WCSW	WPSB	SCLW	XNGW		STPW	AHDW	ONLW	BRW	LANW	XITW	EAHW	GROVE CUTS		
	0+00	RT	↑	→	↪	↪	↪	↪	↪	↪	↪	↪	↪	↪	↪	↪	↪	↪	↪	↪	↪	↪	↪	↪	↪	↪	↪	↪	
TOTAL																													

108-22  
04-16-15

PAVEMENT MARKING LINE TYPES

BCV4 - Place on the same side of the roadway to match existing markings near the project  
 NPV4 - For estimating purposes only. No Passing Zone Lines will be located in the field.  
 BLV4 - Edge Line Left (Yellow) @ 1.00  
 DCV4 - Double Centerline (Yellow) @ 2.00  
 NPV4 - Factor of 1.00 as value includes number of 4-foot passes to cover median nose area.  
 BLV4 - Broken Lane Line (White) @ 1.25  
 ELV4 - Edge Line Right (White) @ 1.00

Road ID	Station to Station	Location	Dir of Travel	Marking Type	Side		Length by Line Type (in feet)																Remarks							
					L	R	BCV4	DCV4	NPV4	BLV4	ELV4	DLV4	CHV6	CHV8	LDV6	SFA	SFA	SFA	SFA	SFA	SFA	SFA								
0+00	0+00	EB	EB	HARBOND		X																								

TABULATION OF PAVEMENT MARKING SYMBOLS AND LEGENDS REMOVAL  
Refer to PM-111

ROAD IDENTIFICATION	LOCATION		SIDE	STATION	ST	STAV	RTAV	LTAV	GSRV	CSLV	CSTR	CRLV	FTRV	LRRV	ELRV	RRV	RORV	BLRV	WCRV	WPSV	SCLV	XCRV	STRV	AROV	ONLV	BRV	LANV	XTRV	GROOVE CUTS	REMARKS	
	STATION	SIDE																													
	0+00	ST				1																									
TOTAL																															

**PAVEMENT MARKING LINE TYPES REMOVAL**

\*\*\*ANY 4 - Factor of 1.00 as value includes number of 4-inch passes to cover median nose area.  
See PM-110

BCV4 - Place on the same side of the roadway to match existing markings near the project.  
 NPV4 - For estimating purposes only. No Passing Zone Lines will be located in the field.  
 ECV4 - Broken Centerline (Yellow) @ 0.25  
 DCV4 - Double Centerline (Yellow) @ 2.00  
 NPV4 - No Passing Zone Line (Yellow) @ 1.25  
 BLV4 - Broken Lane Line (White) @ 0.25  
 ELV4 - Edge Line Right (White) @ 1.00

Road ID	Station to Station	Location	Dir. of Travel	Marking Type	Side		BCV4		DCV4		NPV4		BLV4		ELV4		ELV4		DLV4		CLV4		STV4		ARV4		ONV4		BRV4		LANV		XTRV		GROOVE CUTS		REMARKS		
					L	R	STA	STA	STA	STA	STA	STA	STA	STA	STA	STA	STA	STA	STA	STA	STA	STA	STA	STA	STA	STA	STA	STA	STA	STA	STA	STA	STA	STA	STA	STA		STA	STA
82	0+00	0+00	EB																																				
Length by Line Type (Unfactored)																																							
Remarks																																							

TABULATIONS

108-29  
MODIFIED

108-22  
MODIFIED

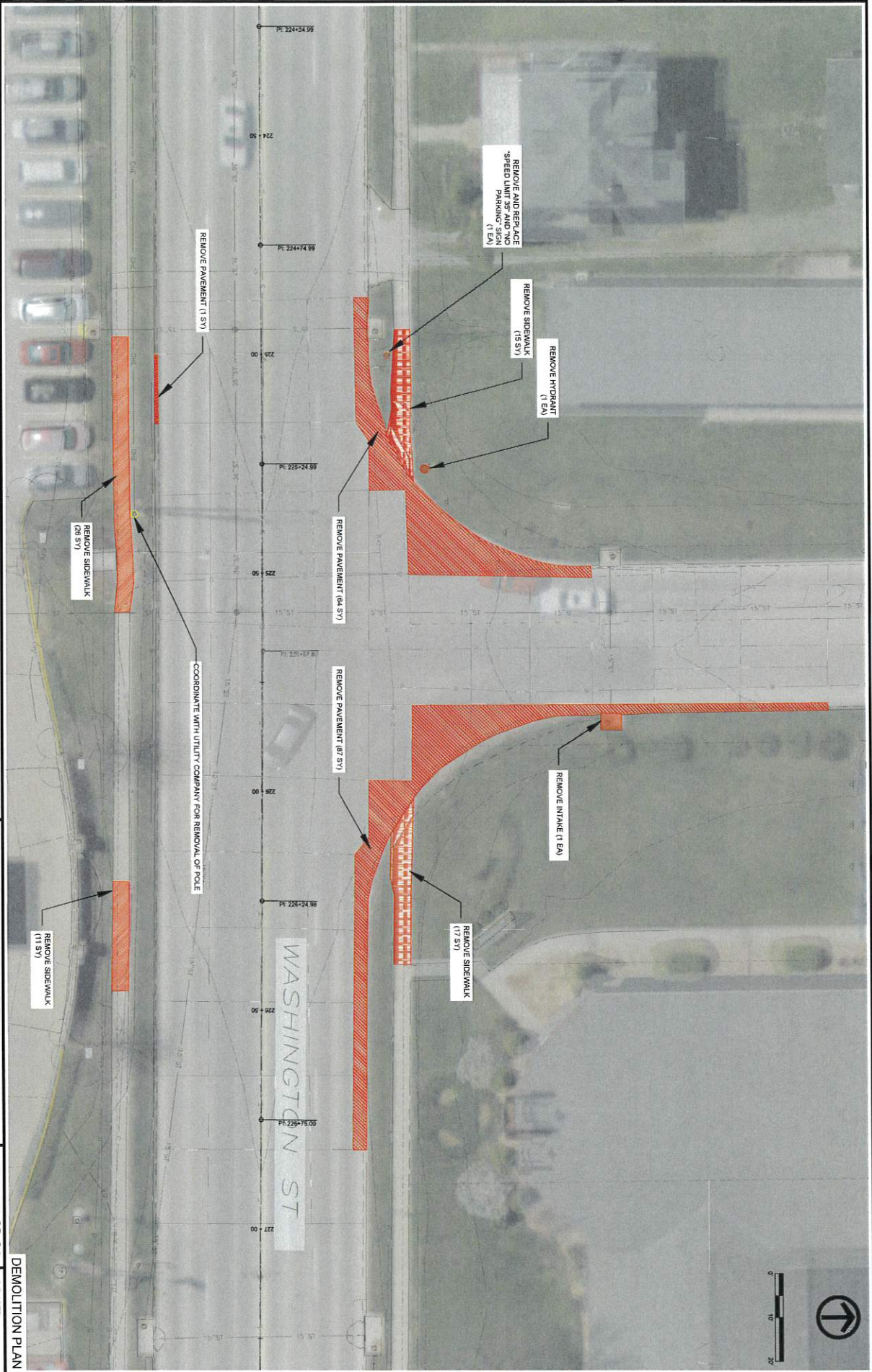

ENGLISH	09/11/2017	DESIGN TEAM	VEENSTRA & KIMM, INC.	WASHINGTON	COUNTY	PROJECT NUMBER	VK 24653	SHEET NUMBER	CD.01	REVISION	DEMOLITION PLAN
---------	------------	-------------	-----------------------	------------	--------	----------------	----------	--------------	-------	----------	-----------------



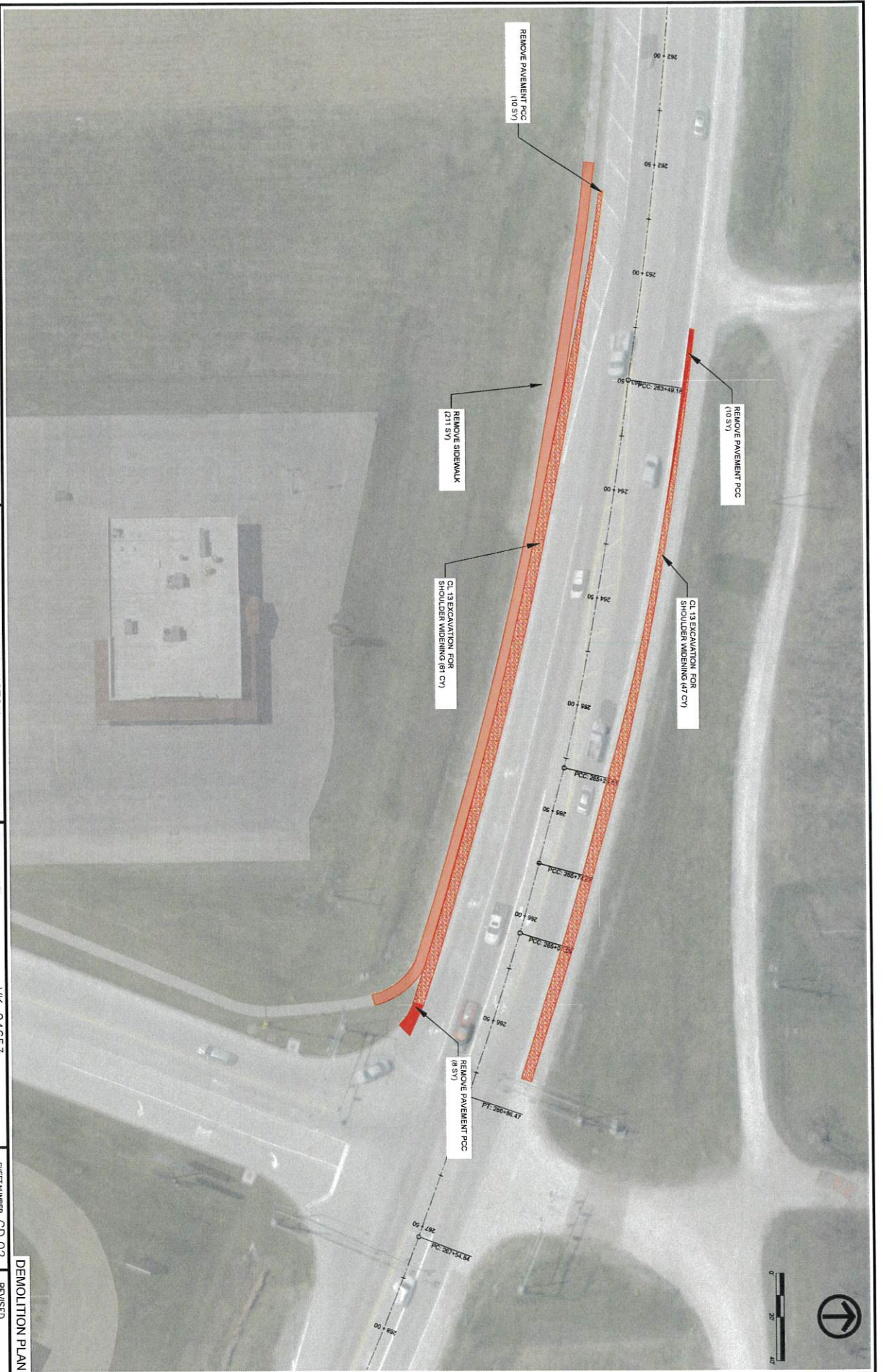

ENGLISH	09M 30T	DESIGN TEAM	VENSTRA & KIMM, INC.	WASHINGTON	COUNTY	PROJECT NUMBER	VK 24653	SHEET NUMBER	CD 02	REVISED
<small>           PLOTED: Tuesday, May 5, 2020 13:52:27 PM            FILE NAME: Z:\WORKSPACE\24653\1716 &amp; WASHCOUNT\INSPECTION\CD02\DEMOLITION_PLAN\CD02.VPNAME.dwg         </small>										

DEMOLITION PLAN

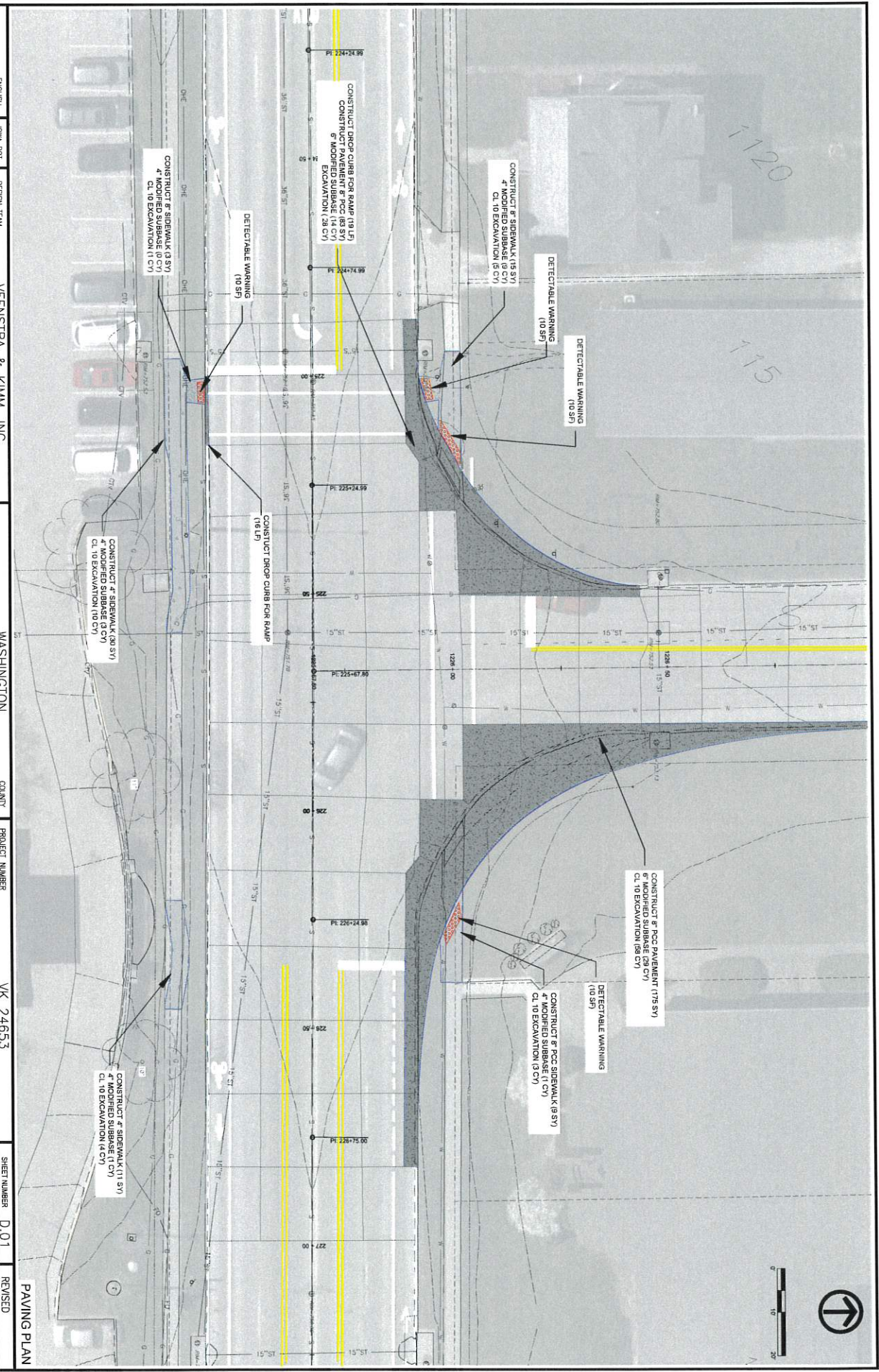

ENGLISH    DWG. DOT    DESIGN TEAM    VEENSTRA & KIMM, INC.    WASHINGTON    COUNTY    PROJECT NUMBER    VK 24653    SHEET NUMBER    D.01    PAVING PLAN    REVISED

CENTER LINE, STATION 8+30.00 TO 8+34.00  
 FILE PATH: E:\WORKSPACE\24653\24653.dwg    MODIFIED: 11/11/2015 10:45:11 AM    DESIGNED BY: S. HALL    CHECKED BY: S. HALL



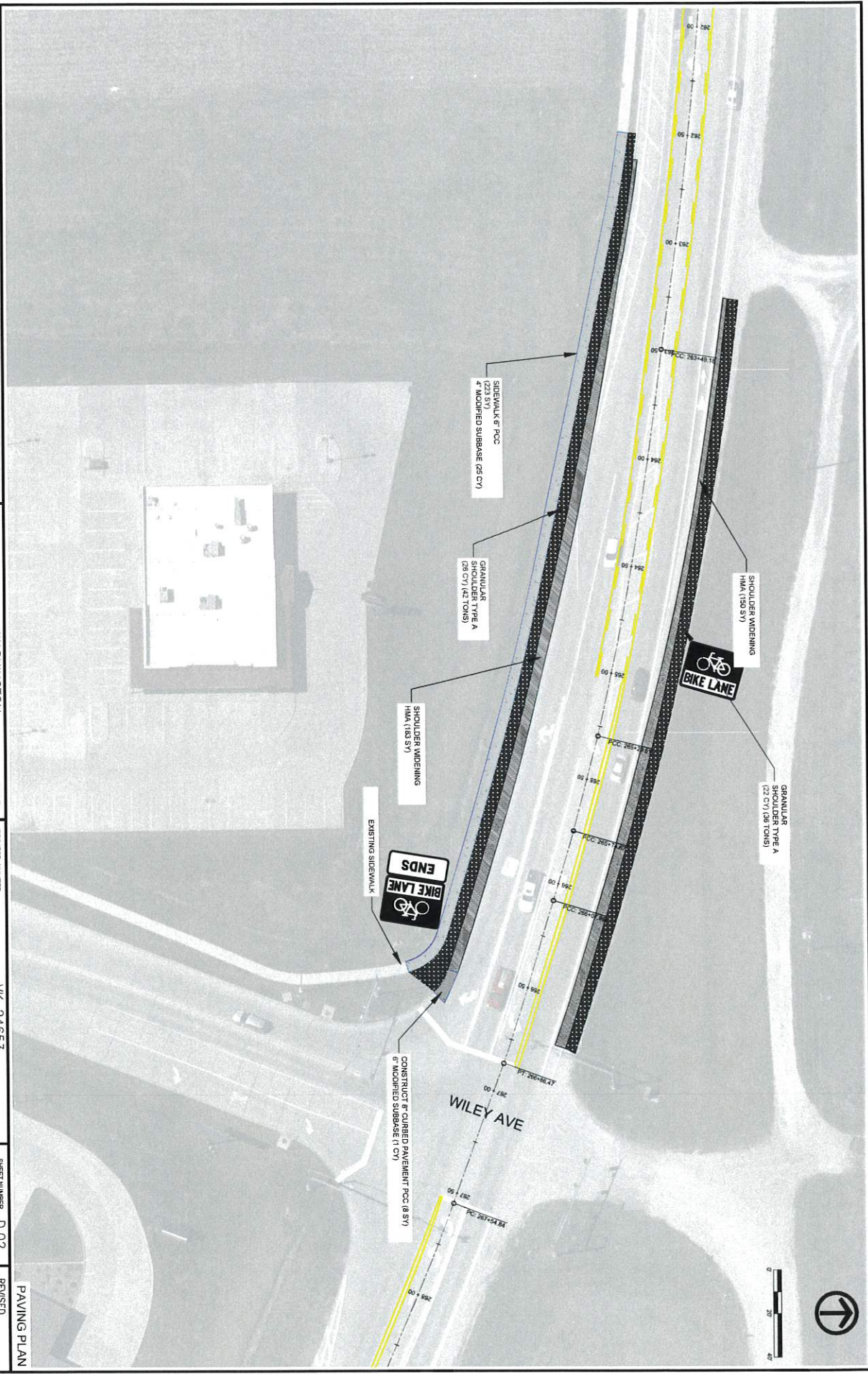



**General Phasing/Staging/Traffic Control Notes**

1. All traffic control devices required by the contract documents shall be furnished, erected, moved, maintained, and removed by the contractor.
2. The location for storage of equipment by the Contractor during non-working hours shall be as approved by the Engineer.
3. Proposed sign spacing may be modified as approved by the Engineer to meet existing field conditions.
4. Permanent signing that conveys a message contrary to the message of the temporary signing and not applicable to the working conditions shall be covered by Contractor with concurrence from Engineer.
5. The Contractor shall submit completed Traffic Control Diary entries to the Engineer weekly.
6. Per 23 CFR 634: "All workers within the Right-of-way of a federal-aid highway who are exposed either to traffic (vehicles using the highway for purposes of travel) or to construction equipment within the work area shall wear high-visibility safety apparel, which is defined to mean "personal protective safety clothing that is intended to provide conspicuity during both daytime and nighttime usage, and that meets the Performance Class 2 or 3 requirements of the ANSI/ISEA 107-2004".
7. Contractor shall notify the City, the Washington County Sheriff, the Iowa DOT District 5 maintenance office, and the Iowa DOT 511 system 10 days prior to any traffic control changes to Highway 1.

**Phasing Notes**

**Phase 1**

1. Striping - N side (4' width)

**Phase 2**

1. Striping - S side (4' width)

**Phase 3**

1. Intersection widening - Close 12th St
2. Shoulder Widening - East

**Phase 4**

1. Signal installation

**Phase 5**

1. Stop bars and crosswalks

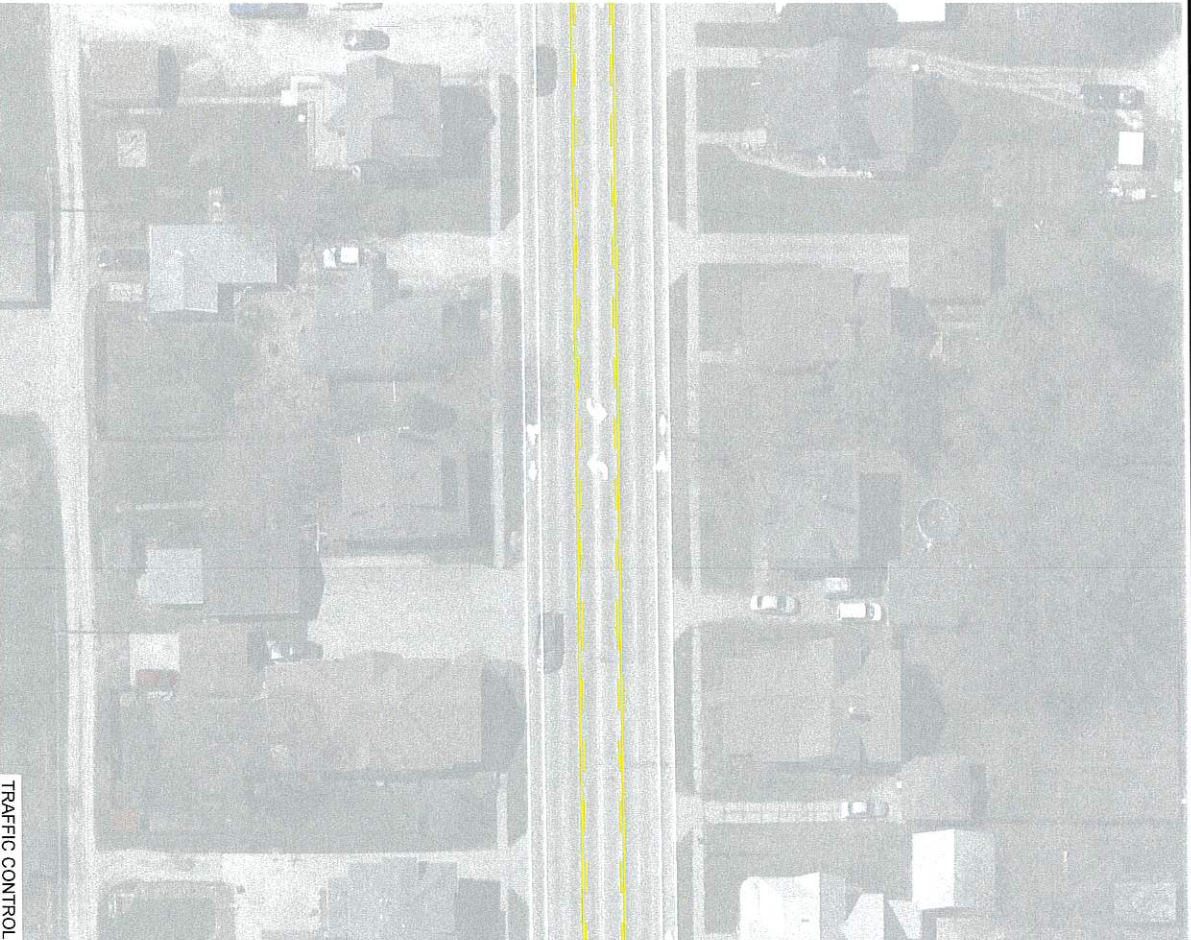

TRAFFIC CONTROL

ENGINEER: ENGLISH DESIGN TEAM  
 OWNER: OHM DOT  
 PROJECT NUMBER: WASHINGTON COUNTY  
 SHEET NUMBER: K.01  
 REVISION: REVISED

VEENSTRA & KIMM, INC.  
 WASHINGTON COUNTY  
 PROJECT NUMBER: VK 2465.3  
 SHEET NUMBER: K.01  
 REVISION: REVISED

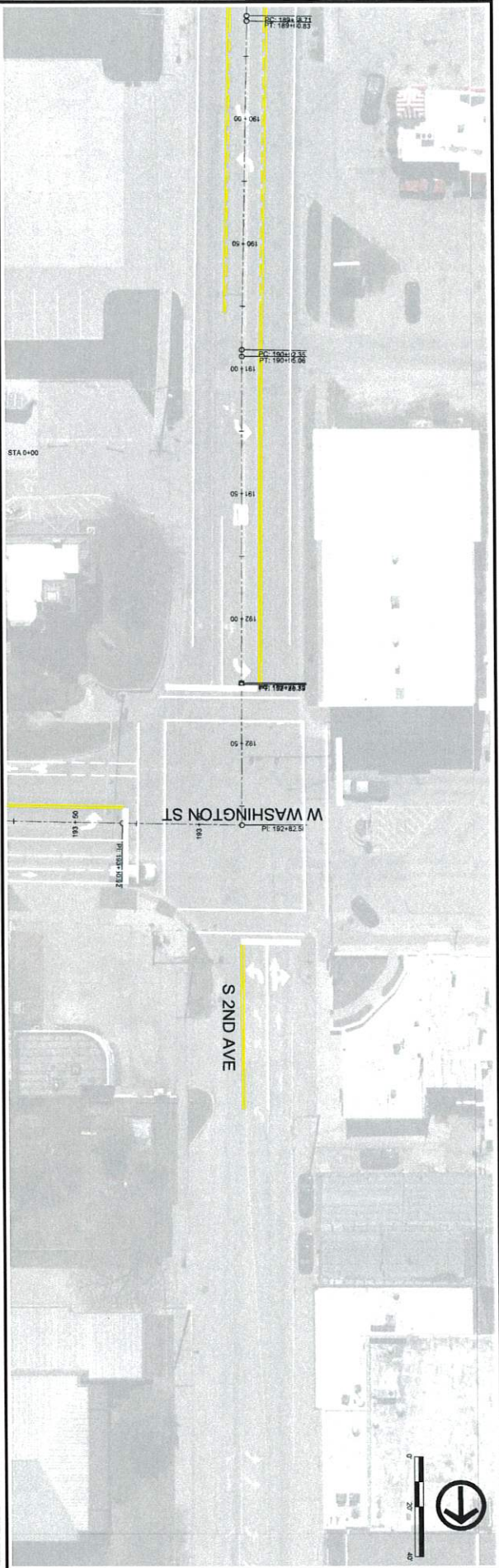
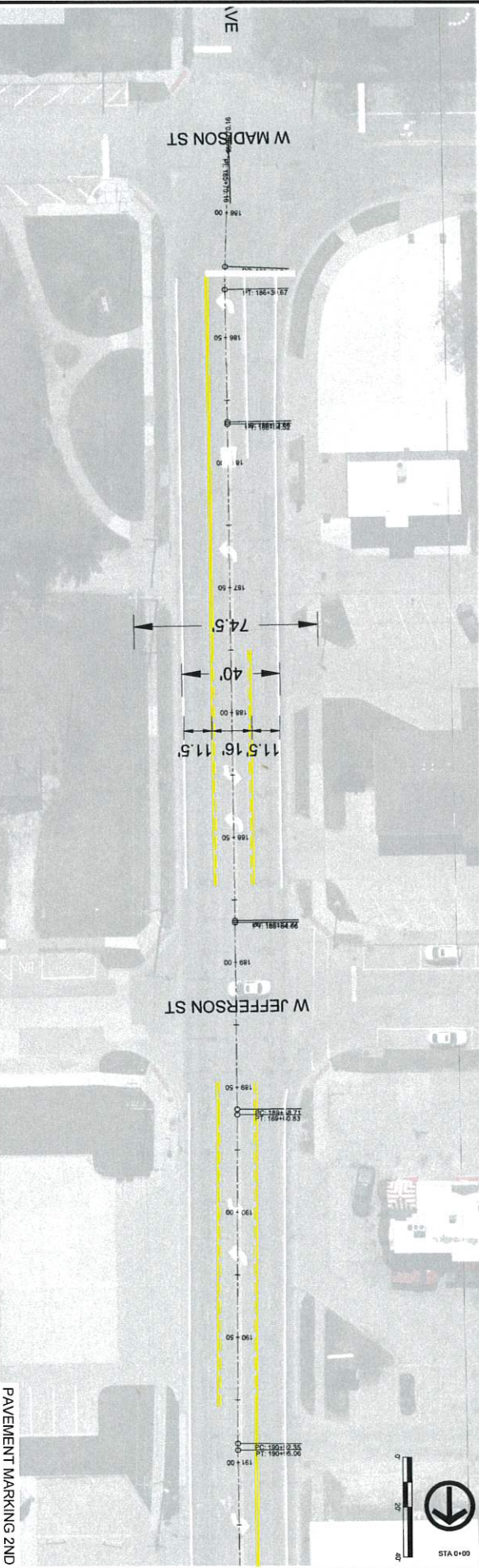

ENGLISH: 10/11/2017 10:00 AM  
 DESIGN TEAM: VEENSTRA & KIMM, INC.  
 WASHINGTON COUNTY PROJECT NUMBER: VK 24653  
 SHEET NUMBER: K-02  
 REVISIONS:

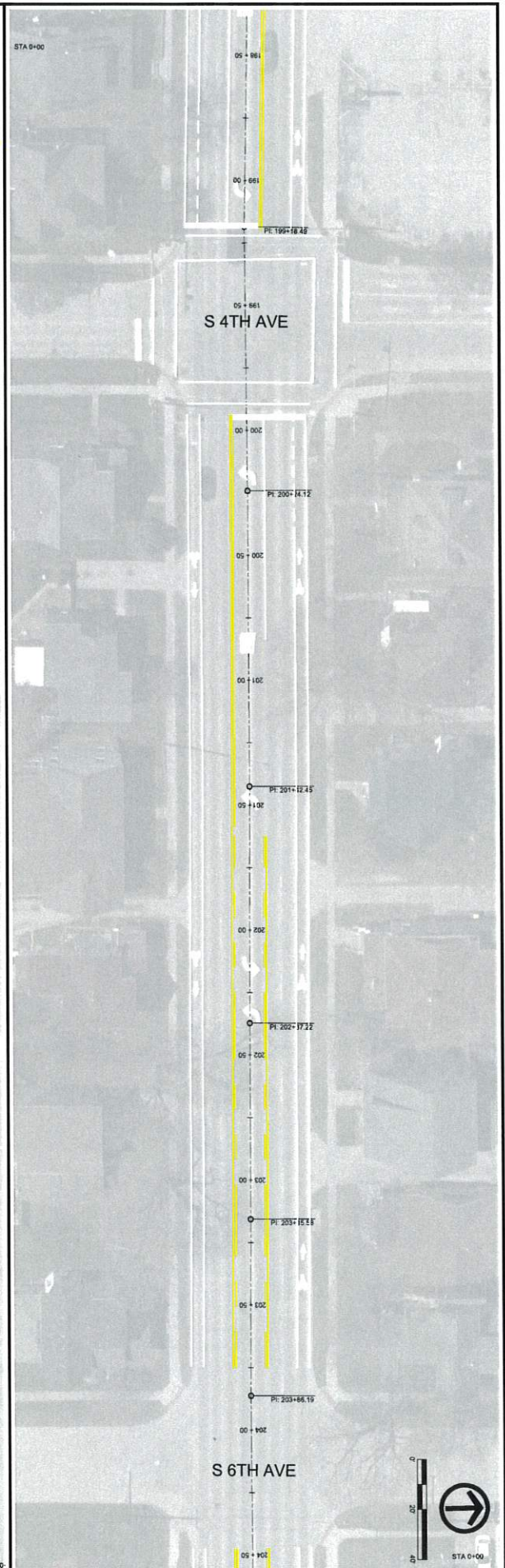
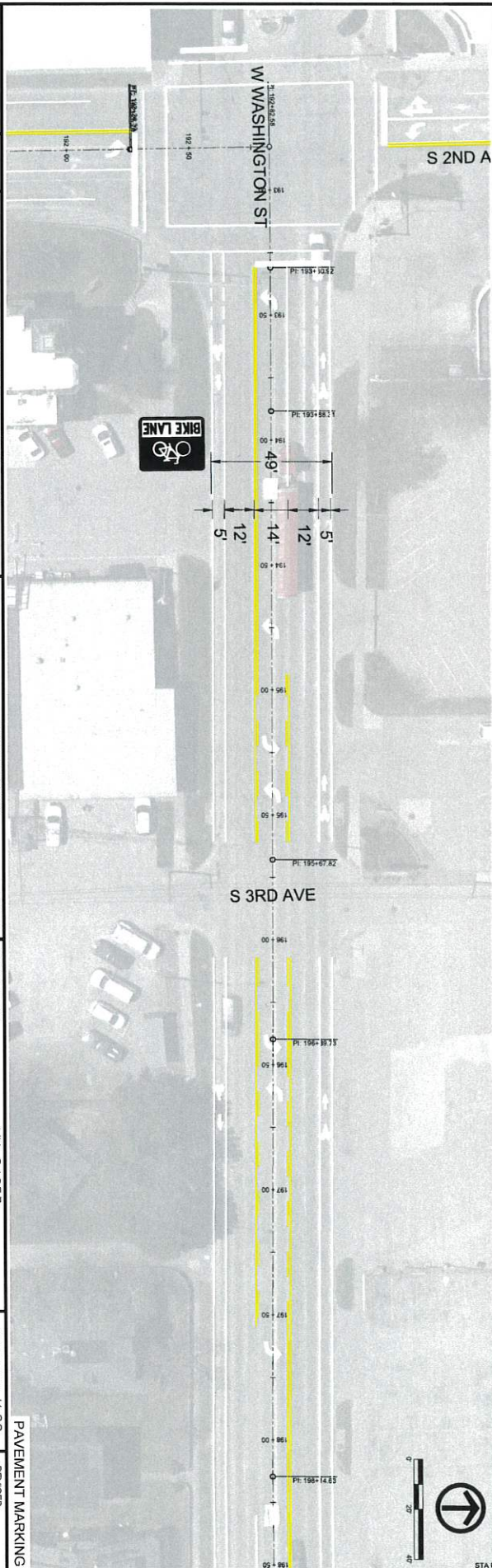

PAVEMENT MARKING

PROJECT: Intersecting Hwy 8, 2023, 3/23/21 PM  
ENGINEER: [Redacted]  
DATE: 03/23/21  
DESIGN TEAM: [Redacted]  
VENSTRA & KIMM, INC.  
WASHINGTON COUNTY PROJECT NUMBER: VK 2465.3  
SHEET NUMBER: K-03  
REVISED: [Redacted]

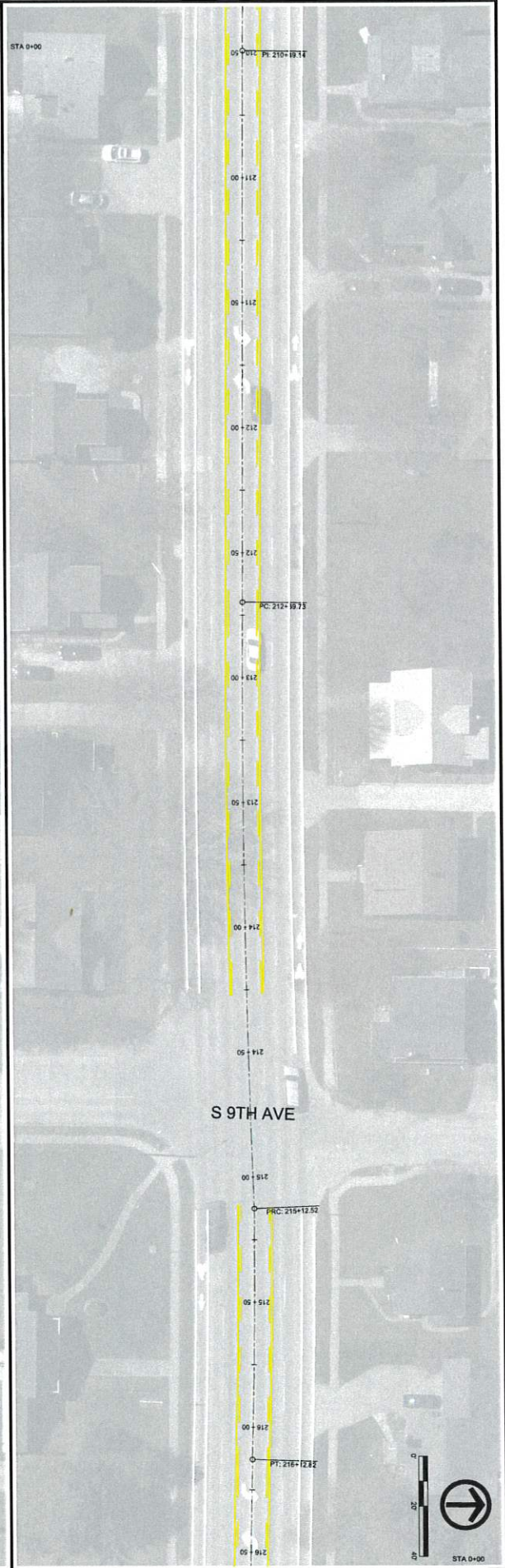
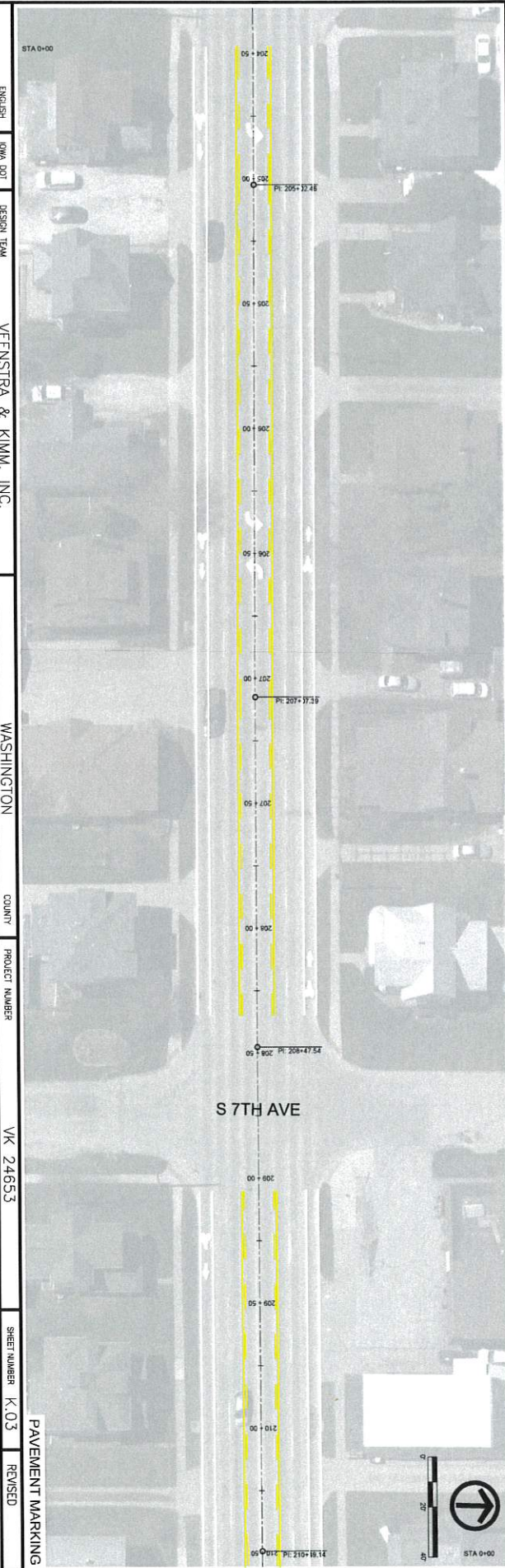

PROJECT NUMBER: VK 24653  
 SHEET NUMBER: K-04  
 REVISION: REVISED

ENGLISH: 08/11/2023 10:00 AM  
 DESIGN TEAM: VEENSTRA & KIMM, INC.  
 WASHINGTON COUNTY PROJECT NUMBER: VK 24653

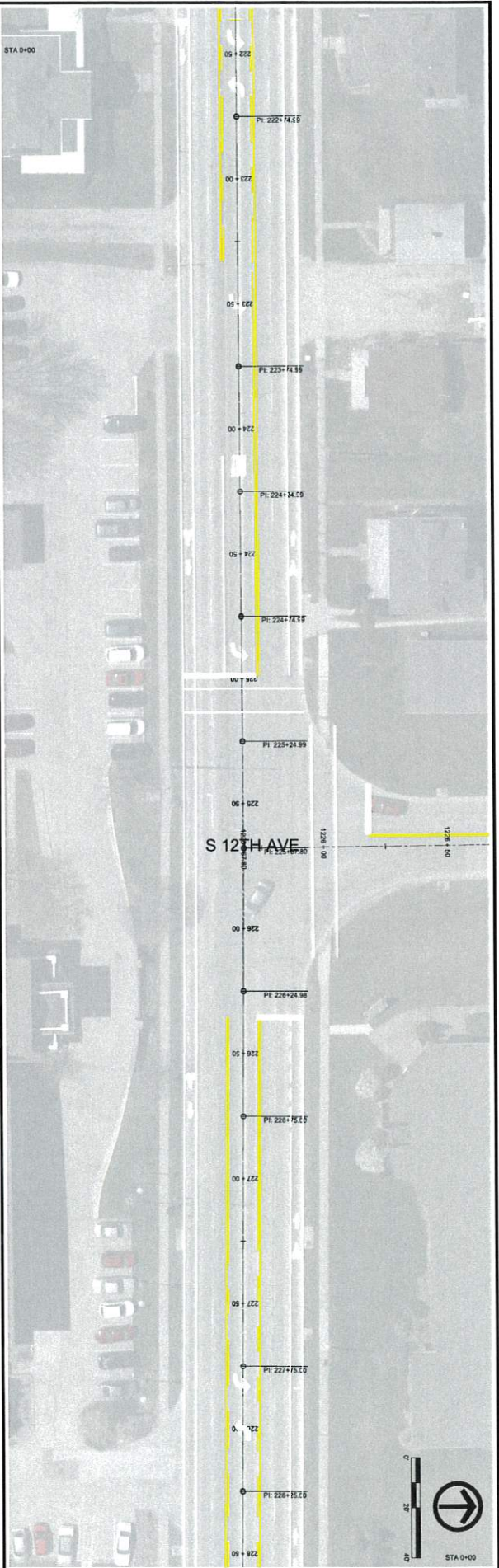
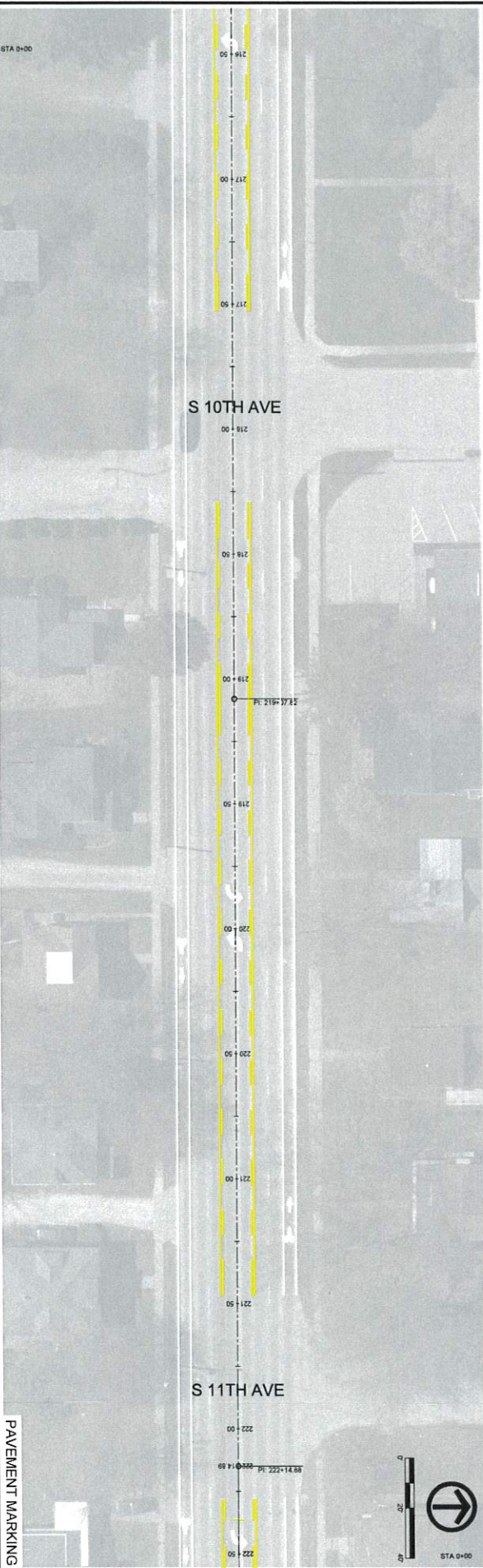

PAVEMENT MARKING

PROJECT: Intersect. Hwy 9, 2023-2025 PM  
ENGLISH: DWG: 101  
DESIGN TEAM: VEENSTRA & KIMM, INC.  
FILE PATH: Z:\WORKSPACE\24653\7211 & WASHINGTON INTERSECTION\PROJECT\DRAWINGS\PAVEMENT MARKING.dwg

WASHINGTON

COUNTY

PROJECT NUMBER

VK 24653

SHEET NUMBER K-05

REVISED

PAVEMENT MARKING

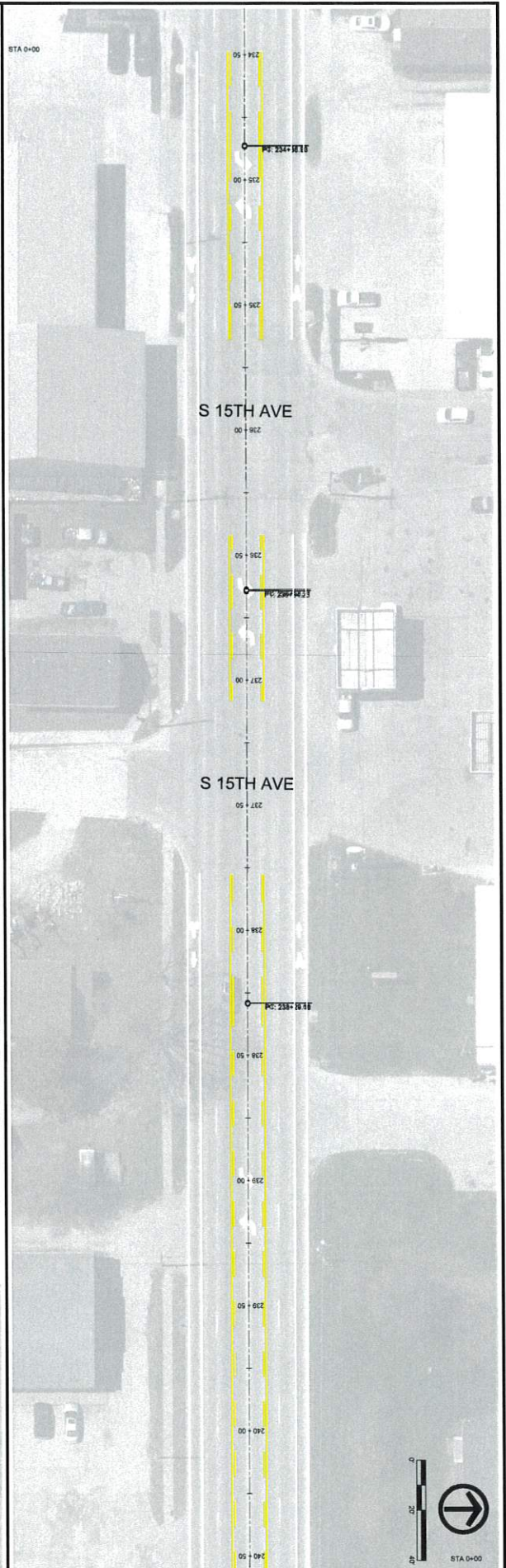
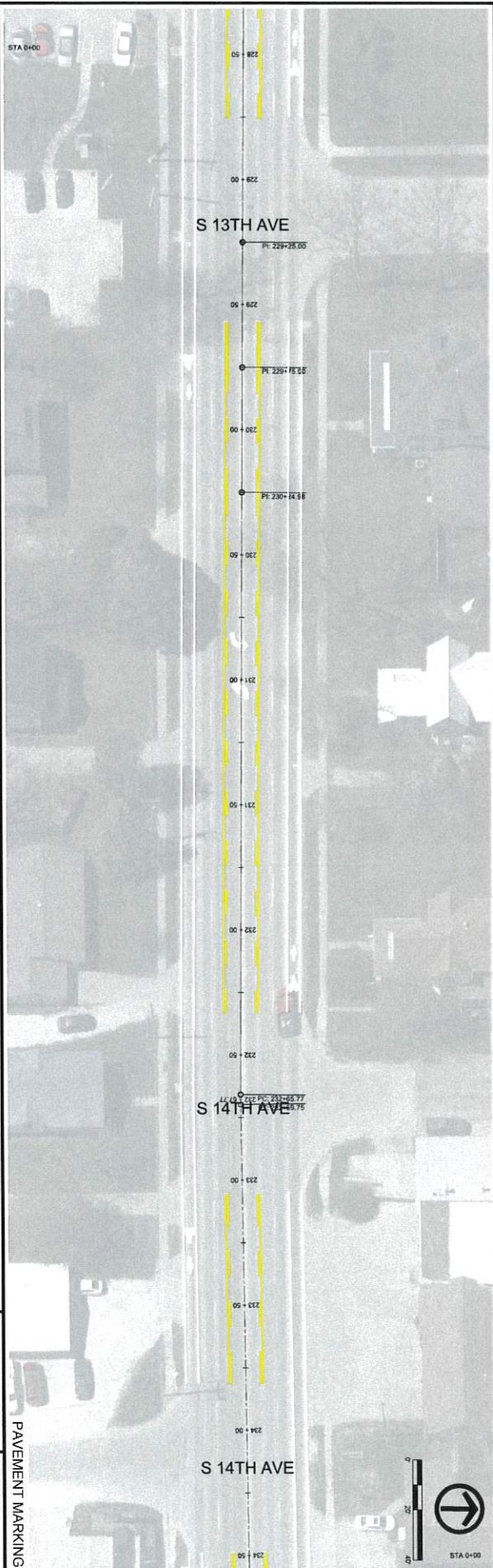



FILED: 1/14/20, 10:59 AM, 5, 2023, 13:33:11 PM

WASHINGTON

COUNTY

PROJECT NUMBER

VK 24653

SHEET NUMBER K.06

REVISED

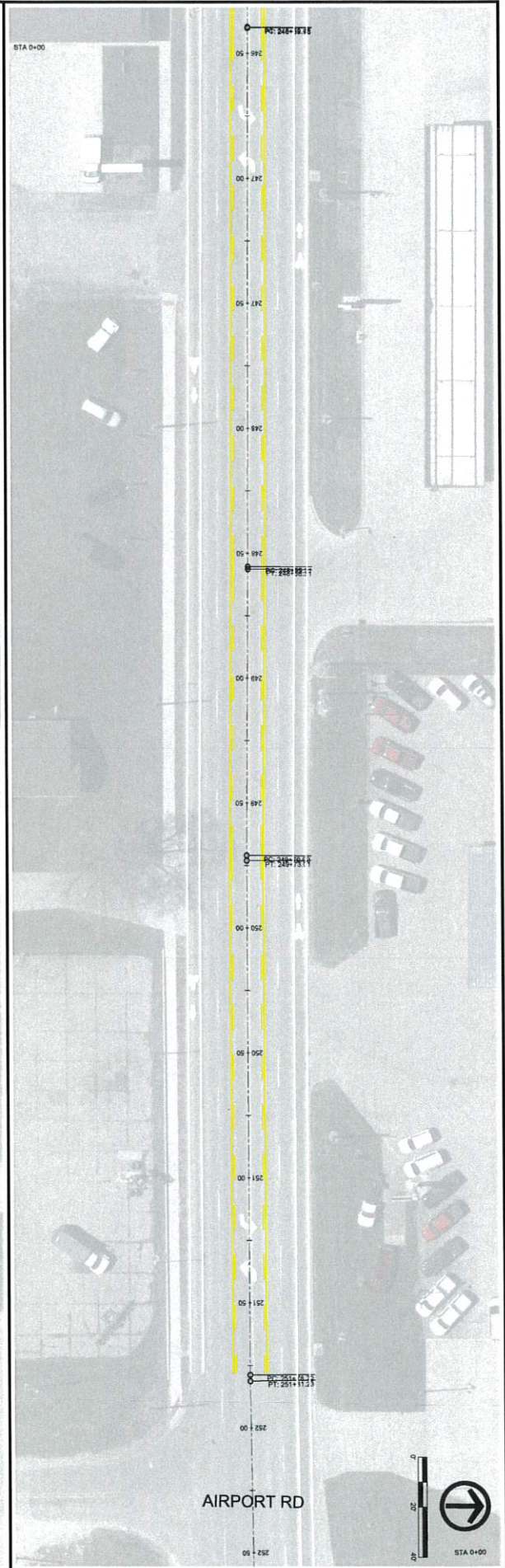
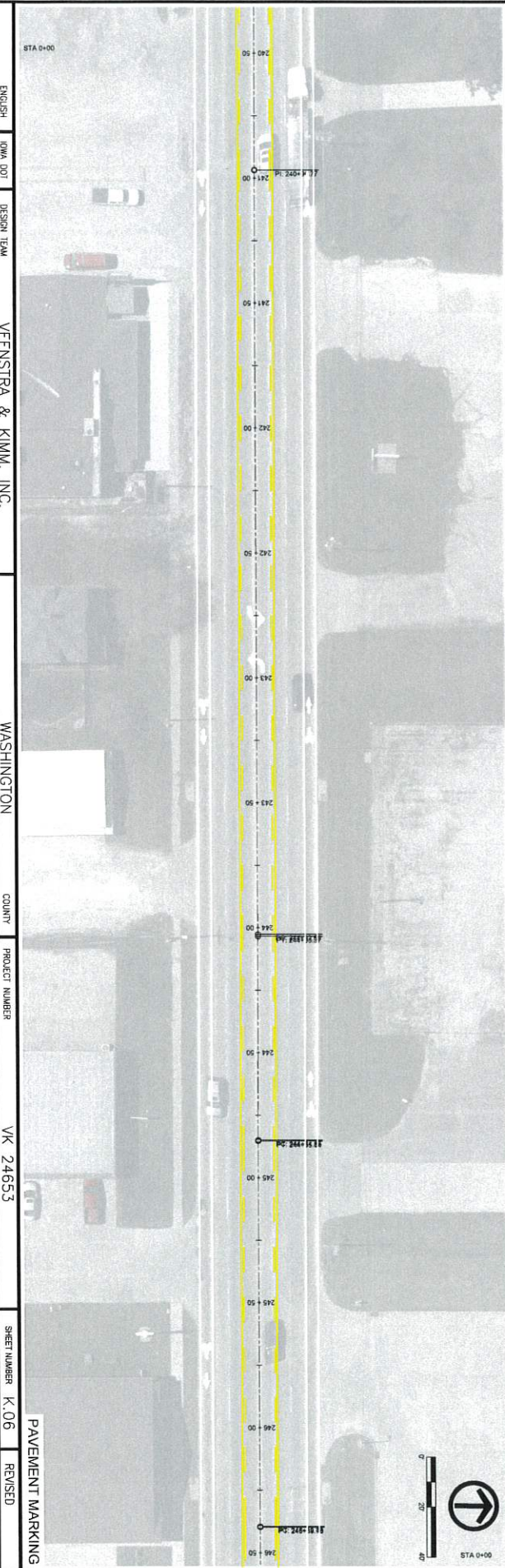

ENGLISH IOWA DOT DESIGN TEAM VEENSTRA & KIMM, INC. WASHINGTON COUNTY PROJECT NUMBER VK 24653 SHEET NUMBER K.07 REVISED

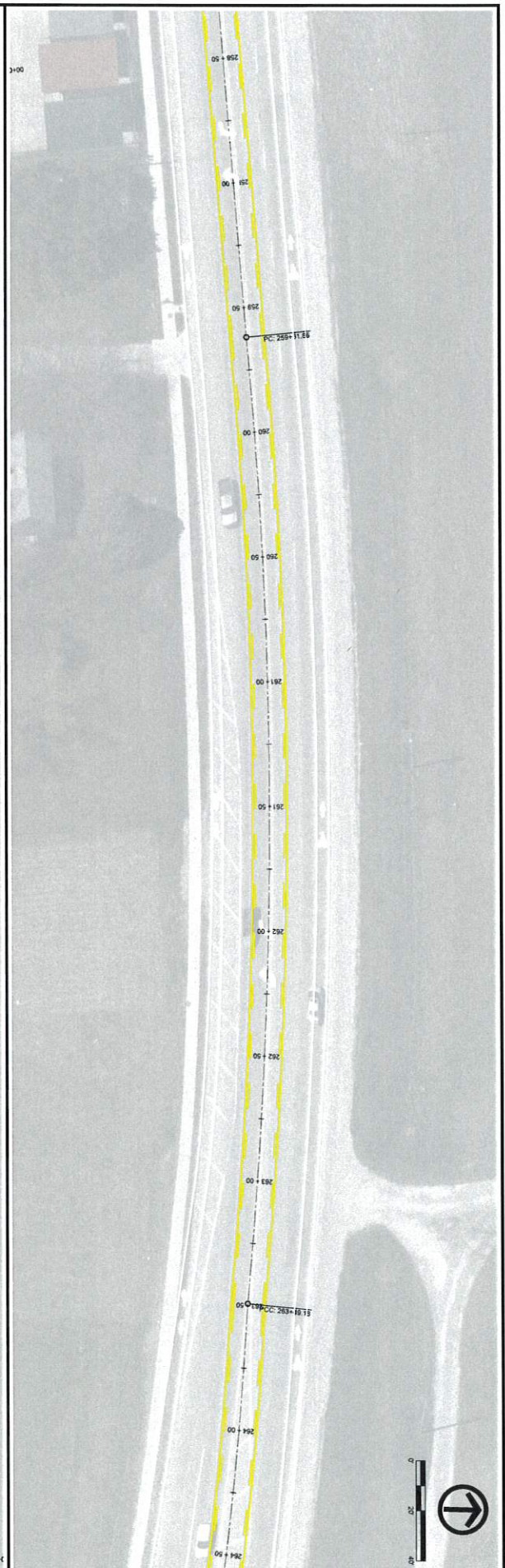
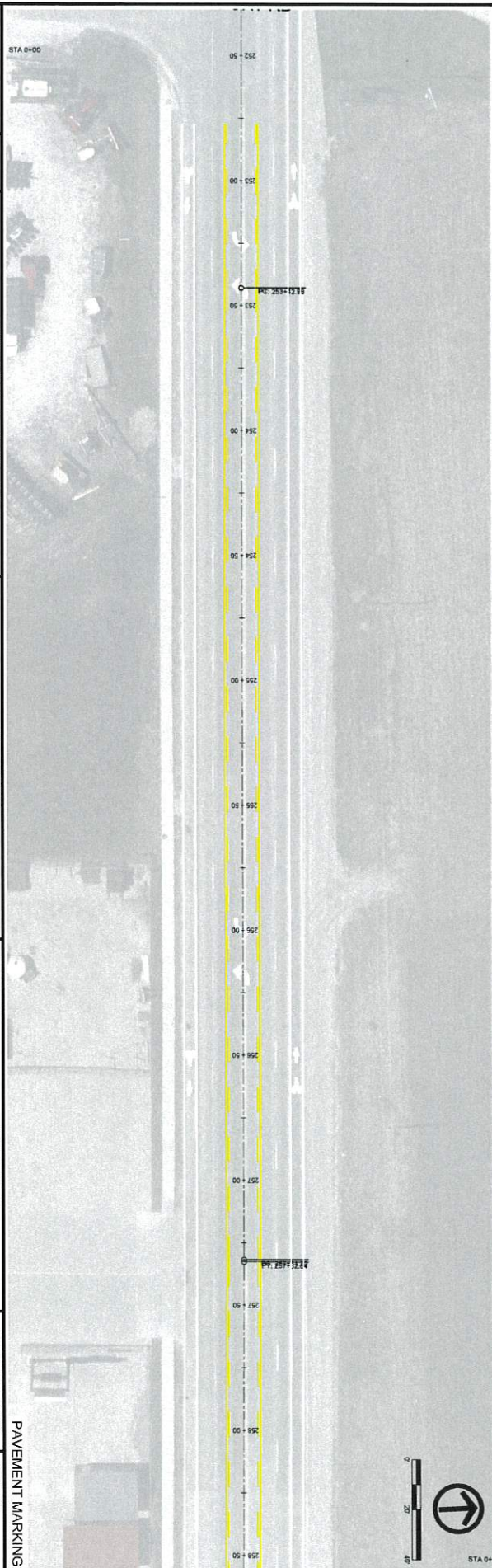

PAVEMENT MARKING

ENGLISH | OWNER: DOT | DESIGN TEAM: VEENSTRA & KIMM, INC. | COUNTY: WASHINGTON | PROJECT NUMBER: VK 24653 | SHEET NUMBER: K.08 | REVISION: PAVEMENT MARKING

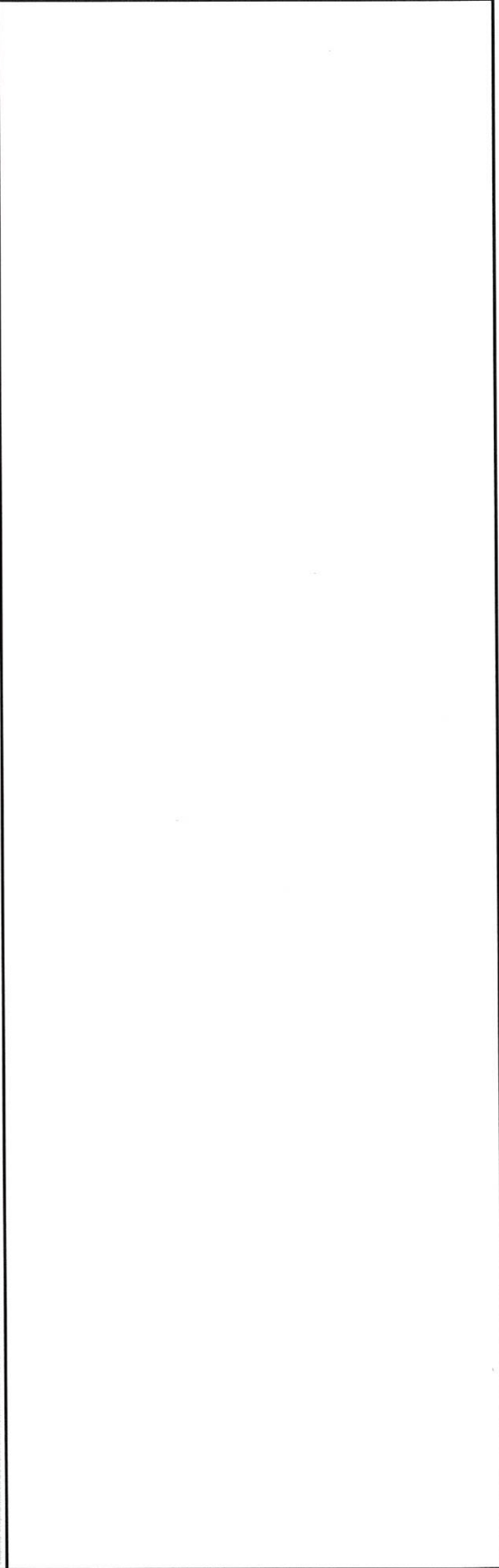
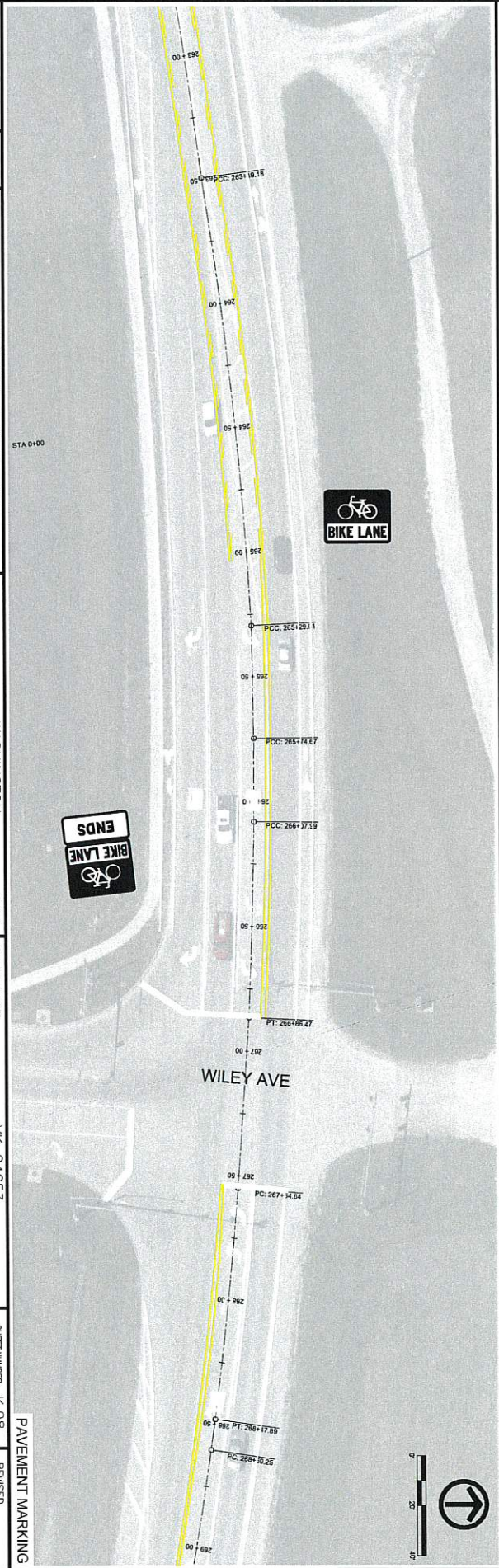

ENGLISH | 10/14/2007 | DESIGN TEAM | VEENSTRA & KIMM, INC. | WASHINGTON COUNTY | PROJECT NUMBER | VK 24653 | SHEET NUMBER | L.01 | REVISED

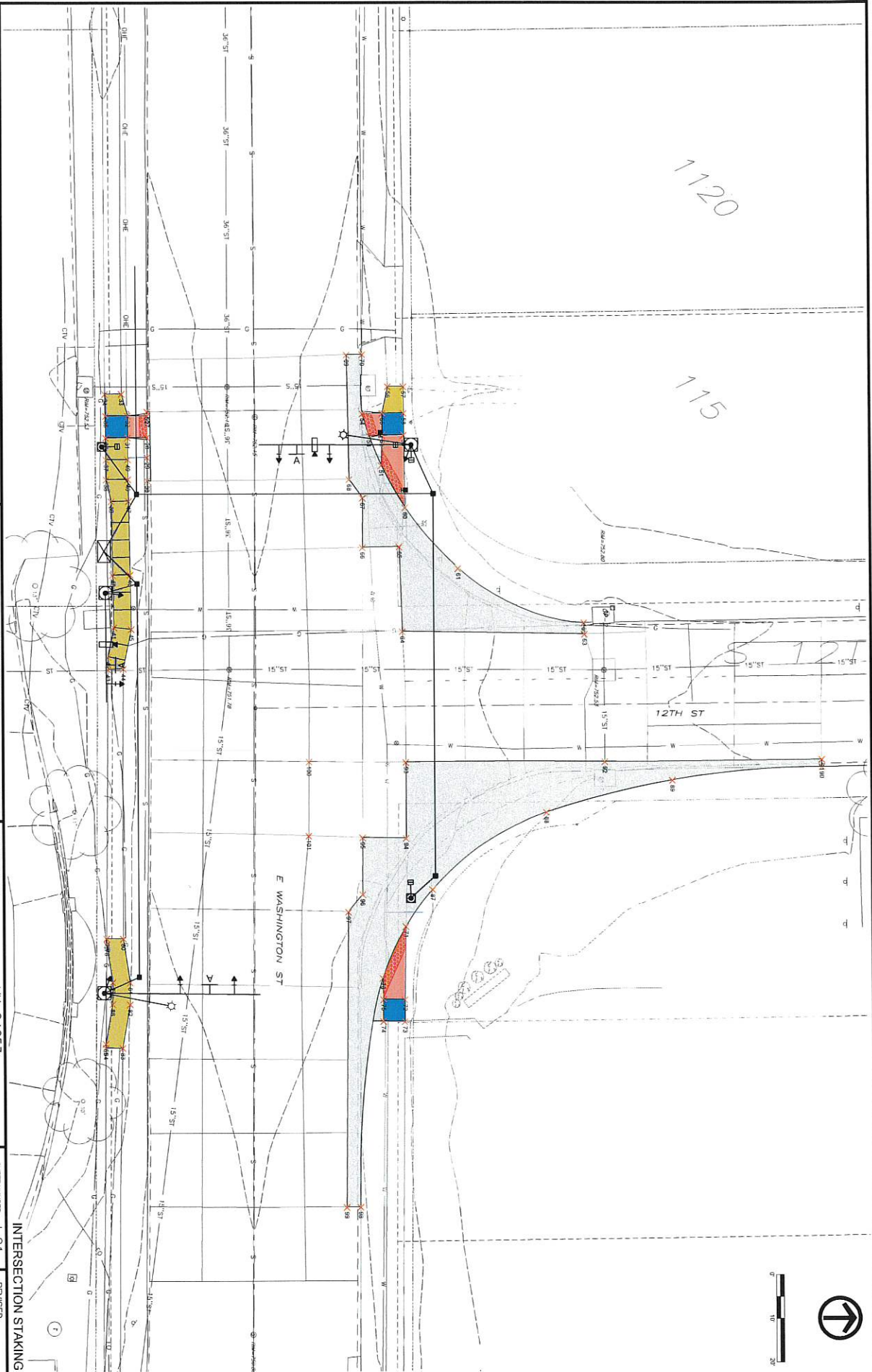

INTERSECTION STAKING

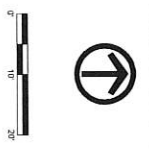

INTERSECTION STAKING

ENGINEER: [Name] DESIGN YEAR: [Year] DATE PLOTTED: 2/10/2010 10:52:33 AM

Point #	Point Description	Elevation	Stationing	Remarks
27		0.00	47206.6128	2140810.2588
28		0.00	47206.6100	2140812.2800
29		0.00	47206.6133	2140813.2481
30		0.00	47206.6188	2140813.7199
31		0.00	47206.6151	2140815.2722
32		0.00	47206.6199	2140816.3271
33		0.00	47206.6261	2140815.2881
34		0.00	47206.6179	2140815.3514
35		0.00	47206.6284	2140815.3678
36		0.00	47206.6284	2140815.3680
37		0.00	47206.6284	2140815.3681
38		0.00	47206.6284	2140815.3682
39		0.00	47206.6284	2140815.3683
40		0.00	47206.6284	2140815.3684
41		0.00	47206.6284	2140815.3685
42		0.00	47206.6284	2140815.3686
43		0.00	47206.6284	2140815.3687
44		0.00	47206.6284	2140815.3688
45		0.00	47206.6284	2140815.3689
46		0.00	47206.6284	2140815.3690
47		0.00	47206.6284	2140815.3691
48		0.00	47206.6284	2140815.3692
49		0.00	47206.6284	2140815.3693
50		0.00	47206.6284	2140815.3694
51		0.00	47206.6284	2140815.3695
52		0.00	47206.6284	2140815.3696
53		0.00	47206.6284	2140815.3697
54		0.00	47206.6284	2140815.3698
55		0.00	47206.6284	2140815.3699
56		0.00	47206.6284	2140815.3700
57		0.00	47206.6284	2140815.3701
58		0.00	47206.6284	2140815.3702
59		0.00	47206.6284	2140815.3703
60		0.00	47206.6284	2140815.3704
61		0.00	47206.6284	2140815.3705
62		0.00	47206.6284	2140815.3706
63		0.00	47206.6284	2140815.3707
64		0.00	47206.6284	2140815.3708
65		0.00	47206.6284	2140815.3709
66		0.00	47206.6284	2140815.3710
67		0.00	47206.6284	2140815.3711
68		0.00	47206.6284	2140815.3712
69		0.00	47206.6284	2140815.3713
70		0.00	47206.6284	2140815.3714
71		0.00	47206.6284	2140815.3715
72		0.00	47206.6284	2140815.3716
73		0.00	47206.6284	2140815.3717
74		0.00	47206.6284	2140815.3718
75		0.00	47206.6284	2140815.3719
76		0.00	47206.6284	2140815.3720

Point #	Point Description	Elevation	Stationing	Remarks
77		0.00	47206.6284	2140815.3721
78		0.00	47206.6284	2140815.3722
79		0.00	47206.6284	2140815.3723
80		0.00	47206.6284	2140815.3724
81		0.00	47206.6284	2140815.3725
82		0.00	47206.6284	2140815.3726
83		0.00	47206.6284	2140815.3727
84		0.00	47206.6284	2140815.3728
85		0.00	47206.6284	2140815.3729
86		0.00	47206.6284	2140815.3730
87		0.00	47206.6284	2140815.3731
88		0.00	47206.6284	2140815.3732
89		0.00	47206.6284	2140815.3733
90		0.00	47206.6284	2140815.3734
91		0.00	47206.6284	2140815.3735
92		0.00	47206.6284	2140815.3736
93		0.00	47206.6284	2140815.3737
94		0.00	47206.6284	2140815.3738
95		0.00	47206.6284	2140815.3739
96		0.00	47206.6284	2140815.3740
97		0.00	47206.6284	2140815.3741
98		0.00	47206.6284	2140815.3742
99		0.00	47206.6284	2140815.3743
100		0.00	47206.6284	2140815.3744
101		0.00	47206.6284	2140815.3745

SIGNAL NOTES	
<p><b>GENERAL</b></p> <ol style="list-style-type: none"> <li>CONTRACTOR IS RESPONSIBLE FOR CONTACTING ONE-CALL PRIOR TO BEGINNING CONSTRUCTION.</li> <li>CONTRACTOR SHALL NOTIFY THE CITY 48-72 HOURS PRIOR TO BEGINNING CONSTRUCTION WITHIN THE PUBLIC RIGHT-OF-WAY.</li> <li>ALL WORK, INCLUDING EQUIPMENT, MATERIALS AND INSTALLATION SHALL BE IN ACCORDANCE WITH IOWA DOT STANDARD SPECIFICATIONS FOR HIGHWAY AND BRIDGE CONSTRUCTION UNLESS OTHERWISE NOTED. TRAFFIC CONTROL DEVICES FOR STREETS AND HIGHWAYS.</li> <li>ALL QUANTITIES SHOWN IN THE PLANS AND SPECIFICATIONS ARE FOR INFORMATIONAL AND ESTIMATING PURPOSES ONLY. THE CONTRACTOR SHALL VERIFY ALL QUANTITIES AND MATERIALS BEFORE BEGINNING WORK. LABOR, TOOLS, EQUIPMENT AND MATERIALS NECESSARY TO PROVIDE A COMPLETE AND FUNCTIONAL TRAFFIC SIGNAL INSTALLATION IN COMPLIANCE WITH THE PLANS AND SPECIFICATIONS.</li> <li>ALL WORK SHALL BE DONE IN ACCORDANCE WITH THE SPECIFICATIONS OF THE IOWA DOT. ALL MATERIALS SHALL BE APPROVED BY THE ENGINEER. MATERIALS SHALL BE STORED IN A DRY AND PROTECTED AREA. ALL MATERIALS SHALL BE PROTECTED FROM WEATHER AND SHALL BE KEPT IN A DRY AND PROTECTED AREA. ALL MATERIALS SHALL BE KEPT IN A DRY AND PROTECTED AREA. ALL MATERIALS SHALL BE KEPT IN A DRY AND PROTECTED AREA.</li> <li>IT SHALL BE THE CONTRACTOR'S RESPONSIBILITY TO PROVIDE WRITE-UP OF ALL WORK. ALL WORK SHALL BE DONE IN ACCORDANCE WITH THE SPECIFICATIONS OF THE IOWA DOT. ALL MATERIALS SHALL BE APPROVED BY THE ENGINEER. MATERIALS SHALL BE STORED IN A DRY AND PROTECTED AREA. ALL MATERIALS SHALL BE PROTECTED FROM WEATHER AND SHALL BE KEPT IN A DRY AND PROTECTED AREA. ALL MATERIALS SHALL BE KEPT IN A DRY AND PROTECTED AREA.</li> <li>THE TOP SIX (6) INCHES OF THE ASPHALTED AREAS SHALL BE FREE OF ROCK AND DEBRIS AND SHALL BE SUITABLE FOR THE ESTABLISHMENT OF VEGETATION, SUBJECT TO THE APPROVAL OF THE ENGINEER.</li> <li>THE LOCATION OF UTILITY MAINS, STRUCTURES AND SERVICE CONNECTIONS IS NOTED ON THE DRAWING AND APPROVED ONLY. ALL UTILITY MAINS, STRUCTURES AND SERVICE CONNECTIONS NOT SHOWN ON THE DRAWING, THE EXISTING UTILITY MAINS, STRUCTURES AND SERVICE CONNECTIONS OF THE EXACT LOCATION OF UTILITY MAINS, STRUCTURES AND SERVICE CONNECTIONS SHALL BE THE RESPONSIBILITY OF THE CONTRACTOR.</li> <li>THE MEANS OF THE WORK AND THE SAFETY OF THE CONTRACTOR'S EMPLOYEES ARE SOLELY THE RESPONSIBILITY OF THE CONTRACTOR.</li> <li>SITE CLEANUP SHALL BE PERFORMED ON A DAILY BASIS. SIGNMASS, PARKING LOTS, ROADWAYS, ETC. SHALL BE KEPT CLEAN AT ALL TIMES.</li> <li>CONSTRUCTION ACTIVITIES ARE TO BE LIMITED TO THE EXISTING RIGHT-OF-WAY AND TEMPORARY CONSTRUCTION EASEMENTS. IF ADDITIONAL AREAS ARE NEEDED FOR STAGING, STORAGE, ETC. IT IS THE CONTRACTOR'S RESPONSIBILITY TO OBTAIN WRITTEN PERMISSION FROM THE PROPERTY OWNERS. COPIES OF THE AGREEMENTS SHALL BE SUBMITTED TO THE OWNER'S REPRESENTATIVE PRIOR TO THE USE OF PROPERTY.</li> </ol> <p><b>STANDARD</b></p> <ol style="list-style-type: none"> <li>CONTRACTOR SHALL SUBMIT A SCHEDULE OF UNIT PRICES.</li> <li>CONTRACTOR SHALL SUBMIT A MATERIAL AND EQUIPMENT LIST.</li> <li>CONTRACTOR SHALL SUBMIT COPIES OF IOWA CERTIFICATIONS FOR TECHNICIAN WORKING ON PROJECT.</li> <li>CONTRACTOR SHALL SUBMIT SHOP DRAWINGS FOR TRAFFIC SIGNAL POLES AND STRUCTURES TO BE FURNISHED ON THE PROJECT. SUBMIT DETAILS CUTS AND MANUFACTURER'S SPECIFICATIONS FOR ALL ITEMS IN THE EQUIPMENT LIST.</li> <li>FILE DOCUMENTATION PACKAGES SHALL BE PROVIDED WITH EACH SIGNAL SYSTEM WHICH SHALL CONSIST OF THE FOLLOWING:             <ol style="list-style-type: none"> <li>COMPLETE CABINET WIRING DIAGRAM</li> <li>COMPLETE PHYSICAL DESCRIPTION OF EQUIPMENT</li> <li>CONTROLLER'S PRINTOUT OR EQUAL DOCUMENTATION OF INITIAL CONTROLLER SETTINGS INSTALLED IN THE FIELD OR IN THE OFFICE</li> <li>PRODUCT MANUALS FOR ALL CABINET EQUIPMENT</li> <li>STANDARD INDUSTRY WARRANTIES ON EQUIPMENT SUPPLIER</li> <li>DOCUMENTATION OF FIELD CABLE LABELING SCHEME</li> <li>DIAGRAM OF PHASING AND DETECTOR LOCATIONS</li> <li>ONE SET OF AS-BUILT PLANS INDICATING CHANGES FROM THE ORIGINAL CONTRACT DOCUMENTS</li> <li>SUPPLY TWO COMPLETE SETS OF DOCUMENTATION, ONE SET IN THE CONTROLLER CABINET AND THE OTHER DELIVERED TO THE ENGINEER.</li> </ol> </li> </ol>	<p><b>TESTING</b></p> <ol style="list-style-type: none"> <li>MATERIAL TESTING SHALL BE IN ACCORDANCE WITH IOWA DOT SPECIFICATIONS AND INSTRUCTIONAL MEMORANDUM (IMV).</li> <li>CONTRACTOR TO COORDINATE WITH OWNER'S MATERIAL TESTING COMPANY FOR AIR &amp; SLUMP TESTS ON STRUCTURAL CONCRETE</li> <li>CONTRACTOR SHALL SUBMIT IOWA DOT MATERIAL CERTIFICATIONS INCLUDING ANCHOR BOLTS, HANCHOLETS, CONDUIT, WIRING AND DETECTOR LAYOUTS.</li> <li>CONTRACTOR SHALL TEST DETECTION AND DOCUMENT THE RESULTS.</li> <li>THE CONTRACTOR SHALL NOTIFY THE ENGINEER 48 HRS IN ADVANCE OF THE TIME AND DATE THE SIGNAL WILL BE READY FOR TURN ON. DO NOT TURN ON UNTIL AUTHORIZED BY ENGINEER.</li> <li>RESERVE A REPRESENTATIVE FROM THE MANUFACTURER AND/OR SUPPLIER OF SIGNAL CONTROLLER OR TURNED ON TO PROVIDE TECHNICAL ASSISTANCE INCLUDING, AS A MINIMUM, PROGRAMMING OF ALL NECESSARY INPUT DATA.</li> <li>A TEST PERIOD OF 30 CALENDAR DAYS WILL START UPON COMPLETION FROM THE ENGINEER THAT THE SIGNAL OR SIGNAL SYSTEM IS OPERATING CONSISTENT WITH THE PRODUCT REQUIREMENTS. ANY FAILURE OR MALFUNCTION OF THE EQUIPMENT FURNISHED BY THE CONTRACTOR OCCURRING DURING THE TEST PERIOD WILL BE COVERED BY THE CONTRACTOR AT NO ADDITIONAL COST TO THE COUNTY. THE CONTRACTOR SHALL BE RESPONSIBLE FOR THE COSTS OF THE TEST PERIOD. A MINIMUM TEST PERIOD OF 30 CALENDAR DAYS WILL START EXCLUDING OF MINOR MALFUNCTIONS SUCH AS LAMP BURNOUTS. REPORT THIS PROCEDURE UNTIL THE SIGNAL EQUIPMENT HAS OPERATED SATISFACTORILY FOR 30 CONSECUTIVE CALENDAR DAYS.</li> <li>AFTER SIGNAL TURN ON AND PRIOR TO COMPLETION OF THE 30 CALENDAR DAY TEST PERIOD, RESPONSE WITHIN 24 HOURS, TO PERFORM MAINTENANCE OR REPAIR OF ANY FAILURE OR MALFUNCTION REPORTED.</li> </ol> <p><b>ELECTRICAL SERVICE</b></p> <ol style="list-style-type: none"> <li>CONTRACTOR SHALL COORDINATE DIRECTLY WITH THE UTILITY COMPANY FOR INSTALLATION OF THE ELECTRICAL SERVICE.</li> <li>CONTRACTOR SHALL FURNISH AND INSTALL SERVICE PANEL, METER SOCKET, CONDUIT, AND WIRES TO EXISTING POWER POLE. CONTRACTOR IS RESPONSIBLE FOR CONTACTING THE UTILITY COMPANY FOR EXACT SERVICE REQUIREMENTS.</li> </ol> <p><b>WIRING, CONDUIT AND ENCLOSURES</b></p> <ol style="list-style-type: none"> <li>ALL SIGNAL CABLE SHALL BE CONTINUOUS FROM CONNECTIONS MADE IN THE HANCHOLE COMPARTMENTS OF SIGNAL POLE BASES TO THE TERMINAL COMPARTMENT OF THE CONTROLLER CABINET AND THE SIGNAL HEADS.</li> <li>ALL POLES AND CONTROLLER CABINET SHALL BE INDEPENDENTLY GROUNDING AS SHOWN IN THE DETAILS AND AS DESCRIBED IN THE IOWA DOT STANDARD SPECIFICATION FOR TRAFFIC SIGNALIZATION.</li> <li>ALL CONDUIT UNDER PAVED AREAS SHALL BE FINISHED, SCHEDULE 40 PVC CONDUIT 3/4" DIAMETER UNLESS OTHERWISE NOTED. CONDUIT UNDER UNPAVED AREAS MAY BE SCHEDULE 40 PVC.</li> <li>ALL VIDEO DETECTION WIRING SHALL BE CONTINUOUS FROM THE CAMERA TO THE CONTROLLER.</li> </ol> <p><b>TRAFFIC SIGNALS</b></p> <ol style="list-style-type: none"> <li>SIGNAL HEAD ALIGNMENT SHALL BE DIRECTED TOWARD THE LANE OF TRAVEL.</li> <li>ALL WASTEBAIL MOUNTED VEHICLE SIGNAL HEADS SHALL COME FURNISHED WITH BACK-PLATES AND BE CENTERED OVER THEIR RESPECTIVE LANES.</li> <li>THE STATION RESPONSIBLE FOR THE SIGNAL PLANS ARE TO BE THE CENTER OF THE HEAD UNLESS OTHERWISE NOTED. THE CONTRACTOR SHALL FIELD VERIFY ALL EQUIPMENT LOCATIONS WITH THE CITY AND THE PROJECT ENGINEER.</li> <li>HANCHOLETS SHALL NOT BE PLACED IN DITCH BOTTOMS.</li> <li>TRAFFIC SIGNAL POLES AND MAST ARMS SHALL BE POWDER COATED COLORED BLACK RAL 9011.</li> <li>ALL TRAFFIC AND PRESENCE COUNTDOWN INDICATIONS SHALL BE LED.</li> </ol> <p><b>TRAFFIC CONTROL</b></p> <ol style="list-style-type: none"> <li>THROUGH TRAFFIC SHALL BE MAINTAINED WHILE WORK IS IN PROGRESS ON THE PROJECT AND TRAFFIC CONTROL SHALL BE IN ACCORDANCE WITH IOWA DOT STANDARD ROAD PLANS.             <ul style="list-style-type: none"> <li>TO-22 TRAFFIC CONTROL LAYOUT FOR WORK WITHIN 18 FT OF TRAVELLED WAY</li> <li>TO-212 TRAFFIC CONTROL LAYOUT FOR SPOT LOCATION LANE CLOSURE WITH FLAGGER</li> <li>TO-213 TRAFFIC CONTROL LAYOUT FOR LANE CLOSURE WITH FLAGGER</li> </ul> </li> <li>ALL TRAFFIC CONTROL DEVICES UTILIZED SHALL BE IN ACCORDANCE WITH THE MANUAL ON UNIFORM TRAFFIC CONTROL DEVICES (MUTCD).</li> <li>THE CONTRACTOR SHALL PROVIDE PROPERLY EQUIPPED FLAG PERSONS AND ALL ASSOCIATED TRAFFIC CONTROL DEVICES WHENEVER IT IS NECESSARY TO DISRUPT THE FLOW OF TRAFFIC.</li> <li>THE ENGINEER MAY RESTRICT CERTAIN SIGNAL WORK TO SPECIFIC PERIODS OF TIME IF NECESSARY TO MAINTAIN ACCEPTABLE TRAFFIC FLOW.</li> <li>ALL TRAFFIC CONTROL DEVICES SHALL BE FURNISHED, ERECTED, MAINTAINED, AND REMOVED BY THE CONTRACTOR.</li> <li>ALL MAINTENANCE FOR TRAFFIC CONTROL DEVICES SHALL OCCUR DURING NON-WORKING HOURS IN ORDER TO BE ASSURED OF PROPER OPERATION. COSTS OF MAINTENANCE WILL BE INCLUDED IN THE TRAFFIC CONTROL BID ITEM.</li> <li>SAFETY FENCE, WHEN USED FOR TRAFFIC CONTROL OR PROTECTION OF THE WORK SITE, MUST BE FULLY SUPPORTED IN A VERTICAL POSITION. TENSION SUPPORT WIRES AND END ANCHORAGES WILL BE REQUIRED FOR SUPPORT. COSTS OF THESE ITEMS WILL BE INCLUDED IN THE TRAFFIC CONTROL BID ITEM.</li> <li>WHERE POSSIBLE, ALL POST MOUNTED SIGNS SHALL BE PLACED A MINIMUM OF 2 FEET CLEAR OF THE SHOULDER.</li> <li>THE LOCATION FOR STORAGE OF EQUIPMENT BY THE CONTRACTOR DURING NON-WORKING HOURS SHALL BE APPROVED BY THE ENGINEER. ALL EQUIPMENT SHALL BE STORED IN A DRY AND PROTECTED AREA. ALL EQUIPMENT SHALL BE STORED IN A DRY AND PROTECTED AREA. ALL EQUIPMENT SHALL BE STORED IN A DRY AND PROTECTED AREA.</li> <li>THE ENGINEER MAY REQUIRE MODIFICATIONS TO THE PAVEMENT MARKING DETAIL SHOWN, INCLUDING EDGE LINES, CENTER LINES AND LANE LINES SHALL BE REMOVED, AS APPLICABLE, PRIOR TO NORMAL TRAFFIC. THE CURRENT STANDARD SPECIFICATIONS AND SUPPLEMENTAL SPECIFICATIONS SHALL APPLY.</li> <li>PROPOSED SIGN SPACING MAY BE MODIFIED AS APPROVED BY THE ENGINEER TO MEET EXISTING FIELD CONDITIONS OR TO PREVENT OBSTRUCTION OF THE MOTORIST'S VIEW OF REMAINING SIGNS.</li> <li>PERMANENT SIGNING THAT CONVEYS A MESSAGE CONTRARY TO THE MESSAGE OF THE TEMPORARY SIGNING AND NOT APPLICABLE TO THE WORKING CONDITIONS SHALL BE COVERED BY THE CONTRACTOR WHEN DIRECTED BY THE ENGINEER.</li> <li>PROPOSED CHANGES IN THE TRAFFIC CONTROL PLAN SHALL BE REVIEWED WITH THE ENGINEER BEFORE CHANGES ARE MADE.</li> <li>THE BID ITEM TRAFFIC CONTROL SHALL INCLUDE THE COST FOR ALL TRAFFIC CONTROL MEASURES REQUIRED BY THE CONTRACTOR EXCEPT FOR THOSE WHICH ARE SEPARATE BID ITEMS OR INCIDENTAL TO OTHER BID ITEMS.</li> <li>THE IOWA DOT SHALL BE NOTIFIED PRIOR TO ANY LANE RESTRICTIONS OR CLOSURES ON HIGHWAY 1.</li> <li>NO LANE CLOSURES WILL BE PERMITTED BETWEEN THE HOURS OF 7:00AM AND 4:00PM.</li> </ol> <p><b>TRAFFIC SIGNAL EQUIPMENT</b></p> <p>TRAFFIC SIGNAL EQUIPMENT ON THIS PROJECT SHALL MATCH CITY SPECIFIED PRODUCTS.</p> <ol style="list-style-type: none"> <li>CONTROLLER: QUISOT/AVANCE ATC</li> <li>VIDEO: MOVIDON SNA/RTV/380 AND VIDEO DETECTION SYSTEM</li> <li>POWER SUPPLY: MOVIDON SNA/RTV/380 AND VIDEO DETECTION SYSTEM</li> <li>WIRING: MOVIDON SNA/RTV/380 AND VIDEO DETECTION SYSTEM</li> <li>RESER: MOVIDON SNA/RTV/380 AND VIDEO DETECTION SYSTEM</li> </ol>

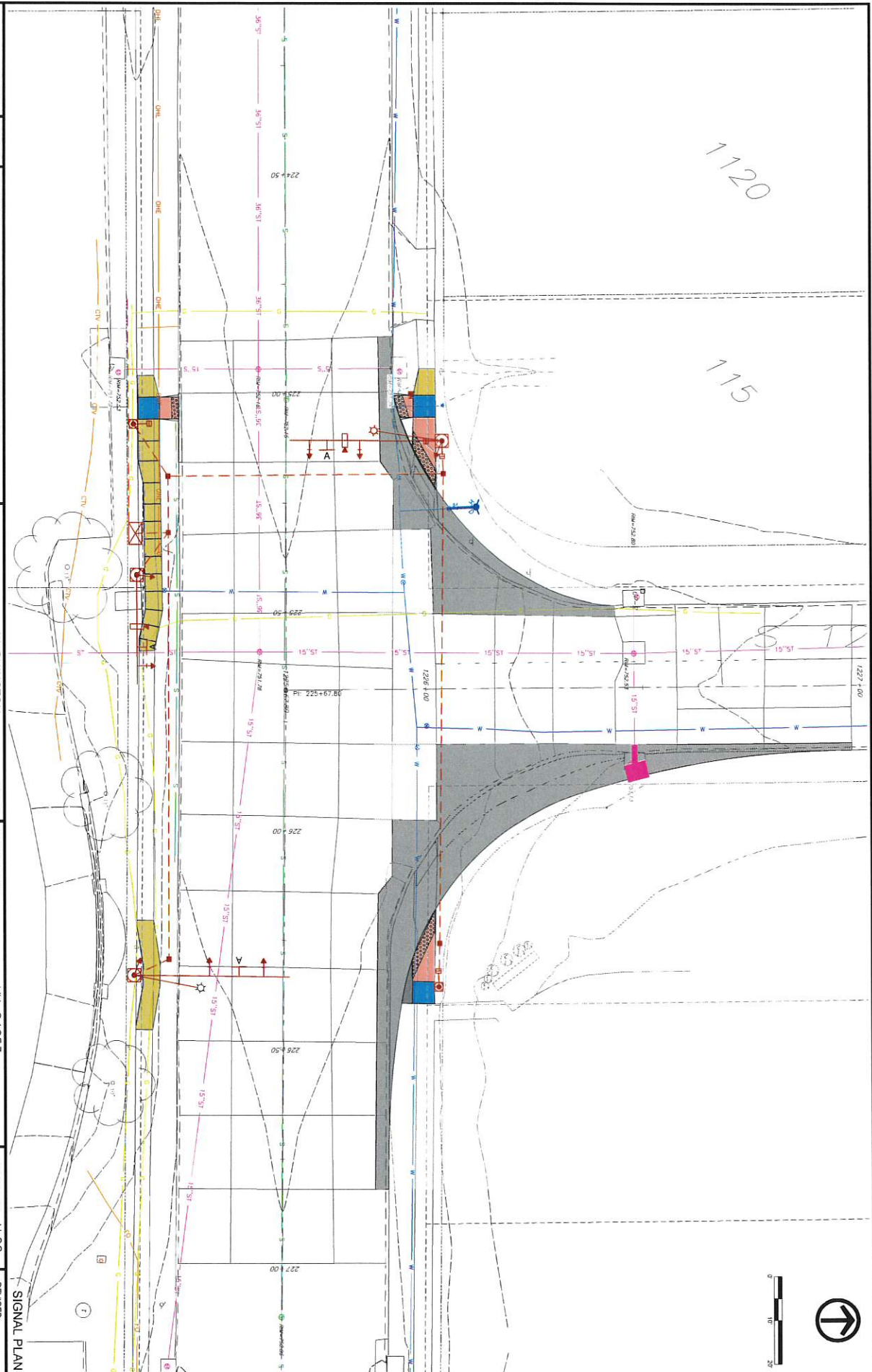

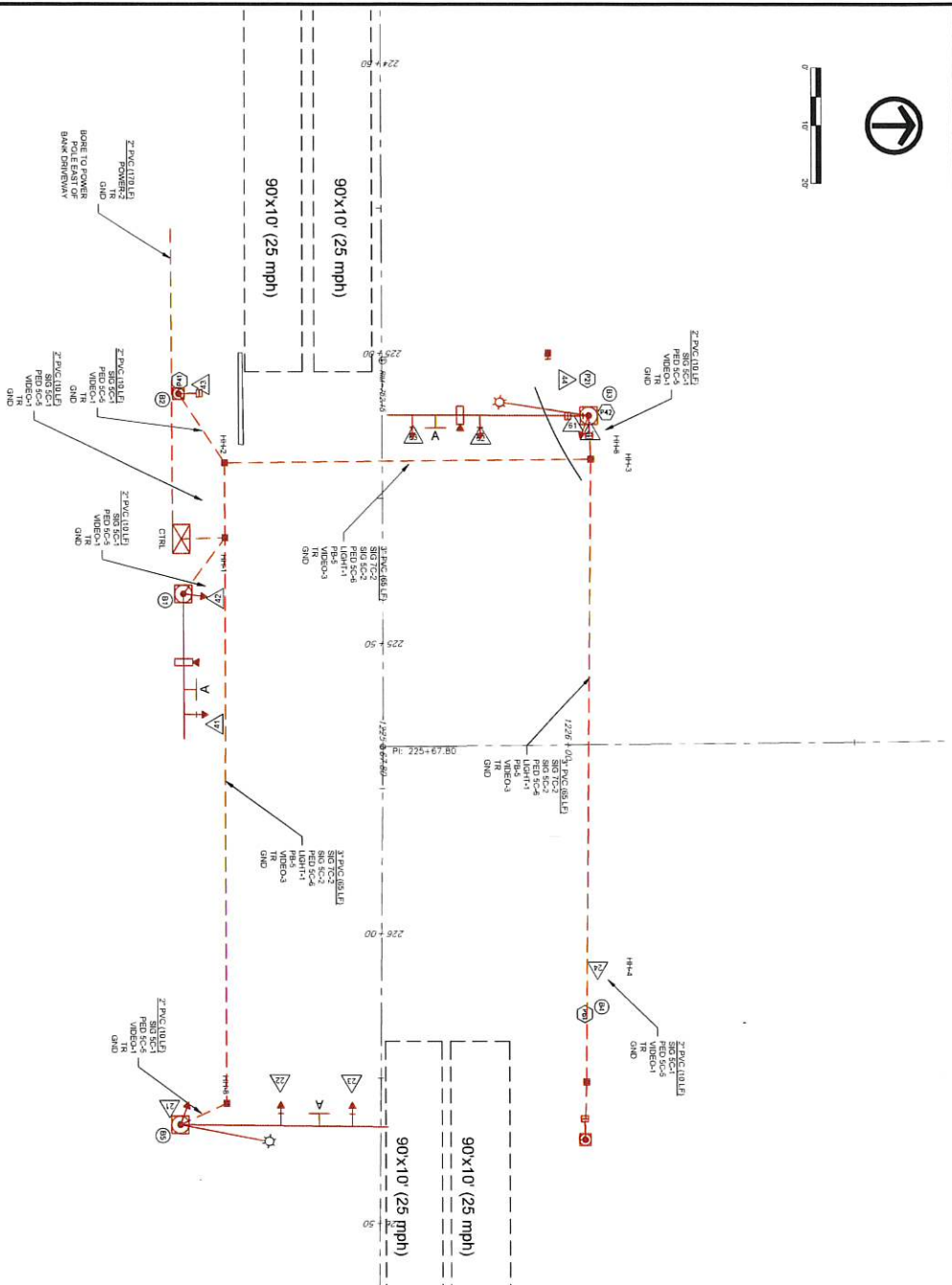

SIGNAL REFERENCE CHART

PHASING DIAGRAM	PROTECTED	PERMITTED	FLASH MODE
<p>Highway 92 12th Street</p> <p>Signal Head</p> <p>▲/▲</p> <p>▲/▲</p> <p>▲/▲</p> <p>▲/▲</p> <p>▲/▲</p>	<p>→</p> <p>→</p> <p>→</p> <p>→</p> <p>→</p>	<p>→</p> <p>→</p> <p>→</p> <p>→</p> <p>→</p>	<p>Y</p> <p>Y</p> <p>Y</p> <p>R</p> <p>R</p>

- (R) 23 21 22
  - (Y) 41 42
  - (G) 61 62 81 82
- SIGNAL FACES

- A** LEFT TURN  
YIELD  
ON FLASHING  
YELLOW  
ARROW
  - B** S 12th Ave
  - C** E. Washington St
  - E** GREEN BACKGROUND  
WITH WHITE LETTERS
- 36" x 42"
- 36" x 42"
- 18" x 18"



PANEL NO	CONDUIT	TYPE		FLOOR		CONDUIT		FLOOR		FLOOR		FLOOR		FLOOR		FLOOR	
		1	2	1	2	1	2	1	2	1	2	1	2	1	2	1	2
20	40																
21	40																
22	40																
23	40																
24	40																
25	40																
26	40																
27	40																
28	40																
29	40																
30	40																
31	40																
32	40																
33	40																
34	40																
35	40																
36	40																
37	40																
38	40																
39	40																
40	40																

**CONDUIT & CABLE**

LOCATION	CONDUIT	TYPE	FLOOR	CONDUIT	FLOOR	CONDUIT	FLOOR	CONDUIT	FLOOR	CONDUIT	FLOOR	CONDUIT	FLOOR	CONDUIT	FLOOR	CONDUIT	FLOOR
20	40																
21	40																
22	40																
23	40																
24	40																
25	40																
26	40																
27	40																
28	40																
29	40																
30	40																
31	40																
32	40																
33	40																
34	40																
35	40																
36	40																
37	40																
38	40																
39	40																
40	40																

**BASIS & PULLBOXES**

**POLES & MAST ARMS**

PAGE NO	REMARKS	TOWER	HEIGHT	TYPE		FLOOR		CONDUIT		FLOOR		FLOOR		FLOOR		FLOOR	
				1	2	1	2	1	2	1	2	1	2	1	2		
20																	
21																	
22																	
23																	
24																	
25																	
26																	
27																	
28																	
29																	
30																	
31																	
32																	
33																	
34																	
35																	
36																	
37																	
38																	
39																	
40																	

**CONTROLLER & EQUIPMENT**

LOCATION	DESCRIPTION	TYPE	REMARKS
	CONTROLLER		
	EQUIPMENT		

**POWER SUPPLY**

STATION	DESCRIPTION	TYPE	REMARKS
	POWER SUPPLY		

**TRAFFIC SIGNAL TIMING**

STATION	DESCRIPTION	TYPE	REMARKS
	TRAFFIC SIGNAL TIMING		

**SIGNAL HEADS**

STATION	DESCRIPTION	TYPE	REMARKS
	SIGNAL HEADS		

DATE: 08/01/03 BY: J. J. KIMM, INC. PROJECT: WASHINGTON COUNTY PROJECT NUMBER: V/K 24653 SHEET NUMBER: N.04 REVISION:

SIGNAL TABULATION

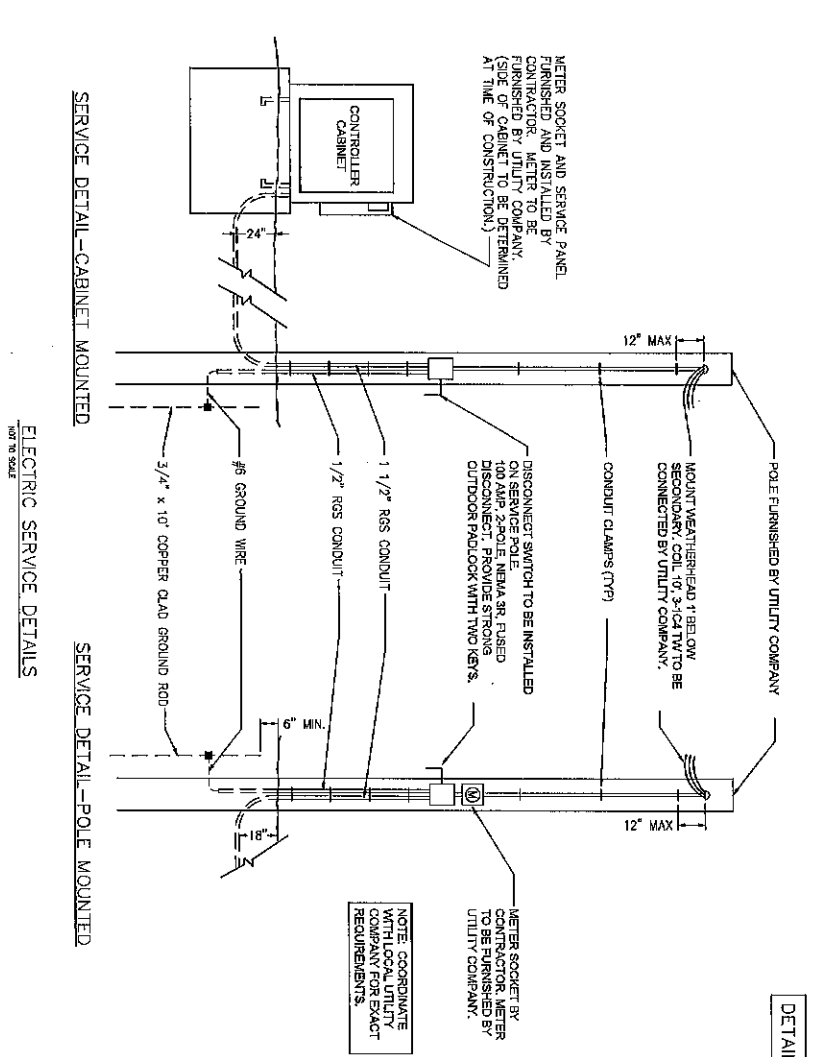

DETAIL E1

METER SOCKET AND SERVICE PANEL FURNISHED AND INSTALLED BY CONTRACTOR. METER TO BE FURNISHED BY UTILITY COMPANY. SIZE OF METER TO BE DETERMINED AT TIME OF CONSTRUCTION.

DISCONNECT SWITCH TO BE INSTALLED ON SERVICE POLE. THE AMP. RATING SHALL BE AS FUSED OUTDOOR PULLBOX WITH TWO KEYS.

METER SOCKET BY CONTRACTOR. METER TO BE FURNISHED BY UTILITY COMPANY.

NOTE: COORDINATE WITH LOCAL UTILITY COMPANY FOR EXACT REQUIREMENTS.

SERVICE DETAIL - CABINET MOUNTED

SERVICE DETAIL - POLE MOUNTED

ELECTRIC SERVICE DETAILS  
NOT TO SCALE

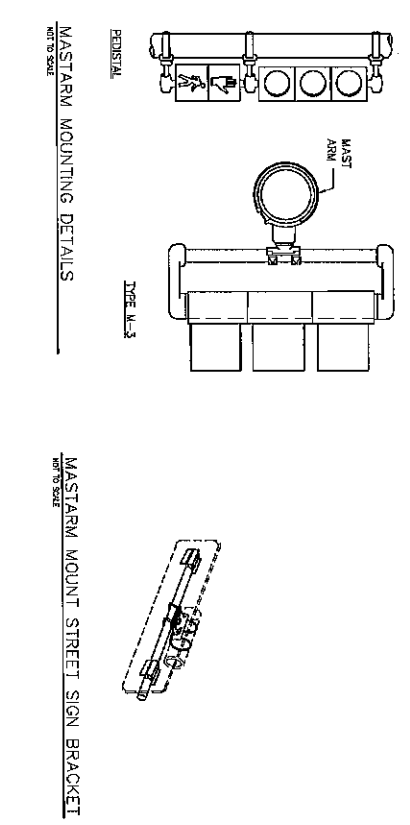
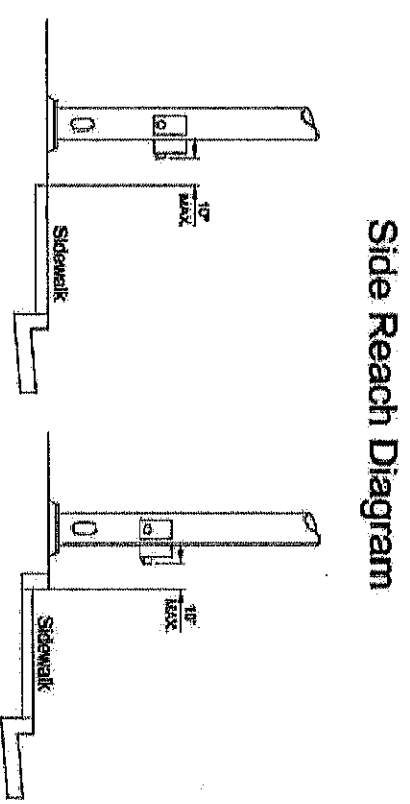
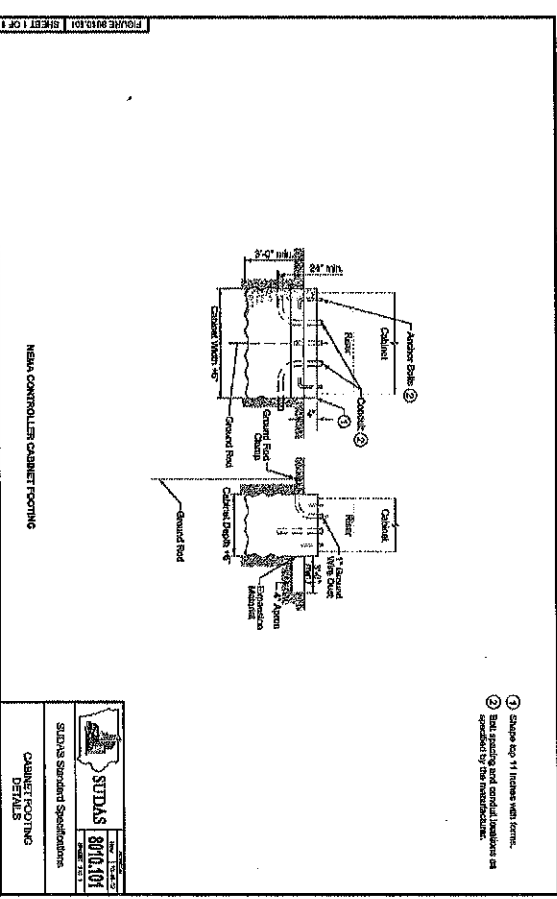
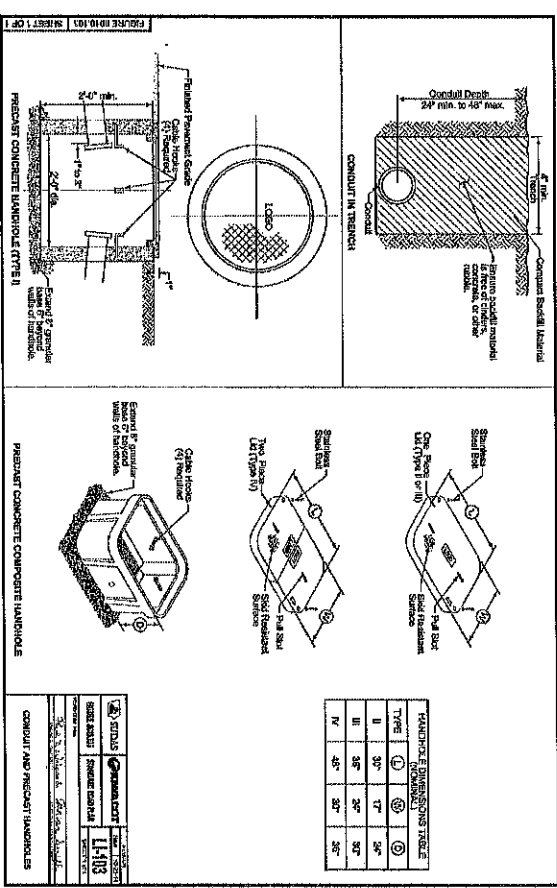

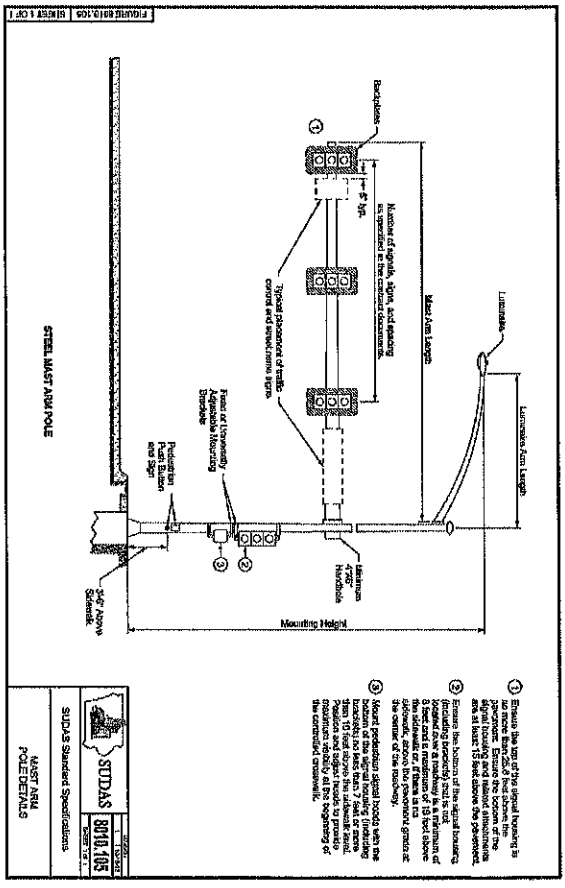

STUDAS 8010.106  
MAY 1993

STUDAS Standard Specifications  
MAST ARM POLE DETAILS

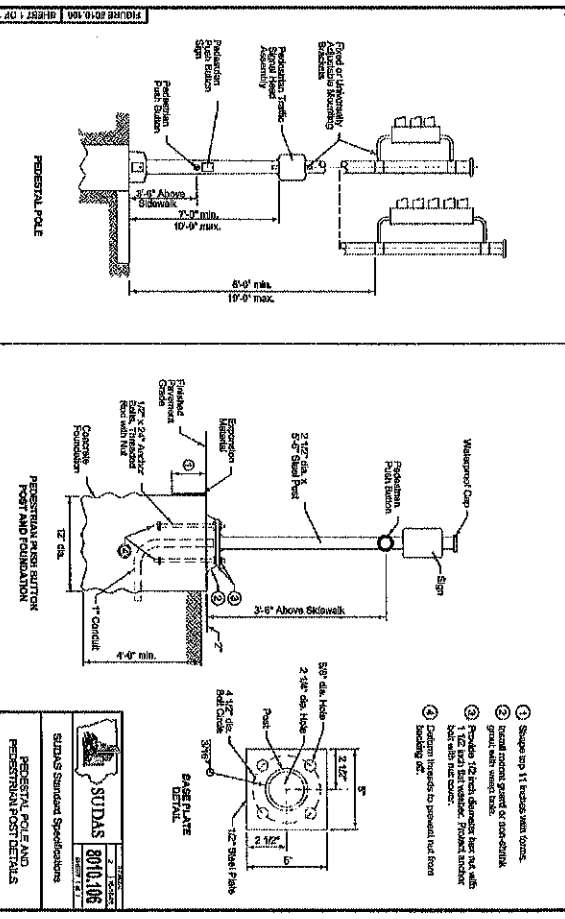

STUDAS 8010.106  
MAY 1993

STUDAS Standard Specifications  
PIERSTAL POLE AND PIERSTAL POST DETAILS

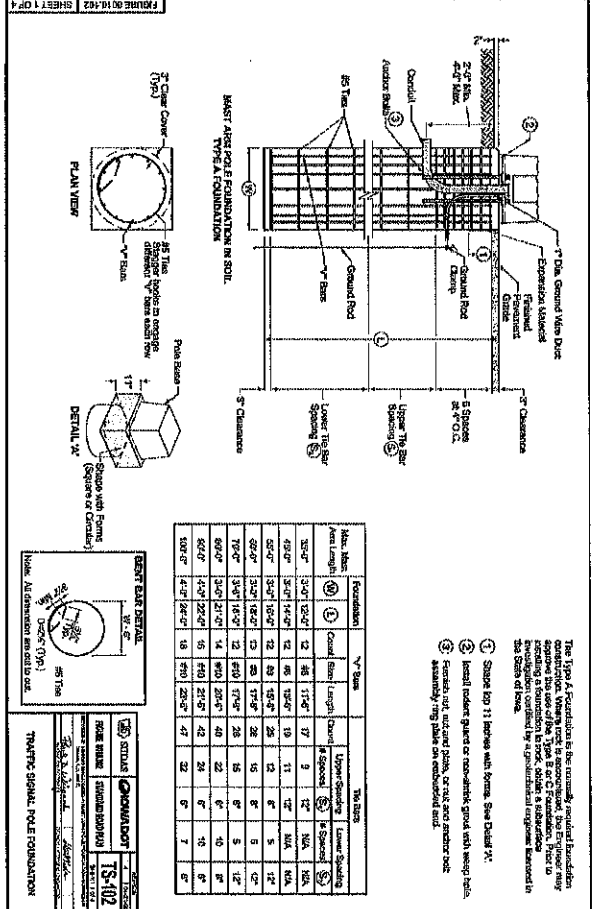

STUDAS 8010.102  
MAY 1993

STUDAS Standard Specifications  
BEST ABET POLE FOUNDATION

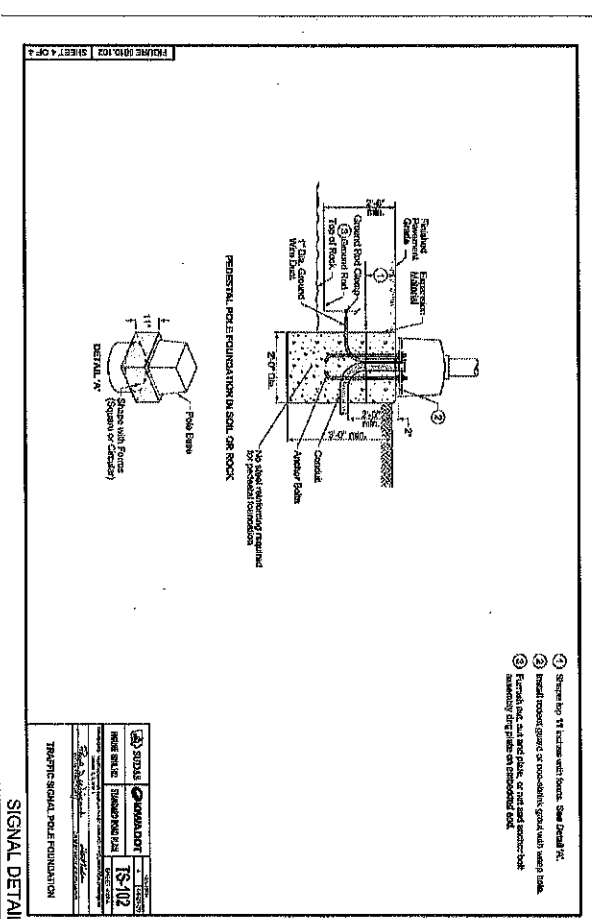

STUDAS 8010.102  
MAY 1993

STUDAS Standard Specifications  
PIERSTAL POLE FOUNDATION

- If possible, inspect wires in the cabinet and traffic pole for any unsafe wear and replace them if necessary.

### Mounting the Camera

1. In a bucket truck, gather:
  - SmartView 360 components (including camera assembly, couplers and connectors)
  - 19 mm (3/4 in) stainless steel banding and a banding tool.
3. Raise the bucket to the height where you plan to install the SmartView 360.
4. If you are installing on a traffic pole using two lengths of stainless steel banding, mount the SmartView 360 to the traffic pole at a height of 2.14 m (60 ft) or higher.
5. Rotate the SmartView 360 so that it points toward the center of the intersection, free of visual obstructions.
6. After the SmartView 360 is in position, tighten the socket nuts with a 8 mm (5/16 in) socket wrench.

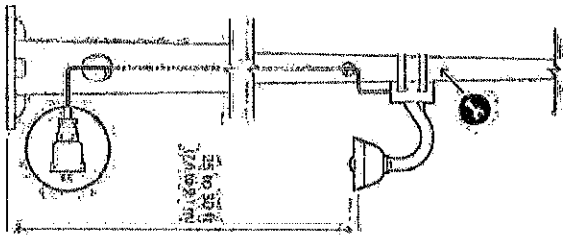

7. Run the shielded Ethernet cable through the hole in the traffic pole, leaving 1 to 1.2 m (3 to 4 ft) of slack to follow proper drip loop procedure. Note: You might need to remove a pole grommet temporarily to allow the Ethernet coupler to fit through.

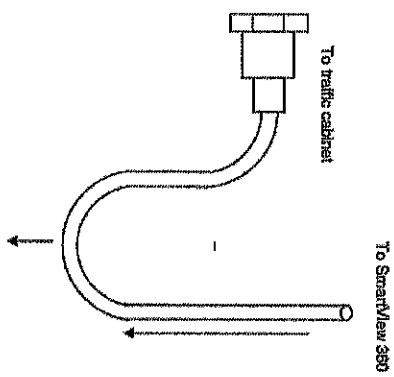

*Depiction of drip loop. Rain water may run down the cable from the camera at the right. The drip loop provides a natural and safe spot for water to drain.*

8. At the traffic cabinet, cut the Ethernet cable to the appropriate length and then install and crimp the RJ45 connector. Make sure that the drain wire contains the shielded connector housing.

### In-Cabinet Installation

Follow the steps in the [TraficLink Hardware Installation Manual](#) to install the Miovision Core or Miovision Core DCM.

Opinion of Cost for  
4 to 3 Lane Conversion and Traffic Signals  
Washington, Iowa  
5/9/2023

No.	Item	Description	Unit	Unit Price	HSP		USTEP		CITY		Project Total Cost
					Quantity	Division I Cost	Quantity	Division II Cost	Quantity	Division III Cost	
1	2102-2710070	EXCAVATION, CL 10, RDWAY+BORROW	CY	\$50.00	0	\$0.00	215	\$10,750.00	435	\$21,750.00	\$32,500.00
2	2102-2713080	EXCAVATION, CL 13, WASTE	CY	\$50.00	0	\$0.00	0	\$0.00	108	\$5,400.00	\$5,400.00
3	2105-8429005	TOPSOIL, FURN+SPREAD	CY	\$100.00	0	\$0.00	10	\$1,000.00	75	\$7,500.00	\$8,500.00
4	2115-0100000	MODIFIED SUBBASE	CY	\$100.00	0	\$0.00	81	\$8,100.00	26	\$2,600.00	\$10,700.00
5	2121-7425010	GRANULAR SHLD, TYPE A	TON	\$50.00	0	\$0.00	0	\$0.00	78	\$3,900.00	\$3,900.00
6	2213-8201080	BASE WIDENING, 6" HMA	SY	\$90.00	0	\$0.00	0	\$0.00	545	\$49,050.00	\$49,050.00
7	2301-1033080	STD/S-F PCC PAVT, CL C CL 3, 8"	SY	\$100.00	0	\$0.00	288	\$28,800.00	8	\$800.00	\$29,600.00
8	2303-1041500	HMA HT BASE, 1/2"	TON	\$65.00	0	\$0.00	0	\$0.00	112	\$7,280.00	\$7,280.00
9	2303-1258284	ASPH BINDER, PG 58-28H	TON	\$65.00	0	\$0.00	0	\$0.00	7	\$4,550.00	\$4,550.00
10	2401-8745910	RMVL OF SIGN	EACH	\$200.00	0	\$0.00	0	\$0.00	0	\$0.00	\$0.00
11	2435-024100	INTAKE, SW-541	EACH	\$9,000.00	0	\$0.00	0	\$0.00	1	\$9,000.00	\$9,000.00
12	2503-0114215	STORM SWR G-MAIN, TRENCHED, RCP 2000D, 15"	LF	\$40.00	0	\$0.00	0	\$0.00	5	\$200.00	\$200.00
13	2510-6745880	RMVL OF PAVT	SY	\$100.00	0	\$0.00	152	\$6,080.00	28	\$1,120.00	\$7,200.00
14	2510-6730800	RMVL OF INTAKE+UTILITY ACCESS	EACH	\$1,000.00	0	\$0.00	0	\$0.00	1	\$1,000.00	\$1,000.00
15	2511-6745900	RMVL OF SIDEWALK	SY	\$20.00	0	\$0.00	69	\$1,380.00	0	\$0.00	\$1,380.00
16	2511-7528004	SIDEWALK, PCC, 4"	SY	\$80.00	0	\$0.00	41	\$2,460.00	0	\$0.00	\$2,460.00
17	2511-7528006	SIDEWALK, PCC, 6"	SY	\$80.00	0	\$0.00	0	\$0.00	223	\$17,840.00	\$17,840.00
18	2511-7528008	SIDEWALK, PCC, 8"	SY	\$100.00	0	\$0.00	27	\$2,700.00	0	\$0.00	\$2,700.00
19	2511-7528101	DETECTABLE WARNING	SF	\$50.00	0	\$0.00	40	\$2,000.00	0	\$0.00	\$2,000.00
20	2524-9256010	POST, STEEL	EACH	\$125.00	0	\$0.00	3	\$375.00	0	\$0.00	\$375.00
21	2524-9329001	TYPE A SIGN, SHEET ALUM	SF	\$25.00	0	\$0.00	14	\$350.00	0	\$0.00	\$350.00
22	2525-0000100	TRAFFIC SIGNALIZATION	LS	\$185,000.00	0	\$0.00	1	\$185,000.00	0	\$0.00	\$185,000.00
23	2526-8286000	CONSTRUCTION SURVEY	LS	\$50.00	0	\$0.00	0	\$0.00	0	\$0.00	\$0.00
24	2527-923112	PAINTED PAVT MARK HIGH-BUILD WATERBORNE	STA	\$24,700.00	0	\$0.00	1	\$24,700.00	0	\$0.00	\$24,700.00
25	2527-923138	PAINTED SYMBOL+LEGEND, HIBUILD WATERBORNE	STA	\$175.00	0	\$0.00	0	\$0.00	0	\$0.00	\$0.00
26	2527-923180	PAVT MARK RMVD	STA	\$50.00	0	\$0.00	0	\$0.00	0	\$0.00	\$0.00
27	2527-923190	SYMBOL+LEGEND RMVD	EACH	\$100.00	20	\$2,000.00	0	\$0.00	0	\$0.00	\$2,000.00
28	2527-9270111	GROOVE CUT - PAVT MARK	STA	\$35.00	494	\$17,290.00	0	\$0.00	0	\$0.00	\$17,290.00
29	2528-9445110	TRAFFIC CONTROL	LS	\$25,000.00	0	\$0.00	1	\$25,000.00	0	\$0.00	\$25,000.00
30	2533-4980005	MOBILIZATION	LS	\$30,000.00	0	\$0.00	1	\$30,000.00	0	\$0.00	\$30,000.00
31	2554-0210201	FIRE HYDRANT ASSEMBLY, WM-201	EACH	\$10,000.00	0	\$0.00	0	\$0.00	1	\$10,000.00	\$10,000.00
32	2554-0210205	FIRE HYDRANT ASSEMBLY REMOVAL	EACH	\$1,000.00	0	\$0.00	0	\$0.00	0	\$0.00	\$0.00
33	2601-2634100	MULCH	ACRE	\$6,000.00	0	\$0.00	0	\$0.00	0	\$0.00	\$0.00
34	2601-2636044	SEED+FERTILIZE (URBAN)	ACRE	\$6,000.00	0	\$0.00	0	\$0.00	0	\$0.00	\$0.00
35	2602-0000500	OPEN-THROAT CURB INTK SED FLT, EC-802	LF	\$125.00	0	\$0.00	40	\$5,000.00	0	\$0.00	\$5,000.00
36	2602-0000510	MAINT OF OPEN-THRT CURB INTK SDMMNT FLTR	EACH	\$40.00	0	\$0.00	4	\$160.00	0	\$0.00	\$160.00
37	2602-0000520	RMVL OF OPEN-THRT CURB INTK SDMMNT FLTR	EACH	\$125.00	0	\$0.00	4	\$500.00	0	\$0.00	\$500.00
Subtotal					\$87,440.00			\$353,055.00		\$147,510.00	\$588,005.00
Contingency								10%			\$58,800.00
<b>Construction Total</b>											<b>\$646,805.00</b>



## Application – HSIP-Local Program – FY 2024

(Please fill out one application per project)

**General Information:**

Agency: City of Washington  
 Contact Person: Deanna McCusker, City Administrator  
 Phone Number: 319-653-6584  
 Email Address: dmccusker@washingtونيowa.gov

**The County/City is interested in seeking HSIP-Local (formerly called HSIP-Secondary) ‘Swap’ funding for the following type of project (check all that apply):**

Road Segments			Intersections / Curves		
Improvement Type		CRF*-%	Improvement Type		CRF-%
<input type="checkbox"/>	Centerline Rumble Strips	10%	<input type="checkbox"/>	Transverse Rumble Strips	13%
<input type="checkbox"/>	Pave Shoulders and Install Rumble Strips	15%	<input type="checkbox"/>	Clearing and Grubbing	varies
<input type="checkbox"/>	Shoulder or Edgeline Rumble Strips	15%	<input type="checkbox"/>	Signs (new only)	varies
<input type="checkbox"/>	Grooved-in 6" Pavement Markings	7-10%	<input type="checkbox"/>	Curve Warning and Chevron Signs	10-20%
<input type="checkbox"/>	Clearing and Grubbing	varies	<input type="checkbox"/>	Pedestrian/Bike Improvements**	varies
<input type="checkbox"/>	Signs (new only)	varies	<input type="checkbox"/>	Speed Management	varies
<input type="checkbox"/>	Guardrail (new or upgraded)	varies	<input checked="" type="checkbox"/>	Lane Reconfiguration-Pvmt Mkgs***	varies
<input type="checkbox"/>	Other:			Other:	

\* Iowa DOT Planning Level Crash Reduction Factor (CRF) for reference ([link for additional CRFs and info \(July 2019\)](#))

\*\* Likely projects include: enhanced crossing signing/markings/curb with RRFBs and PHBs (aka HAWK signals)

\*\*\*Likely projects include 4-lane to 3-lane conversions or similar access/turn lane reconfigurations.

**Project Details:**

Targeted letting fiscal year: 2024 (HSIP-Local ‘Swap’ projects must be let through Iowa DOT)

Estimated funding request: \$87,440

4-3 lane conversion on IA 92 from S 2<sup>nd</sup> Ave to ECL/Wiley Avenue.  
 Corridor identified in the Iowa DOT 2017 “Statewide Screening for Potential Lane Reconfiguration” and IA 92 & S 12<sup>th</sup> Avenue TEAP study. Project to be tied with intersection improvement project at S 12<sup>th</sup> Avenue.

**Additional Project Safety Documentation:**

- Attach Project information sheet(s) included in the City or County’s Local Road Safety Plan,
- Attach other project specific safety analysis (e.g. Benefit/Cost), data, cross sections/photos, etc. to assist evaluation
- Project intersection or segment of High or Medium PCR Level from the Iowa DOT Potential for Crash Reduction (PCR) tool <https://pcr.iowadot.gov/>

Potential for Crash Reduction (PCR) Information					
Intersection ID (1234567890) or Segment ID (1234)	Intersection or Segment	High Level	Medium Level	PCR- All (cr/yr)	PCR- Severe (cr/yr)
2017143707	IA 92 (S 2 <sup>nd</sup> Ave) & E Jefferson St	<input type="checkbox"/>	<input checked="" type="checkbox"/>	0.37	
2017143710	IA 92 (E Washington St) & S 7 <sup>th</sup> Ave	<input type="checkbox"/>	<input checked="" type="checkbox"/>	0.28	0.08
2017081290	IA 92 (E Washington St) & S 12 <sup>th</sup> Ave	<input checked="" type="checkbox"/>	<input type="checkbox"/>	1.06	
2017081291	IA 92 (E Washington St) & Airport Rd	<input type="checkbox"/>	<input checked="" type="checkbox"/>	0.29	

**This application does not obligate the Agency or Iowa DOT to utilize HSIP-Local funds on the identified project.**

Please submit application to Traffic and Safety Bureau – Safety Programs Engineer - Greg Karssen  
[Greg.Karssen@iowadot.us](mailto:Greg.Karssen@iowadot.us) (515) 239-1267

*Millie Youngquist, Mayor Pro Tem  
Deanna McCusker, City Administrator  
Kelsey Brown, Finance Director  
Sally Hart, City Clerk  
Kevin Olson, City Attorney*



*City of Washington  
215 East Washington Street  
Washington, Iowa 52353  
(319) 653-6584 Phone  
(319) 653-5273 Fax*

---

May 8, 2023

Bob Younie, P.E.  
District Engineer, District 5  
Iowa Department of Transportation  
205 E. 227th Street  
Fairfield, IA 52556

Dear Mr. Younie,

The City of Washington is pleased to submit an application for a USTEP grant for a project on Iowa Highway 92. The project consists of two components: the conversion of IA 92 from an urban 4-lane to a 3-lane section with bike lanes and the construction of a traffic signal at the intersection of IA 92 (E. Washington St.) & N. 12th Avenue.

The 3-lane conversion of Iowa Highway 92 through the City of Washington has been identified by the Iowa Department of Transportation as a priority project. The Iowa Department of Transportation previously converted the western half of IA 92 (Madison St) into a 3-lane section. This project will complete the 3-lane conversion through the City. The City will be seeking HSIP funds for the restriping and signage.

The intersection of IA 92 & N. 12th Ave is a major truck route and N. 12th Ave is a designated Farm-To-Market route. During fall harvest, the southbound trucks have difficulty finding gaps in the Highway 92 traffic when trying to make a left turn. It has been observed that during peak hours, the traffic will back up to the north to the railroad tracks that are five blocks away. The westbound right turning trucks have difficulty in making the turn with the existing geometry and the trailers overtrack and are creating ruts in the greenspace behind the curb.

The project will widen the northwest and northeast curb returns to allow for right turning trucks to not jump the curb. As a part of the widening, an existing fire hydrant and storm intake will need to be relocated. A traffic signal will be installed with video detection and an ADA crossing will be constructed across IA 92 on the west side of 12th Ave. This crossing will provide improved access to the community for the Halcyon assisted living facility immediately to the south of the project. No permanent right-of-way is required but there will be temporary construction easements.

*"One of the 100 Best Small Towns in America"*



Enclosed with this letter are concept plans and a cost opinion. The cost opinion is divided into three divisions for the three funding sources, HSIP, USTEP, and City.

Please contact me for any administrative questions. For technical questions, please contact Leland Belding from Veenstra & Kimm, Inc. in Coralville at 319-466-1000 or lbelding@v-k.net.

Sincerely,

Deanna McCusker  
City Administrator, City of Washington

Enclosure

**Opinion of Cost for  
Washington and 12th Traffic Signal  
Washington, Iowa  
2/12/2023**

No.	Item	Description	Unit	Unit Price	Quantity	Option #1		Option #2	
						Extended Price	Signal & Widening	Extended Price	
1	2102-2710090	EXCAVATION, CL 10, WASTE	CY	\$50.00	30	\$1,500.00	50	\$2,500.00	
2	2105-8425005	TOPSOIL, FURN+SPREAD	CY	\$100.00	10	\$1,000.00	30	\$3,000.00	
3	2115-0100000	MODIFIED SUBBASE	CY	\$100.00	30	\$3,000.00	50	\$5,000.00	
4	2301-1033080	STD/S-F PCC PAVT, CL C CL 3, 8"	SY	\$100.00	40	\$4,000.00	260	\$26,000.00	
5	2401-6745910	RMVL OF SIGN	EACH	\$200.00	1	\$200.00	3	\$600.00	
6	2435-0254100	INTAKE, SW-541	EACH	\$6,000.00	0	\$0.00	1	\$6,000.00	
7	2503-0114215	STORM SWR G-MAIN, TRENCHED, RCP 2000D, 15"	LF	\$1,000.00	0	\$0.00	5	\$5,000.00	
8	2510-6745850	RMVL OF PAVT	SY	\$40.00	10	\$400.00	160	\$6,400.00	
9	2510-6750600	RMVL OF INTAKE+UTILITY ACCESS	EACH	\$500.00	0	\$0.00	1	\$500.00	
10	2511-6745900	RMVL OF SIDEWALK	SY	\$40.00	70	\$2,800.00	80	\$3,200.00	
11	2511-7526004	SIDEWALK, PCC, 4"	SY	\$60.00	40	\$2,400.00	40	\$2,400.00	
12	2511-7526008	SIDEWALK, PCC, 8"	SY	\$100.00	25	\$2,500.00	25	\$2,500.00	
13	2525-0000100	DETECTABLE WARNING	SF	\$50.00	40	\$2,000.00	40	\$2,000.00	
14	2526-8285000	TRAFFIC SIGNALIZATION	LS	\$185,000.00	1	\$185,000.00	1	\$185,000.00	
15	2527-9263109	CONSTRUCTION SURVEY	LS	\$7,000.00	1	\$7,000.00	1	\$7,000.00	
16	2527-9263180	PAINTED PAVT MARK, WATERBORNE/SOLVENT	STA	\$200.00	13.5	\$2,700.00	15.0	\$3,000.00	
17	2528-8445110	PAV'T MARK RMVD	STA	\$1,000.00	1.0	\$1,000.00	1.0	\$1,000.00	
18	2533-4980005	TRAFFIC CONTROL	LS	\$10,000.00	1	\$10,000.00	1	\$15,000.00	
19	2554-0210201	MOBILIZATION	LS	\$25,000.00	1	\$25,000.00	1	\$30,000.00	
20	2554-0210205	FIRE HYDRANT ASSEMBLY, WM-201	EACH	\$7,000.00	0	\$0.00	1	\$7,000.00	
21	2601-2634100	FIRE HYDRANT ASSEMBLY REMOVAL	EACH	\$1,000.00	0	\$0.00	1	\$1,000.00	
22	2601-2636044	MULCH SEED+FERTILIZE (URBAN)	ACRE	\$6,000.00	0.1	\$600.00	0.2	\$1,200.00	

Subtotal \$245,200.00  
 Contingency 10% \$24,500.00  
**Construction Total \$269,700.00**

Subtotal \$288,000.00  
 Contingency \$28,800.00  
**Construction Total \$316,800.00**

DATE	REVISIONS	SCALE	AS NOTED
		DRAWN	DWH
		CHECKED	LJB
		APPROVED	LJB
		DATE	02/02/23
		DESIGNED FOR	VEENSTRA & KIMM INC.

  

12TH AVE AND WASHINGTON ST TRAFFIC SIGNAL	
CITY OF WASHINGTON	
2008 University Parkway, Suite 300	Cambridge, MA 02142
315-429-1400	315-429-1400 (EXT. 283)
	888-511-6800 (TOLL FREE)

OPTION #1	DWG. NO.
SIGNAL PLAN	N.02A
EXISTING GEOMETRY	PROJECT
	24653



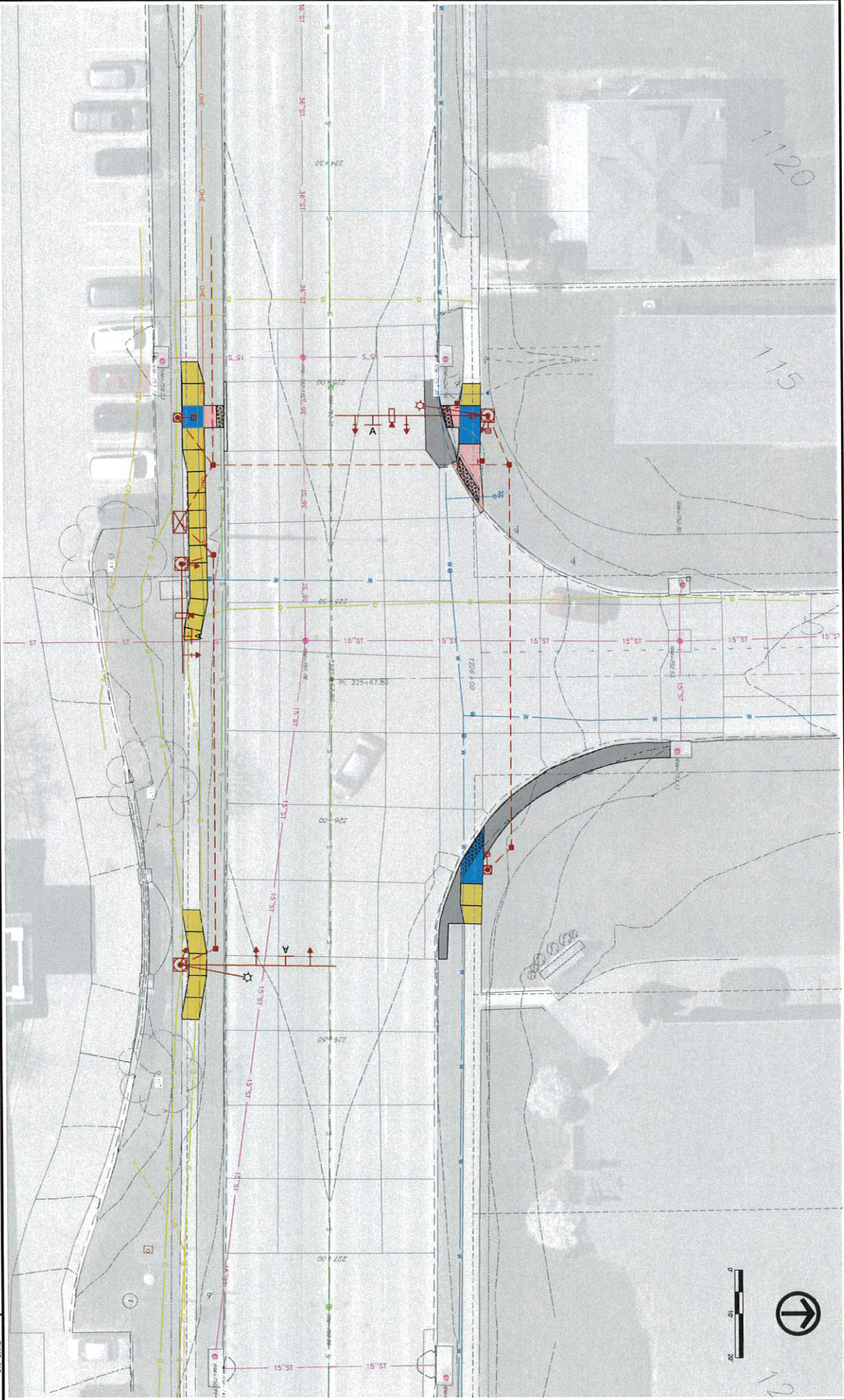

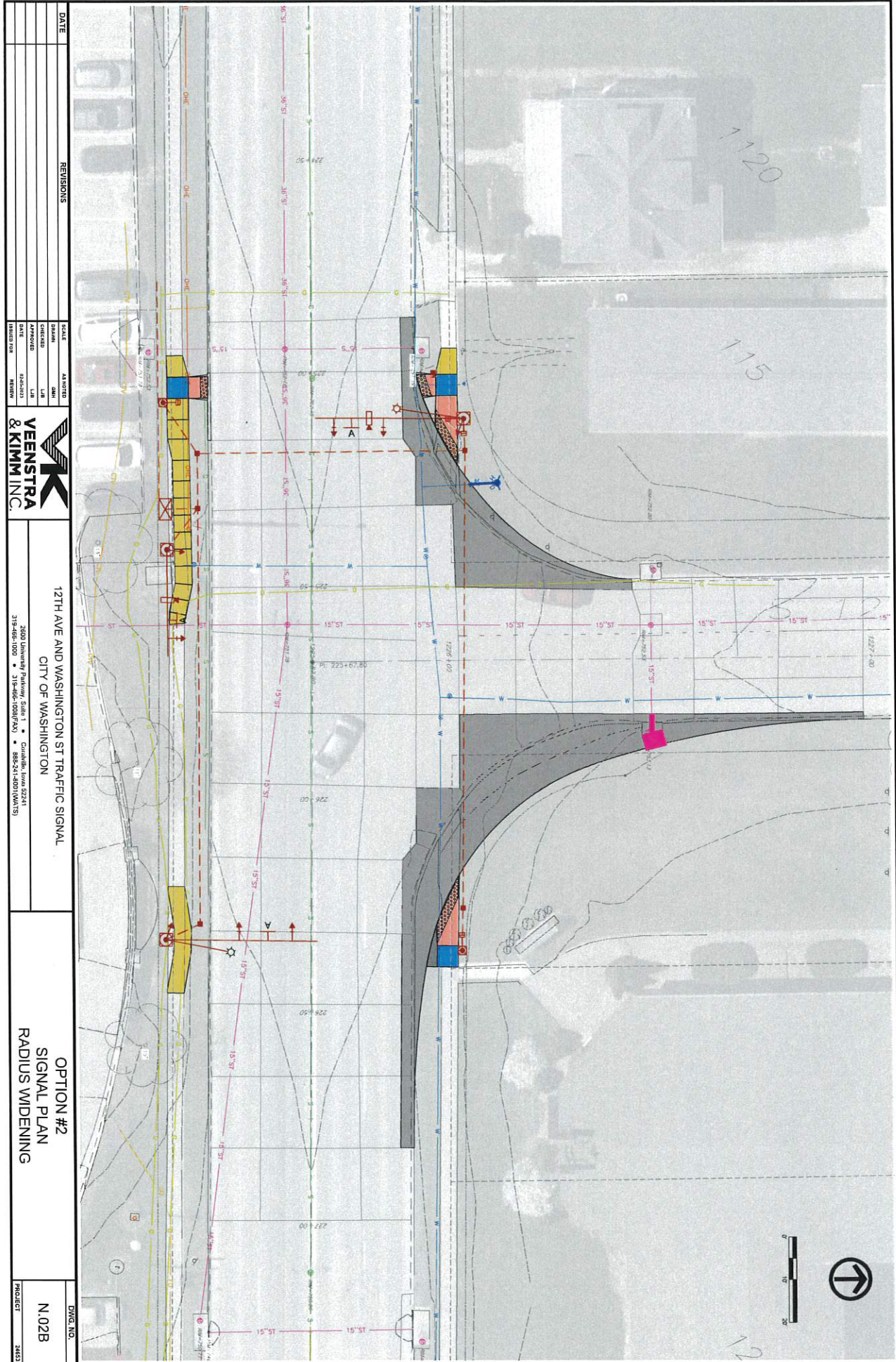
DATE	REVISIONS	SCALE	AS NOTED
		CHECKED	DATE
		APPROVED	DATE
		DESIGNED	DATE
		REVIEW	DATE

<p><b>VEENSTRA &amp; KIMMING</b></p> <p>2600 University Parkway, Suite 1 • Columbia, Iowa 52241                  319-486-1000 • 319-486-1080 • 319-486-1081 • 319-486-1082</p>	<p><b>12TH AVE AND WASHINGTON ST TRAFFIC SIGNAL</b></p> <p>CITY OF WASHINGTON</p>	<p><b>OPTION #2</b></p> <p><b>SIGNAL PLAN</b></p> <p><b>RADIUS WIDENING</b></p>	<p>DWG. NO.</p> <p><b>N.02B</b></p> <p>PROJECT</p> <p>24653</p>
--	---	---	---

## LICENSE AGREEMENT FOR COMMUNITY GARDENS

THIS LICENSE AGREEMENT (the "Agreement") entered into by and between the City of Coralville, Iowa, (hereafter the "City"); and PLANT Washington, Inc. (hereafter the "Plant").

WHEREAS, the City is the owner of real property generally described as Washington County Assessor No. 1120104001 (the "Property"); and

WHEREAS, Plant has approached the City about using a portion of the Property for the establishment and maintenance of community gardens on the Property; and

WHEREAS, the City has agreed to grant the Plant a Revocable License Agreement to allow Plant to use the Property for the establishment and maintenance of community gardens, subject to the terms and conditions below.

1. Grant of License. The City hereby grants to Plant, a nonexclusive revocable license to allow for the establishment and maintenance of community gardens overseen by Plant on the Property to be used by residents of the City of Washington.

2. Term of License. This License Agreement will be for an annual basis and end as of 11:59 p.m. on December 31, 2023. However, said license shall automatically be renewed for another calendar year unless either party gives written notice to terminate this License Agreement by December 1<sup>st</sup> of each year the license remains in effect.

3. City Use. During the term of this Agreement, the City shall have the right to use the Property as long as the City's use does not interfere with the intended use of Plant.

4. Termination of License prior to expiration. In the event that Plant does not keep the operate or maintain the community gardens on the Property, this license shall immediately cease.

5. Effect of Termination. Upon termination of this License Agreement, Plant shall vacate the Property and remove all personal property, including all vegetation, from the Property. Any personal property remaining on the Property, including any trees, shall be deemed the property of the City after the License Agreement is terminated.

6. Agreements with users. Plant shall enter into an agreement with each citizen of Washington that wants to use a plot of the community garden. Said agreements shall contain a

statement that the user indemnifies the City of Washington against any liability for injuries or property damage that occurs as a result of the user using the plot at the community gardens.

7. Indemnification. Plant shall save, defend and hold the City, its employees, elected and appointed officials and agents, harmless from any and all claims associated with the use of the Property under this Agreement.

8. Insurance. Plant shall provide the City with a certificate of insurance naming the City as an additional insured on its general liability policy in the amount of not less than \$1,000,000.00 for any and all claims for damages because of the use of the Property by Plant. Said certificate of insurance shall provide thirty (30) days' notice of cancellation.

IN WITNESS WHEREOF, this instrument is executed this \_\_\_\_ day of \_\_\_\_\_, 2023.

PLANT:

CITY:

By: \_\_\_\_\_

\_\_\_\_\_  
\_ Millie Youngquist, Mayor Pro tem

\_\_\_\_\_  
Print name and title

24 trees in orchard 15'x15' spacing

12 10'x20' garden spots  
or 24 10'x10'

NA

1" = 20'

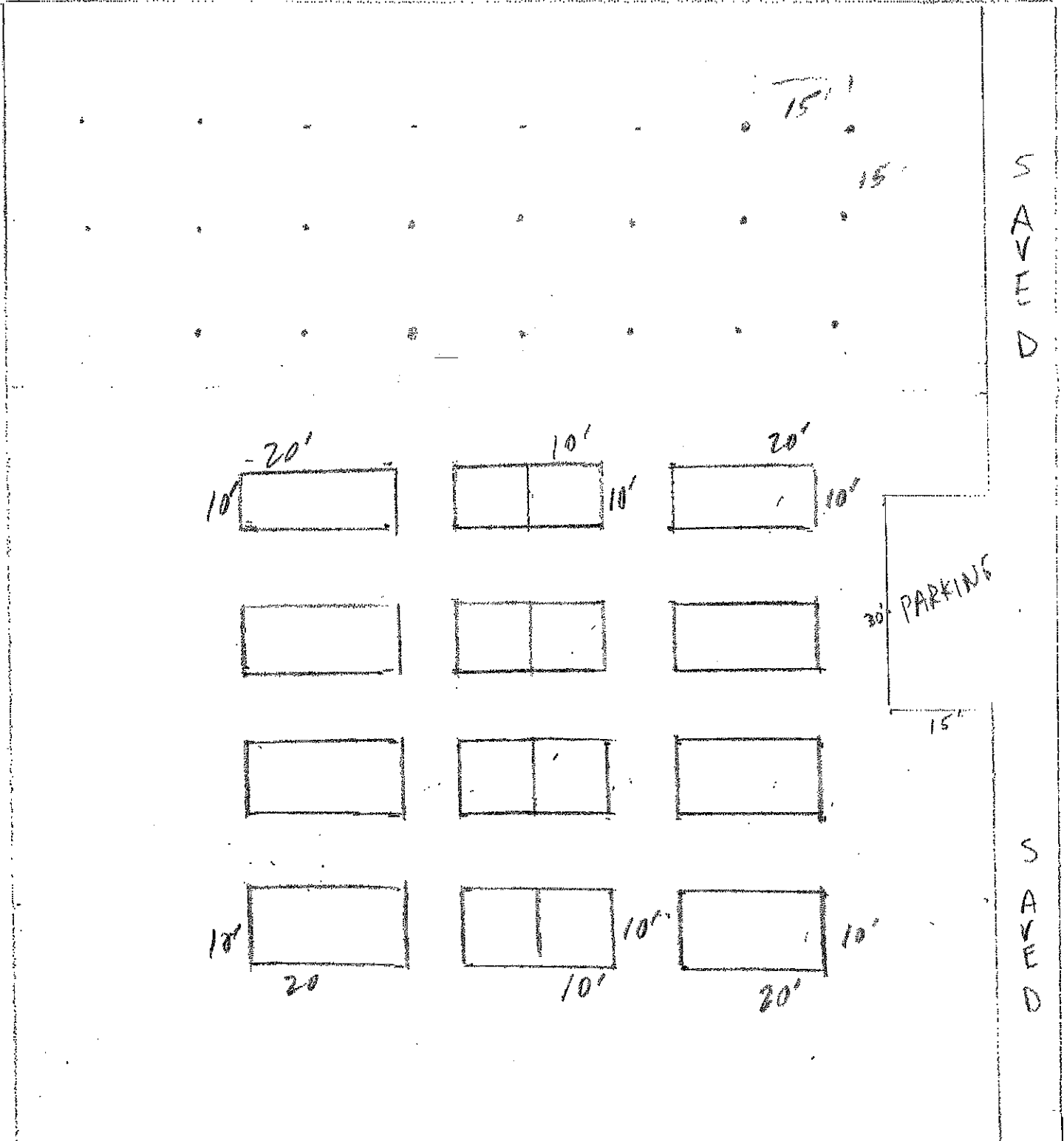

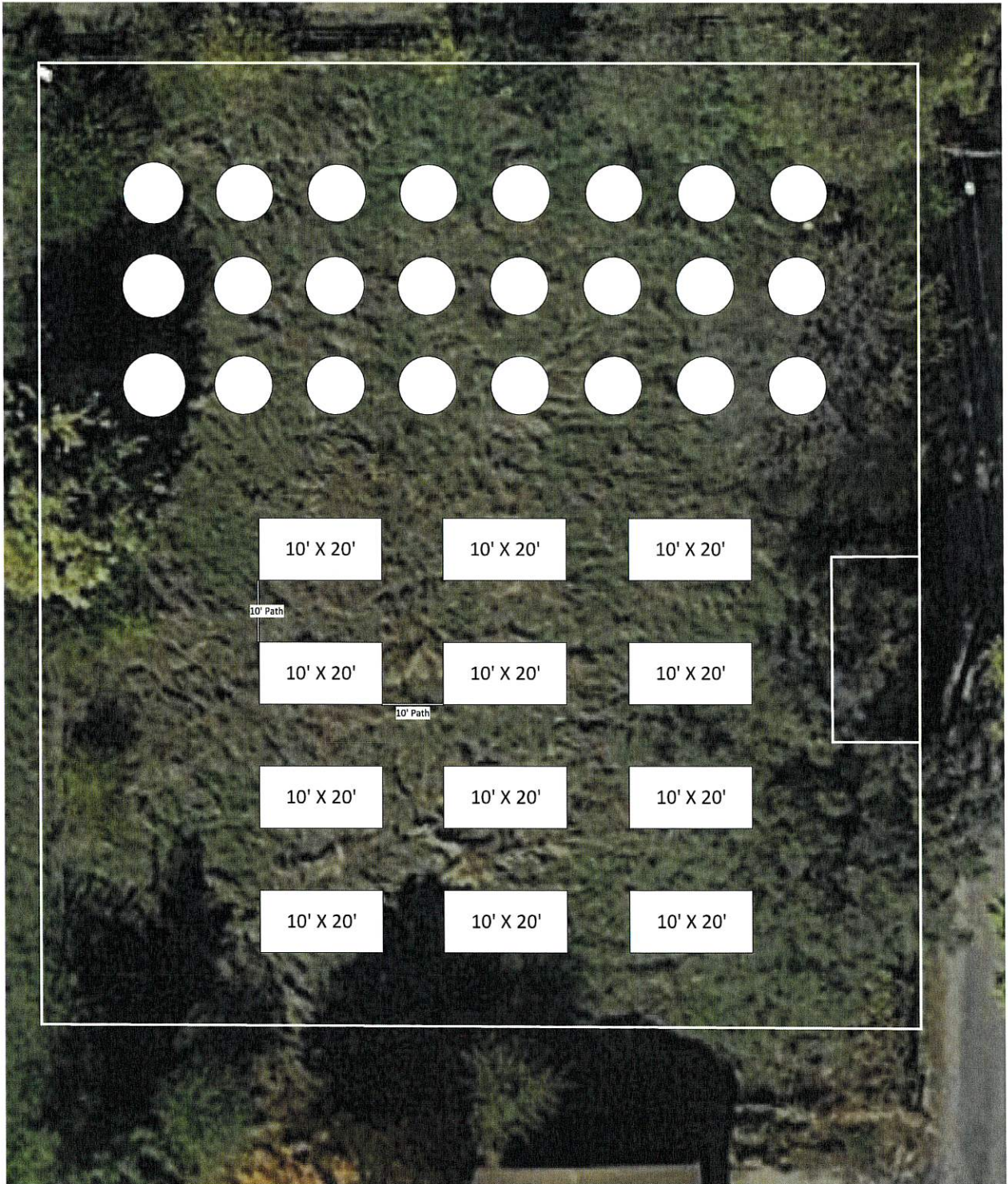





Updated: March 16,

2023

# PLANT Washington--Community Orchards a

Eat Well Action Plan



POWERED BY Wellmark

**Tactic:**

- Community Garden and Orchard

**Outcomes:**

- Increase access to and consumption of healthy food.
- Build community connections through food, conversation, and learning.

**Champions:**

- Andy Dahl
- Lydia Davis
- Sarah Dawson
- Cindy Rico Chavez
- Kerrie Willis

**Workgroup/Committee:**

- same as Champions

**Objectives:** Develop community orchards and gardens at Boot Hill starting in April, 2023, and maintain as long community interest drives the endeavor.

Actions	Person(s) Responsible	Target Date	Status/Notes	Completed Date
1. Identify resources available (people, organizations)	Dahl, Rico Chavez, Willis	Spring, 2022	<ol style="list-style-type: none"> <li>City employees, including Nick Pacha, Nick Duvall, and JJ Bell</li> <li>Other organizations including Washington Master Gardeners and Washington Tree Committee</li> <li>Halcyon House Gardens--Chris Marshall</li> <li>James (Jim) K. Cushing, Community Health Manager; Wellmark Blue Cross and Blue Shield (Des Moines)</li> <li>City Council Presentation, 1/17/23</li> </ol>	Fall, 2022
2. Form a planning committee	Kerrie Willis		<ol style="list-style-type: none"> <li>Original committee included Dahl, Rico Chavez, and Willis.</li> <li>We expanded to include two WHS teachers in Fall, 2022--Davis and Dawson.</li> </ol>	Spring, 2022
3. Conduct initial site planning <ul style="list-style-type: none"> <li>Ensure proper water source is available</li> <li>Test soil to ensure optimal growth of produce</li> </ul>	Andy Dahl		<ol style="list-style-type: none"> <li>Create drawing/rendering of potential site appearance: <a href="#">Andy's Plot Sketch March 2023.pdf</a></li> <li>Water is available at the site. At our last meeting, Council mentioned they could probably cover water cost.</li> <li>Buckets only at this time</li> </ol>	February, 2023
4. Develop infrastructure for garden <ul style="list-style-type: none"> <li>Plot sizes</li> <li>Garden rules</li> </ul>			<ol style="list-style-type: none"> <li>Plot Details <ol style="list-style-type: none"> <li>Plots on flat section</li> <li>Ten feet in between for mowing</li> <li>City land (7 acres)</li> </ol> </li> </ol>	

[Type here]

<ul style="list-style-type: none"> <li>Application process</li> <li>Fee structure</li> <li>Tool shed and tools</li> </ul>			<ul style="list-style-type: none"> <li>d. Expand orchard?</li> <li>e. Choice of 10X10 (\$20) or 10X20 (\$40)</li> <li>f. Farm hydrant = \$100</li> <li>g. City has tentatively offered water at no cost.</li> <li>h. Ask the city for 15' x 30' section for parking on the east side where the curb cutout is, and gravel it.</li> <li>2. Garden Rules             <ul style="list-style-type: none"> <li>a. PENDING (contract to use with people who have a plot on the community garden and/or a liability waiver associated)</li> </ul> </li> <li>3. Application Process             <ul style="list-style-type: none"> <li>a. PENDING (outline of the process for someone to rent a plot)</li> </ul> </li> <li>4. Fee Structure             <ul style="list-style-type: none"> <li>a. PENDING</li> </ul> </li> <li>5. Tool Shed and Tools             <ul style="list-style-type: none"> <li>a. PENDING</li> </ul> </li> </ul>	
5. Build budget			Utilize items listed in #4 for guidance	
6. Development measurement plan			Number of gardeners, pounds of produce, number of volunteers	
7. Create fundraising plan			Grants, private donors – funding, materials, in-kind labor	
8. Develop operational plan for ongoing support			Committee, volunteers, workdays	
9. Develop community engagement strategy for promoting community garden	Committee; Kerrie		<ol style="list-style-type: none"> <li>Interviews and Publications             <ol style="list-style-type: none"> <li>1/25/23 Story in Union: <a href="#">Washington group plans community garden effort   Southeast Iowa Union</a></li> <li>3/23 Interview with KCI</li> </ol> </li> <li>Volunteers / Growing Our Group             <ol style="list-style-type: none"> <li><a href="#">PLANT Washington Padlet</a></li> <li>Add volunteers to the page: Wash Community Orchard and Garden Volunteer Contact Information</li> <li>Create facebook page.</li> <li>Invite volunteers to page.</li> <li>Create garden-specific e-mail.</li> <li>Create a way for people to express interest, join, volunteer, etc.</li> </ol> </li> </ol>	March-April, 2023
10. Hold kickoff event to celebrate opening of the garden		April, 2023	<ul style="list-style-type: none"> <li>Golden Shovel Ceremony</li> </ul>	

**Introduction**

PLANT Washington is the governing authority at the Washington Community Gardens and Orchard located at Boot Hill in Washington, Iowa.

Non-compliance with the rules, terms, and conditions is cause for exclusion from the garden and loss of your plot.

1. If your plot becomes unkempt, you will receive one written or verbal warning from the garden coordinator.
2. If no response or correction has been made in two weeks, your plot will be reassigned or tilled in.
3. You will be allowed to reapply for another garden plot only after one year, and only at the discretion of the garden coordinator.

**Rules, Terms, and Conditions for Participation**

As a member of the Washington Community Gardens and Orchard, I agree to abide by the following rules, terms, and conditions:

1. I use this garden at the sole discretion of PLANT Washington. I agree to abide by its policies and practices.
2. The fee for the use of the garden is (\$20.00 or \$40.00) per plot, per year (January 1 – December 31), due on or before (January 1). There are no refunds.
3. Once I have been assigned a plot, my plot cannot be left fallow or unused for any period of three weeks or longer, more than one time a year.
4. My plot is number (insert plot number) and is (10 x 10 or 10 x 20 ) feet. I will not expand my plot beyond this measurement or into paths or other plots. I will keep all my plants within the limits of my garden plot and will only plant tall crops where they will not shade neighboring plots. I must keep my plot free of weeds, pests and diseases.
5. I will keep my plot, paths, and surrounding areas clean and neat. I will completely separate my trash into three groups: 1) dead plants, leaves, and other green waste plant parts; 2) rocks, stones, and inorganic materials; and 3) paper, plastic, cardboard, wood, metal, and other recyclables. I will put each type of trash only in the areas designated specifically for each. Anything I bring from my home I will take back home. I will not bring household trash and leave it at the Community Gardens

and Orchard.

6. If I must abandon my plot for any reason, I will notify the garden coordinator.
7. I will not apply any pesticides or weed repellants in the garden. I will not use fertilizers that will in any way affect other plots.
8. I will water my plot according to water-wise guidelines.
9. Guests and visitors, including children, may enter the garden only if I accompany them. They must follow all rules, terms, and conditions stated here. I will supervise my children at all times when they are in the garden. I am solely responsible for the behavior of my guests.
10. I will not take food or plants from other gardeners' plots. I will not take anything from the garden that is not rightfully mine.
11. I will respect other gardeners, and I will not use abusive or profane language or discriminate against others.
12. I will work to keep the garden a secure and enjoyable place where all participants can garden and socialize peacefully in a neighborly manner.
13. I agree to volunteer \_\_\_\_\_ hours toward community gardening efforts. (include a list of volunteer tasks which your garden needs).
14. I understand that neither the garden group nor owners of the land are responsible for my actions. I THEREFORE AGREE TO HOLD HARMLESS THE GARDEN GROUP AND OWNERS OF THE LAND FOR ANY LIABILITY , DAMAGE, LOSS OR CLAIM THAT OCCURS IN CONNECTION WITH USE OF THE GARDEN BY ME OR ANY OF MY GUESTS.

### Commitment

I have read and understand the application and accept these rules, terms, and conditions stated above for the participation in the (Garden Name) Community Garden.

Signed: \_\_\_\_\_ Date: \_\_\_\_\_ Gardener

Approved: \_\_\_\_\_ Date: \_\_\_\_\_ Garden  
Manager



Development Services  
215 E. Washington St.  
Washington, IA 52353  
319.653.6584 ext. 124

# Memo

To: City Council  
From: Jeff Duwa-Building and Zoning Official  
Date: 5/9/2023  
Re: Final Plat for Wiley Subdivision Fourth Addition

---

## **Issue**

Review and consider the Final Plat for Wiley Subdivision Fourth Addition.

## **Background**

David Robbs would like to purchase Lot 1 behind the Pizza Ranch. The intent is to build a 40'x 90' warehouse building to store and sell items out of. On Tuesday, May 9, 2023, the City of Washington's Planning and Zoning Commission met to review and discuss the Final Plat for Wiley Subdivision Fourth Addition.

## **Recommendation**

The City of Washington's Planning and Zoning Commission recommends that the City of Washington's City Council approve the Final Plat for Wiley Subdivision Fourth Addition.

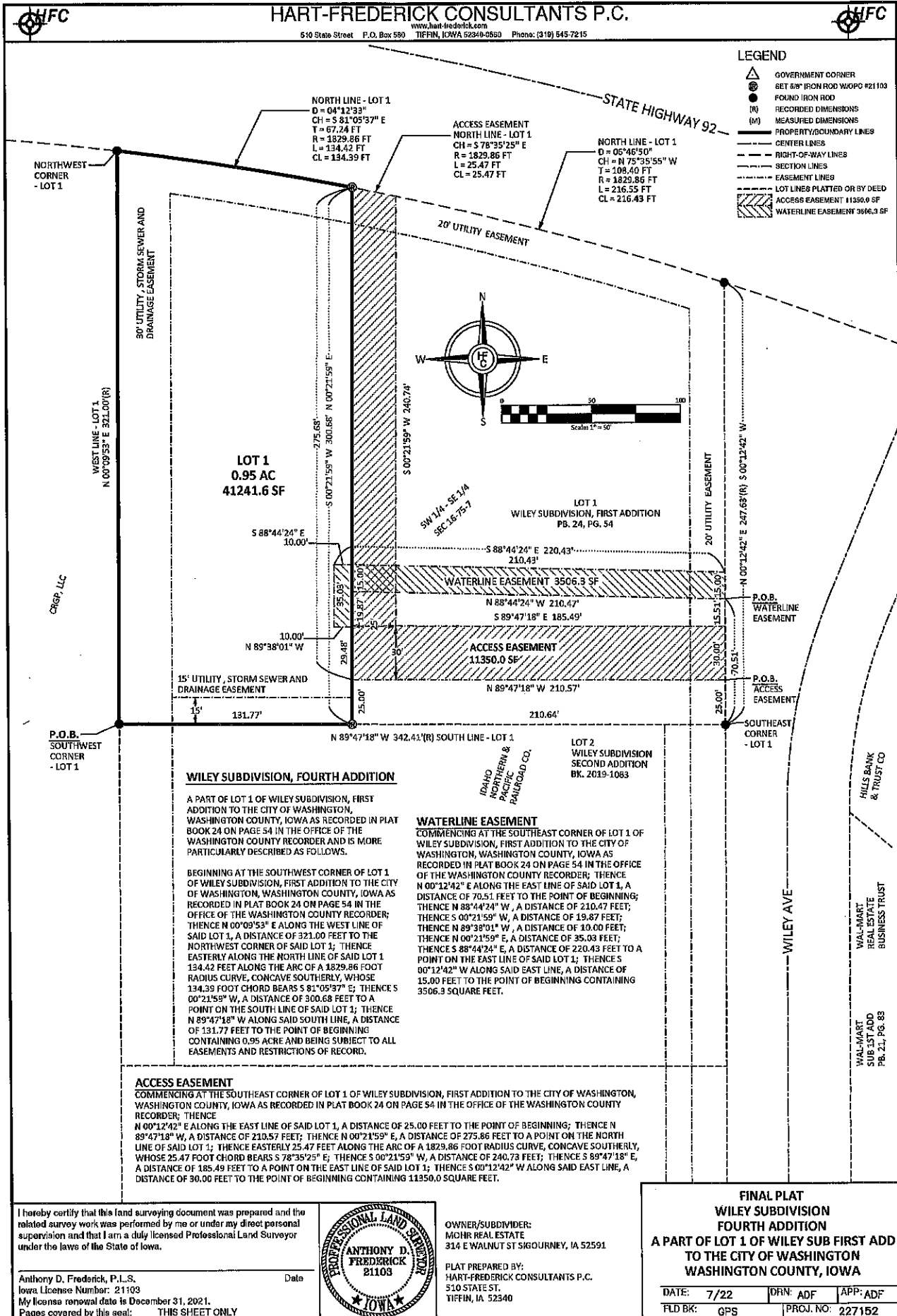

**RESOLUTION 2023-\_\_\_**

**A RESOLUTION APPROVING THE FINAL PLAT FOR  
WILEY SUBDIVISION FOURTH ADDITION,  
WASHINGTON, IOWA**

WHEREAS, the owner did properly file a Final Plat for the Wiley Subdivision Fourth Addition, Washington, Iowa and,

WHEREAS, the legal description for said Subdivision is described as Fourth Addition, A Part of Lot 1 of Wiley Sub First Add to the City of Washington, Washington County, Iowa; and

WHEREAS, the final plat was reviewed and approved by the City of Washington's Planning and Zoning Commission on May 9, 2023; and

WHEREAS, said property has been dedicated with the free consent and in accordance with the desires of the owner; and

WHEREAS, the aforementioned plat and subdivision is found to conform with Chapter 354 of the State Code of Iowa, Chapter 166 of the Washington Code of Ordinances, and all other ordinances and City Staff have been made; and

WHEREAS, after due deliberation, said Commission has recommended that the final platting of the proposed subdivision, be accepted and approved.

NOW, THEREFORE, BE IT RESOLVED, by the City Council of the City of Washington, Iowa, that the final platting of Wiley Subdivision Fourth Addition, Washington, Iowa is hereby approved.

BE IT FURTHER RESOLVED that the City Clerk of the City of Washington, Iowa, is hereby authorized and directed to certify a copy of this Resolution to the County Recorder of Washington County, Iowa.

PASSED AND APPROVED this 16th day of May, 2023.

\_\_\_\_\_  
Millie Youngquist, Mayor Pro Tem

ATTEST:

\_\_\_\_\_  
Sally Y. Hart, City Clerk

*Millie Youngquist, Mayor Pro Tem  
Sally Hart, City Clerk  
Kevin Olson, City Attorney  
Deanna McCusker, City Administrator*



*City of Washington  
215 East Washington Street  
Washington, Iowa 52353  
(319) 653-6584 Phone  
(319) 653-5273 Fax*

---

May 12, 2023

To: Mayor & City Council  
Cc: Sally Hart, City Clerk & Kelsey Brown, Finance Director

From: Deanna McCusker  
City Administrator

Re: Alley

The alley to the south of the Marion Avenue Baptist gym is in disrepair. This alley is located between S Ave B and South Marion between S Jefferson and W Washington. There have been conversations with Marion Avenue concerning this and since they did contribute to the negative affects in the alley, they are willing to contribute 33% of the cost of the alley repair.

With 2 quotes received, Coleman Construction being the low bidder at \$24,272.50, Marion Avenue Baptist will contribute \$8009 for the project.

Thank you.



**RESOLUTION NO. 2023-\_\_**

**A RESOLUTION APPROVING THE QUOTE FOR THE ALLEY PROJECT**

WHEREAS, two quotes were received for the alley repair project located between S B Ave & S Marion Ave between W Jefferson and W. Washington.

NOW, THEREFORE, BE IT RESOLVED BY THE CITY COUNCIL OF THE CITY OF WASHINGTON, IOWA:

Section 1. That the following quote for the construction of certain public improvements be and is hereby accepted, the same being the lowest responsible quote received for said work, as follows:

Contractor: Coleman Construction, Inc.

Amount of Bid: \$24,272.50

PASSED AND APPROVED, this 16<sup>th</sup> day of May, 2023.

\_\_\_\_\_  
Millie Youngquist, Mayor Pro Tem

ATTEST:

\_\_\_\_\_  
Sally Y. Hart, City Clerk

## Sally Hart

---

**From:** JJ Bell <jjbell@washingtioniowa.gov>  
**Sent:** Monday, April 24, 2023 3:21 PM  
**To:** Deanna McCusker; Sally Hart  
**Subject:** Alley Quote by Marion Ave Church

Coleman quote for 2,555 sq ft @ \$9.50 comes to \$24,272.50  
I am working on another quote from Bruty Construction.  
The church is willing to pay \$10,000 if the City pays the rest.  
I would like this to go to Council obviously. either May 2 or more than likely May 16.  
I will let you know what Bruty comes back with, thanks

--  
J J Bell  
Superintendent  
City of Washington  
Maintenance & Construction Dept  
515 East 6th St  
Washington, IA, 52353  
[jjbell@washingtioniowa.gov](mailto:jjbell@washingtioniowa.gov)  
Cell:319-653-1538

# BID/ESTIMATE

Gr  
70  
W:

Greg Bruty Construction, LLC

701 East 14<sup>th</sup> Street

Washington, IA 52353

319-461-4808

[greg.bruty@gmail.com](mailto:greg.bruty@gmail.com)

**DATE: APRIL 27, 2023**

**BID/ESTIMATE TO:**  
City of Washington  
Attn: J. J. Bell

**JOB SITE:**  
Alley at Marion Avenue Church

DESCRIPTION	AMOUNT
Remove & replace the alley at Marion Avenue Church	
2,555 sq. ft. @ \$9.75/sq. ft.	
<b>TOTAL BID/ESTIMATE</b>	<b>\$24,911.00</b>

**Thank you for the opportunity to bid on your job!**

**RESOLUTION NO. 2023-**

**A RESOLUTION AMENDING CERTAIN CHARGES AND FEES FOR THE ELM GROVE AND WOODLAWN CEMETERIES**

**WHEREAS**, City Council updated certain charges and fees for the Elm Grove and Woodlawn Cemeteries in November, 2022, but with different leadership some changes are updated changes are recommended.

**WHEREAS**, Section 115.09 of the Municipal Code of the City of Washington, Iowa, provides that the City Council may adopt by Resolution rules and regulations, including fees for services with regards to the City's cemeteries.

**NOW, THEREFORE, BE IT RESOLVED BY THE CITY COUNCIL OF THE CITY OF WASHINGTON, IOWA**, that the City Council hereby:

1. Authorizes the sale price of six hundred dollars (\$600) per columbarium.
2. Authorizes, at the discretion of the Cemetery Sexton, an additional charge of a one hundred dollar (\$100) fee in addition to the fee for regular weekday/weekend interments when there is inclement weather.

**PASSED AND APPROVED** this 16<sup>th</sup> day of May, 2023.

\_\_\_\_\_  
Millie Youngquist, Mayor Pro Tem

ATTEST:

\_\_\_\_\_  
Sally Y. Hart, City Clerk

*Millie Youngquist, Mayor Pro Tem  
Sally Hart, City Clerk  
Kevin Olson, City Attorney  
Deanna McCusker, City Administrator*



**City of Washington**  
*215 East Washington Street  
Washington, Iowa 52353  
(319) 653-6584 Phone  
(319) 653-5273 Fax*

---

May 4, 2023

To: Mayor & City Council

Cc: Sally Hart, City Clerk, Kelsey Brown, Finance Director, Zach Wibstad, Cemetery Sexton

From: Deanna McCusker  
City Administrator

Re: Amended cemetery fees

We are making a couple slight changes to the fees at the cemetery with new leadership. The price for all the spaces at the columbarium will be \$600 no matter the placement. Additionally, there will be a \$100 fee that is up to the discretion of the sexton regarding inclement weather. There can be inclement weather at any time of the year that causes additional work to prepare for a funeral.

I would recommend that these amended fees be approved.

Thank you for your consideration.

*Millie Youngquist, Mayor Pro Tem  
Sally Hart, City Clerk  
Kevin Olson, City Attorney  
Deanna McCusker, City Administrator*



*City of Washington  
215 East Washington Street  
Washington, Iowa 52353  
(319) 653-6584 Phone  
(319) 653-5273 Fax*

---

May 12, 2023

To: Mayor & City Council  
Cc: Sally Hart, City Clerk & Kelsey Brown, Finance Director

From: Deanna McCusker  
City Administrator

Re: Tax Abatement Program

Attached is the memo from March 26, 2012 when the City of Washington began the tax abatement program. It states that it was started to provide partial tax exemptions for new construction and/or major renovation projects. From the spreadsheet attached it indicates that 87% of those approved have been for new construction.

This program was then approved to continue for another 3 years in December 2022.

# THE CITY OF WASHINGTON

*"Cleanest City in Iowa"*

Sandra Johnson, Mayor  
Brent Hinson, City Administrator  
Illa Earnest, City Clerk  
Craig Arbuckle, City Attorney

215 E. Washington St.  
Washington, IA 52353

319-653-6584  
Fax Only 319-653-5273

## Memorandum

March 26, 2012

To: Mayor & City Council  
Cc: Illa Earnest, City Clerk

FROM: Brent Hinson  
City Administrator



Re: Tax Abatement

From 1992 until early 2009, the City of Washington had some form of tax abatement program for residential, commercial and/or industrial properties. I would like the Council to consider re-enacting the program to stimulate future growth and development within Washington's city limits.

A tax abatement program is generally described as the offering of partial tax exemptions for new construction and/or major renovation of eligible properties. Most cities I'm familiar with include the entire city limits in their plan, as was done in Washington's 2005 Urban Revitalization Plan. The State of Iowa allows a partial exemption for certain industrial properties, and this section has been used separately on several occasions, including ACH Foam's recent expansion. I believe what has been done in the past has been a bit of a mishmash that was unnecessarily confusing to all involved. Therefore, I'd like to start fresh by updating the City's Urban Revitalization Plan according to the guidelines laid out in Chapter 404 of the Iowa Code.

The Iowa Code sets the following maximum limits for tax exemptions: 10 year schedule, starting at 80% exemption and sliding to 20% in Year 10 (see attached table for more detail) or 100% exemption for the first 3 years. For residential properties, a city may offer an exemption of up to 100% for five years on the first \$75,000 of value added.

The reasons for enacting a tax abatement program are many, in my opinion. Tax abatement is by its nature an incentive to improve one's property or to construct new improvements. In the residential context, the existence of a tax abatement program may mean the difference between a home being constructed in the city limits of Washington or an outlying subdivision, or even another community. It can help reduce the cost of a new or majorly renovated home in the first few years, which is often very helpful for young

families of the sort we want to continue to attract to Washington. In the commercial/industrial context, the increased operating costs of a new or expanded operation may be partially offset for the first few years by the tax exemption.

It is always difficult to say whether or not a given development would have occurred "if not for the incentives". However, I believe, as I have said in the past, that we should consider what we can do to be development-friendly, whether it is in processes or in incentives. Offering tax abatement is a way to be friendly to smaller and especially infill developments, whereas I would plan to develop a written TIF incentives plan to cover the larger projects and new subdivisions. In the end, a well-structured tax abatement program is easier & cheaper to administer than TIF for smaller developments. Finally, I believe that the best way reduce the tax rate over time while continuing to provide excellent services is to continually work to expand the tax base. In the scenario I propose, the City would give up a portion of the taxes for the first few years of a new development, but of course would collect full taxes every year beyond that. If we only incentivize a small amount of development that would not happen otherwise, we will be money ahead in the long term.

To achieve the full impact of tax abatement, it needs to be perceived as an on-going program rather than just short-term. In the past, Washington renewed its plan for just 3 years at a time. I believe a much better plan would be 10 years at a time, as it provides more certainty to a business possibly looking to expand in the future or a resident planning to build a new house or majorly renovate their existing house. The planning horizon for business expansion or even new home construction or renovation often extends beyond 3 years as it is. My perception is that this has created a sense of unfairness with the past program from some who had hoped to utilize the program but then found they were just outside the dates of eligibility after the plan expired.

Please see the attached table for my proposal, which I think is much easier to read and understand in that format rather than written-out.

Brent



<b>Tax Abatement Program</b>			
<u>Date approved</u>	<u>Address</u>	<u>Type</u>	
12/6/2022	1134 W. Buchanan	Vacant, Commercial	New Construction
10/18/2022	1628-1630 Highland Ave.	Residential	New Construction
9/20/2022	504 S. 15th Avenue	Residential	New Construction
3/1/2022	505 West 5th Street	Residential	New Construction
2/15/2022	Bazooka Farmstar	Industrial	Addition
1/19/2022	1405 N. 4th Avenue	Residential	New Construction
1/19/2022	1026 E. Adams St.	Residential	General Improvements
7/7/2020	610 S. 10th Avenue	Residential	New Construction
7/7/2020	1622 Highland Avenue	Residential	New Construction
7/7/2020	1624 Highland Avenue	Residential	New Construction
7/7/2020	1013 E. Adams Street	Residential	New Construction
7/7/2020	1015 E. Adams Street	Residential	New Construction
4/7/2020	415 West Madison St.	Residential	New Construction
2/18/2020	1127 E. Adams St.	Residential	New Construction
12/17/2019	1122 E. 3rd St.	Residential	New Construction
12/3/2019	1580 W. 5th St.	Residential	New Construction
11/5/2019	1701 E. Washington St.	Commercial	General Improvements
11/5/2019	120 W. 3rd St.	Residential	New Construction
9/3/2019	1410 E. 3rd St.	Commercial	New Construction
6/18/2019	122 W. 3rd St.	Residential	New Construction
6/4/2019	107 W. 15th St.	Residential	New Construction
6/4/2019	116 W. 3rd St.	Residential	New Construction
6/4/2019	1636 Highland Ave.	Residential	New Construction
6/4/2019	124 W. 3rd St.	Residential	New Construction
6/4/2019	118 W. 3rd St.	Residential	New Construction
11/21/2017	107 S. Marion Ave.	Commercial/Residential	General Improvements
5/16/2017	301 E. 5th St.	Commercial	New Construction
2/7/2017	1307 N. 2nd Avenue	Residential	New Construction
12/6/2016	702 E. 14th Street	Vacant, Commercial	New Construction
11/3/2015	Jeffrey Brock		
5/20/2014	Andrew Drahota		
11/6/2013	1415 West 5th St.	Commercial	New Construction
8/21/2013	834 S. 9th Avenue	Residential	New Construction
8/7/2013	110 West Main Street	Vacant, Residential	New Construction
8/7/2013	1010 W. Madison St.	Commercial	General Improvements
2012	475 W. 18th St.	Residential	New Construction
2012	465 W. 18th St.	Residential	New Construction
	<b>TOTALS:</b>		
	<b>General Improvements - 4</b>		
	<b>New Construction - 30</b>		

**RESOLUTION NO. 2022-124**

**A RESOLUTION EXTENDING TAX ABATEMENT PROGRAM  
UNDER THE WASHINGTON URBAN REVITALIZATION PLAN  
FOR WASHINGTON, IOWA**

WHEREAS, the City of Washington, Iowa, has a property tax exemption program for improvements under the provisions of the Washington Urban Revitalization Plan adopted by the City Council of the City of Washington, Iowa; and

WHEREAS, the program is scheduled to end December 31<sup>st</sup>, 2022, and the City Council wishes to extend the program for an additional three years with a new expiration date of December 31<sup>st</sup>, 2025.

WHEREAS, all qualified real estate assessed as residential property is eligible to receive a one hundred percent exemption from taxation on the first seventy-five thousand dollars of actual value added by the improvements with the exemption for a period of three years, and improvements must increase the assessed value by a minimum of ten percent; and

WHEREAS, all qualified real estate assessed as commercial and/or industrial property is eligible to receive a partial exemption from taxation on the actual value added by the improvements, the exemption is for a period of five years, improvements must increase the assessed value by a minimum of ten percent; and the partial exemption is equal to a percent of the actual value added by the improvements as follows: First Year – seventy-five percent exemption, Second Year – sixty percent exemption, Third Year – forty-five percent exemption, Fourth Year – thirty percent exemption, Fifth Year – fifteen percent exemption; and

WHEREAS, future applications shall have a deadline of December 31<sup>st</sup>, 2025 for submission and consideration.

NOW, THEREFORE, BE IT RESOLVED BY THE COUNCIL OF THE CITY OF WASHINGTON, IOWA, has extended the Tax Abatement Program Under the Washington Urban Revitalization Plan for the City of Washington, Iowa;

BE IT FUTHER RESOLVED that the City Clerk be instructed to submit this resolution to the Washington County Assessor.

Passed and approved this 15<sup>th</sup> day of November, 2022.

  
\_\_\_\_\_  
Jaron Rosien, Mayor

Attest:

  
\_\_\_\_\_  
Sally Y. Hart, City Clerk

**RESOLUTION NO. 2023-\_\_**

**A RESOLUTION AUTHORIZING TAX ABATEMENT  
UNDER THE WASHINGTON URBAN REVITALIZATION PLAN  
FOR WASHINGTON, IOWA**

WHEREAS, the City of Washington, Iowa, has a property tax exemption for improvements under the provisions of the Washington Urban Revitalization Plan adopted by the City Council of the City of Washington, Iowa; and

WHEREAS, all qualified real estate assessed as residential property is eligible to receive a one hundred percent exemption from taxation on the first seventy-five thousand dollars of actual value added by the improvements with the exemption for a period of three years; and

WHEREAS, improvements must increase the assessed value by a minimum of ten percent; and

WHEREAS, the attached application for 501 South 15<sup>th</sup> Avenue, Washington, a residence owned by Daniel P. and Nicole A. Kitchen, Parcel ID 1116359006, Lot 6, Prairie Ridge Subdivision, has been completed and reviewed by staff and is recommended for approval.

NOW, THEREFORE, BE IT RESOLVED BY THE COUNCIL OF THE CITY OF WASHINGTON, IOWA that the City Clerk be instructed to certify the attached application and submit it to the Washington County Assessor.

Passed and Approved this 16th day of May, 2023.

\_\_\_\_\_  
Millie Youngquist, Mayor Pro Tem

Attest:

\_\_\_\_\_  
Sally Y. Hart, City Clerk

APPLICATION FOR TAX ABATEMENT UNDER THE  
WASHINGTON URBAN REVITALIZATION PLAN FOR  
WASHINGTON, IOWA

Prior Approval for Intended Improvements

Approval of Improvements Completed

FOR PROPERTY TAX EXEMPTION FOR IMPROVEMENTS UNDER THE PROVISIONS OF THE WASHINGTON URBAN REVITALIZATION PLAN ADOPTED BY THE CITY COUNCIL OF THE CITY OF WASHINGTON, IOWA

The Washington Urban Revitalization Plan allows property tax exemptions as follows:

Residential

All qualified real estate assessed as residential property is eligible to receive a one hundred percent (100%) exemption from taxation on the first seventy-five thousand dollars (\$75,000) of actual value added by the improvements. The exemption is for a period of three (3) years. Improvements must increase the assessed value by a minimum of 10%.

Commercial/Industrial

All qualified real estate assessed as commercial and/or industrial property is eligible to receive a partial exemption from taxation on the actual value added by the improvements. The exemption is for a period of five (5) years. Improvements must increase the assessed value by a minimum of 10%. The amount of the partial exemption is equal to a percent of the actual value added by the improvements, determined as follows:

- 1) First Year – 75% Exemption
- 2) Second year – 60% Exemption
- 3) Third Year – 45% Exemption
- 4) Fourth Year – 30% Exemption
- 5) Fifth Year – 15% Exemption

Commercial includes property that consists of 3 or more separate living quarters with at least 75% of the space used for residential purposes.

In order to be eligible, the property must be located in the Washington Revitalization Area. A map is available for inspection at City Hall.

This application must be filed with the City by February 1 of the assessment year for which the exemption is first claimed, but not later than 2 years after the February 1<sup>st</sup> following the year that the improvements are first assessed for taxation.

Address of Property: 501 South 15<sup>th</sup> Avenue

Legal Description: Lot 6, Prairie Ridge Subdivision

Title Holder or Contract Buyer: Daniel P. and Nicole A. Kitchen

Address of Owner (if different than above): \_\_\_\_\_

Phone Number (to be reached during the day): 319 541 2567

Is there a Tenant on the Property that will be displaced by the Improvements who has occupied the same dwelling unit continuously for 1 year prior to \_\_\_\_\_ [insert date of adoption of the Plan]? Yes \_\_\_ No \_\_\_

Existing Property Use: \_\_\_ Residential \_\_\_ Commercial \_\_\_ Industrial  Vacant

Proposed Property Use: Residential

Nature of Improvements:  New Construction \_\_\_ Addition \_\_\_ General Improvements

Specify: New home

Permit Number(s) from the City of 220272 Building Department

Date Permit(s) Issued: 8/22/2022

Permit(s) Valuation: \_\_\_\_\_ [Attach approved Building Permit to this application]

Estimated or Actual Date of Completion: 4-10-2023

Nature of Improvements:  New Construction  Addition  General Improvements

Specify: House

Permit Number(s) from the City of \_\_\_\_\_ Building Department

Date Permit(s) Issued: \_\_\_\_\_

Permit(s) Valuation: \_\_\_\_\_

[Attach approved Building Permit to this application]

Estimated or Actual Date of Completion: April 2023

Estimated or Actual Cost of Improvements: ~\$432,000

Signature: 

Name (Printed) Daniel P. Kitchen

Title: Owner

Company: N/A

Date: 4-24-23

FOR CITY USE

CITY COUNCIL	Application Approved/Disapproved _____
	Reason (if disapproved) _____
	Date _____ Resolution No. _____
	Attested by the City Clerk _____
ASSESSOR	Present Assessed Value of Structure _____
	Assessed Value with Improvements _____
	Eligible or Noneligible for Tax Abatement _____
	Assessor _____ Date _____

\* Example: To receive a full 5 year exemption on Improvements that were first fully assessed on 1-1-2012, the property owner must file the application with the City no later than 2-1-2014.

This Application is a summary of some of the Plan terms; for complete information, read a copy of the WASHINGTON URBAN REVITALIZATION PLAN, available at City Hall.

The program ends December 31, 2025. Applications must be submitted by December 31, 2025.

**ATTACHMENTS: ATTACH YOUR APPROVED BUILDING PERMIT TO THIS APPLICATION**

**This Application is to be forwarded by the City to the County Assessor by March 1.**

*Jaron P. Rosien, Mayor  
 Sally Hart, City Clerk  
 Kevin Olson, City Attorney  
 Deanna McCusker, City  
 Administrator*



**City of Washington**  
 215 East Washington Street  
 Washington, Iowa 52353  
 (319) 653-6584 Phone  
 (319) 653-5273 Fax

## Residential Building Permit

**Permit Number:** 220272  
**Property Address:** 501 S 15th Ave

**Project Cost:** 284000  
**Issue Date:** 08/22/2022  
**Expiration Date:** 02/18/2023

**Job Description:** New single family home

**Owner:**  
 SAK Development Inc  
 622 S 15th Ave  
 Washington, IA 52353  
 3194612044  
 vcinc2044@gmail.com

**Contractor:**  
 Vogel Construction  
 1430 Ridgeview Ct.  
 Washington, IA 52353

Fees	Amount	Payments	Account Paid
Building Zoning Permit Fee	\$1,315.70	VC Inc	\$1,315.70
<b>Total Fee: \$1,315.70</b>		<b>Total Paid: \$1,315.70</b>	

**Notes:**

\_\_\_\_\_  
 Issued By Jeff Duwa

\_\_\_\_\_  
 08/23/2022  
 Date

**RESOLUTION NO. 2023-\_\_\_\_\_**

**A RESOLUTION APPROVING A TEMPORARY MAYOR PRO TEM APPOINTMENT  
FOR THE CITY OF WASHINGTON**

WHEREAS, Millie Youngquist is the Mayor Pro Tem and performing the duties of the Mayor since February 2023; and,

WHEREAS, since there are circumstances that may prevent the Mayor Pro Tem from attending a meeting, it is necessary to appoint a temporary Mayor Pro Tem in her absence; and,

WHEREAS, Illa Earnest has agreed to act as Mayor Pro Tem in the event the presiding Mayor Pro Tem Youngquist is unable to attend a meeting.

NOW, THEREFORE, BE IT RESOLVED BY THE CITY COUNCIL OF THE CITY OF WASHINGTON, IOWA:

Section 1. The City Council hereby approves the appointment of Illa Earnest as temporary Mayor Pro Tem in the absence of the presiding Mayor Pro Tem Youngquist.

Section 2. All Resolutions or parts of Resolutions in conflict herewith are hereby repealed to the extent of such conflict.

PASSED AND APPROVED this 16<sup>th</sup> day of May, 2023.

\_\_\_\_\_  
Millie Youngquist, Mayor Pro Tem

ATTEST:

\_\_\_\_\_  
Sally Y. Hart, City Clerk

RESOLUTION NO. 2023-

A RESOLUTION ADOPTING A CODE OF ETHICS FOR ELECTED OFFICIALS

WHEREAS, it is has been identified that a code of ethics for elected officials should be developed; and,

WHEREAS, a proposed code of ethics has been developed based on review of sample codes; and,

WHEREAS, the City Council will review and adopt if acceptable.

NOW, THEREFORE, BE IT RESOLVED BY THE CITY COUNCIL OF THE CITY OF WASHINGTON, IOWA:

Section 1. The attached Code of Ethics are hereby adopted.

Section 2. Councilors agree to abide by this code as written.

Section 3. All Resolutions or parts of Resolutions in conflict herewith are hereby repealed, to the extent of such conflict.

PASSED AND APPROVED this 16<sup>th</sup> day of May, 2023.

---

Millie Youngquist, Mayor Pro Tem

ATTEST:

---

Sally Y. Hart, City Clerk



## **CODE OF ETHICS FOR ELECTED OFFICIALS**

### **CITY OF WASHINGTON IOWA**

#### *Statement of Commitment*

Each elected official shall conduct themselves with the highest standard of ethics and conduct themselves to the best of their abilities, skills, efforts and have the best interest of the City of Washington, their staff and residents in mind with every action.

#### *Elected Officials Standards*

The City of Washington elected officials shall hold each member to the highest standards of ethical, professional behavior.

- To understand the role of the council as a policy-making body.
- To learn and consistently to use designated channels when conducting city business.
- To refrain from actions and involvement that might prove embarrassing to the City of Washington and to resign if such actions or involvement develop.
- To make judgments always based on what is best for the organization as a whole.

#### *Representing the City of Washington*

As an elected official, each member will represent the organization informally and formally to other associations, government officials, and business representatives. Each member will represent the City in such a way as to leave others with a positive impression of the organization. Each member will preserve and enhance the good reputation of the City and will avoid behavior which might damage its image.

#### *Delegation and Penalties*

Penalties imposed for breach of the code of ethics may include, but not limited to the following:

- Removal of the elected official from office by a resolution passed by a vote of two-thirds of the city council, provided that notice of such a proposed resolution is given with the notice calling the meeting.

**RESOLUTION NO. 2023-\_\_\_\_\_**

**RESOLUTION APPROVING A MOWING MAINTENANCE AGREEMENT WITH  
WCHS FOR MOWING SERVICES FOR LOT 7**

WHEREAS, the WCHS recently purchased Lot 7 in the Southwest Business Park; and,

WHEREAS, until WCHS begins construction on the lot for their new animal shelter, the City of Washington will mow the property; and,

WHEREAS, the fee for providing the mowing services will be \$125 per time the property is mowed.

NOW, THEREFORE, BE IT RESOLVED BY THE CITY COUNCIL OF THE CITY OF WASHINGTON, IOWA:

Section 1. That the City Council hereby approves the Mowing Maintenance Agreement with WCHS as attached to this Resolution.

Section 2. All Resolutions or parts of Resolutions in conflict herewith are hereby repealed to the extent of such conflict.

PASSED AND APPROVED this 16<sup>th</sup> day of May, 2023.

\_\_\_\_\_  
Millie Youngquist, Mayor Pro Tem

ATTEST:

\_\_\_\_\_  
Sally Y. Hart, City Clerk

MOWING MAINTENANCE AGREEMENT

THIS AGREEMENT (the "Agreement") entered into by and between the City of Washington, Iowa (the "City") and the Washington County Humane Society ("WCHS").

WHEREAS, WCHS purchased Lot 7, Washington Business Park Subdivision, Phase One, from the City (the "Property"); and

WHEREAS, WCHS is currently fundraising to build a new facility to house Paws and More Shelter on the Property; and

WHEREAS, the City uses WCHS for animal control services; and

WHEREAS, WCHS has inquired about whether it can mow the Property until such time as it constructs its facility on the Property.

NOW, THEREFORE, the parties agree as follows:

1. That until the time of termination of this Agreement, the City shall mow the Property at such times as it deems necessary to comply with applicable ordinances.
2. That WCHS shall, within 30 days of invoice from the City, pay the City the sum of \$125 for each time that the City mows the Property.
3. In the event that WCHS fails to pay the cost of said mowing, WCHS specifically agrees that the City can certify said costs to the Washington County Treasurer for collection as property taxes and that WCHS waives all notice, benefit and limitation requirements of special assessments against a property.
4. This Agreement shall remain in full force and effect unless notice of termination is delivered by either party in writing to the other party with thirty (30) days notice.

WCHS:

CITY:

\_\_\_\_\_

\_\_\_\_\_

Millie Younquist, Mayor Pro tem

\_\_\_\_\_  
Print name and title

## ITEM TO INCLUDE ON AGENDA

### CITY OF WASHINGTON, IOWA

May 16, 2023

6:00 P.M.

#### Washington East Commercial Urban Renewal Plan

- Resolution determining the necessity and setting dates of a consultation and a public hearing on a proposed Washington East Commercial Urban Renewal Plan for a proposed Urban Renewal Area in the City of Washington, State of Iowa.

#### IMPORTANT INFORMATION

1. The above agenda items should be included, along with any other agenda items, in the meeting agenda. The agenda should be posted on a bulletin board or other prominent place easily accessible to the public and clearly designated for that purpose at the principal office of the body holding the meeting. If no such office exists, the notice must be posted at the building in which the meeting is to be held.
2. If you do not now have a bulletin board designated as above mentioned, designate one and establish a uniform policy of posting your notices of meeting and tentative agenda.
3. Notice and tentative agenda must be posted at least 24 hours prior to the commencement of the meeting.

NOTICE MUST BE GIVEN PURSUANT TO CHAPTER 21,  
CODE OF IOWA, AND THE LOCAL RULES OF THE CITY.

*Millie Youngquist, Mayor Pro Tem  
Sally Hart, City Clerk  
Kevin Olson, City Attorney  
Deanna McCusker, City Administrator*



*City of Washington  
215 East Washington Street  
Washington, Iowa 52353  
(319) 653-6584 Phone  
(319) 653-5273 Fax*

---

May 12, 2023

To: Mayor & City Council  
Cc: Sally Hart, City Clerk & Kelsey Brown, Finance Director

From: Deanna McCusker  
City Administrator

Re: Setting Public Hearing Dates for the East Commercial Urban Renewal Area

Council is setting dates for a consultation meeting with the County Supervisors for May 25, 2023. Also to set the date of a public hearing on the Urban Renewal for June 20, 2023. Also, included with these proceedings is the need for a P&Z meeting.

These proceedings are just setting dates for the Urban Renewal Area. More proceedings will be coming in the near future.

Thank you.

May 16, 2023

The City Council of the City of Washington, State of Iowa, met in \_\_\_\_\_ session, in the Council Chambers, City Hall, 215 East Washington Street, Washington, Iowa, at 6:00 P.M., on the above date. There were present Mayor \_\_\_\_\_, in the chair, and the following named Council Members:

\_\_\_\_\_

Absent: \_\_\_\_\_

Vacant: \_\_\_\_\_

\*\*\*\*\*

Council Member \_\_\_\_\_ then introduced the following proposed Resolution entitled "RESOLUTION DETERMINING THE NECESSITY AND SETTING DATES OF A CONSULTATION AND A PUBLIC HEARING ON A PROPOSED WASHINGTON EAST COMMERCIAL URBAN RENEWAL PLAN FOR A PROPOSED URBAN RENEWAL AREA IN THE CITY OF WASHINGTON, STATE OF IOWA", and moved that the same be adopted. Council Member \_\_\_\_\_ seconded the motion to adopt. The roll was called, and the vote was:

AYES: \_\_\_\_\_  
\_\_\_\_\_

NAYS: \_\_\_\_\_

Whereupon, the Mayor declared the Resolution duly adopted as follows:

RESOLUTION NO. \_\_\_\_\_

RESOLUTION DETERMINING THE NECESSITY AND SETTING DATES OF A CONSULTATION AND A PUBLIC HEARING ON A PROPOSED WASHINGTON EAST COMMERCIAL URBAN RENEWAL PLAN FOR A PROPOSED URBAN RENEWAL AREA IN THE CITY OF WASHINGTON, STATE OF IOWA

WHEREAS, it is hereby found and determined that one or more economic development areas, as defined in Chapter 403, Code of Iowa, exist within the City and the rehabilitation, conservation, redevelopment, development, or combination thereof, of the area is necessary in the interest of the public health, safety, or welfare of the residents of the City; and

WHEREAS, this Council has caused there to be prepared a proposed Washington East Commercial Urban Renewal Plan ("Plan" or "Urban Renewal Plan") for the Washington East Commercial Urban Renewal Area ("Area" or "Urban Renewal Area"), which proposed Plan is attached hereto as Exhibit 1 and which is incorporated herein by reference; and

WHEREAS, the purpose of the Plan is to form the Washington East Commercial Urban Renewal Area suitable for economic development and to include a list of proposed projects to be undertaken within the Urban Renewal Area, and a copy of the Plan has been placed on file for public inspection in the office of the City Clerk; and

WHEREAS, the property proposed to be included in the Urban Renewal Area is legally described in the Plan and this Council has reasonable cause to believe that the Area described in the Plan satisfies the eligibility criteria for designation as an urban renewal area under Iowa law and; and

WHEREAS, the land proposed to be included in the Area contains property within Washington County, Iowa that is outside, but within two miles, of the corporate limits of the City, and Washington County and the City will execute a Joint Agreement to allow the City to establish the Urban Renewal Area outside the corporate limits of the City and within Washington County; and

WHEREAS, it is desirable that the area be redeveloped as part of the overall redevelopment covered by the Plan; and

WHEREAS, the Iowa statutes require the City Council to submit the proposed Urban Renewal Plan to the Planning and Zoning Commission for review and recommendation as to its conformity with the general plan for development of the City as a whole prior to Council approval of such Plan, and further provides that the Planning and Zoning Commission shall submit its written recommendations thereon to this Council within thirty (30) days of its receipt of such proposed Urban Renewal Plan; and

WHEREAS, the Iowa statutes require the City Council to notify all affected taxing entities of the consideration being given to the proposed Urban Renewal Plan and to hold a consultation with such taxing entities with respect thereto, and further provides that the designated



representative of each affected taxing entity may attend the consultation and make written recommendations for modifications to the proposed division of revenue included as a part thereof, to which the City shall submit written responses as provided in Section 403.5, Code of Iowa, as amended; and

WHEREAS, the Iowa statutes further require the City Council to hold a public hearing on the proposed Urban Renewal Plan subsequent to notice thereof by publication in a newspaper having general circulation within the City, which notice shall describe the time, date, place and purpose of the hearing, shall generally identify the urban renewal area covered by the Plan and shall outline the general scope of the urban renewal project under consideration, with a copy of the notice also being mailed to each affected taxing entity.

NOW THEREFORE, BE IT RESOLVED, BY THE CITY COUNCIL OF THE CITY OF WASHINGTON, STATE OF IOWA:

Section 1. That the consultation on the proposed Urban Renewal Plan required by Section 403.5(2), Code of Iowa, as amended, shall be held on May 25, 2023, in the Council Chambers, City Hall, 215 East Washington Street, Washington, Iowa, at 1:00 P.M., and the City Administrator, or her delegate, is hereby appointed to serve as the designated representative of the City for purposes of conducting the consultation, receiving any recommendations that may be made with respect thereto and responding to the same in accordance with Section 403.5(2), Code of Iowa.

Section 2. That the City Clerk is authorized and directed to cause a notice of such consultation to be sent by regular mail to all affected taxing entities, as defined in Section 403.17(1), Code of Iowa, along with a copy of this Resolution and the proposed Urban Renewal Plan, the notice to be in substantially the following form:

NOTICE OF A CONSULTATION TO BE HELD BETWEEN THE CITY OF WASHINGTON, STATE OF IOWA AND ALL AFFECTED TAXING ENTITIES CONCERNING THE PROPOSED WASHINGTON EAST COMMERCIAL URBAN RENEWAL PLAN FOR THE CITY OF WASHINGTON, STATE OF IOWA

The City of Washington, State of Iowa will hold a consultation with all affected taxing entities, as defined in Section 403.17(1), Code of Iowa, as amended, commencing at 1:00 P.M. on May 25, 2023, in the Council Chambers, City Hall, 215 East Washington Street, Washington, Iowa concerning a proposed Washington East Commercial Urban Renewal Plan for the Washington East Commercial Urban Renewal Area, a copy of which is attached hereto.

Each affected taxing entity may appoint a representative to attend the consultation. The consultation may include a discussion of the estimated growth in valuation of taxable property included in the proposed Urban Renewal Area, the fiscal impact of the division of revenue on the affected taxing entities, the estimated impact on the provision of services by each of the affected taxing entities in the proposed Urban Renewal Area, and the duration of any bond issuance included in the Plan.

The designated representative of any affected taxing entity may make written recommendations for modifications to the proposed division of revenue no later than seven days following the date of the consultation. The City Administrator, or her delegate, as the designated representative of the City of Washington, State of Iowa, shall submit a written response to the affected taxing entity, no later than seven days prior to the public hearing on the proposed Washington East Commercial Urban Renewal Plan, addressing any recommendations made by that entity for modification to the proposed division of revenue.

This notice is given by order of the City Council of the City of Washington, State of Iowa, as provided by Section 403.5, Code of Iowa, as amended.

Dated this \_\_\_\_\_ day of \_\_\_\_\_, 2023.

\_\_\_\_\_  
City Clerk, City of Washington, State of Iowa

(End of Notice)

Section 3. That a public hearing shall be held on the proposed Urban Renewal Plan before the City Council at its meeting which commences at 6:00 P.M. on June 20, 2023, in the Council Chambers, City Hall, 215 East Washington Street, Washington, Iowa.

Section 4. That the City Clerk is authorized and directed to publish notice of this public hearing in the Southeast Iowa Union, once on a date not less than four (4) nor more than twenty (20) days before the date of the public hearing, and to mail a copy of the notice by ordinary mail to each affected taxing entity, such notice in each case to be in substantially the following form:

(One publication required)

NOTICE OF PUBLIC HEARING TO CONSIDER APPROVAL  
OF A PROPOSED WASHINGTON EAST COMMERCIAL  
URBAN RENEWAL PLAN FOR A PROPOSED URBAN  
RENEWAL AREA IN THE CITY OF WASHINGTON, STATE  
OF IOWA

The City Council of the City of Washington, State of Iowa, will hold a public hearing before itself at its meeting which commences at 6:00 P.M. on June 20, 2023 in the Council Chambers, City Hall, 215 East Washington Street, Washington, Iowa, to consider adoption of a proposed Washington East Commercial Urban Renewal Plan (the "Plan") concerning a proposed Urban Renewal Area in the City of Washington, State of Iowa.

The Washington East Commercial Urban Renewal Area is proposed to contain the land legally described as follows:

The West 10 acres of the East Half of the Southwest Quarter of the Southeast Quarter of Section 16, Township 75 North, of Range 7 West of the 5<sup>th</sup> P.M., in Washington County, Iowa.

A copy of the Plan is on file for public inspection in the office of the City Clerk, City Hall, City of Washington, Iowa.

The City of Washington, State of Iowa is the local public agency which, if such Plan is approved, shall undertake the urban renewal activities described in such Plan.

The general scope of the urban renewal activities under consideration in the Plan is to promote the growth and retention of qualified industries and businesses in the Urban Renewal Area through various public purpose and special financing activities outlined in the Plan. To accomplish the objectives of the Plan, and to encourage the further economic development of the Urban Renewal Area, the Plan provides that such special financing activities may include, but not be limited to, the making of loans or grants of public funds to private entities under Chapter 15A, Code of Iowa. The City also may reimburse or directly undertake the installation, construction and reconstruction of substantial public improvements, including, but not limited to, street, water, sanitary sewer, storm sewer or other public improvements. The City also may acquire and make land available for development or redevelopment by private enterprise as authorized by law. The Plan provides that the City may issue bonds or use available funds for purposes allowed by the Plan and that tax increment reimbursement of the costs of urban renewal projects may be sought if and to the extent incurred by the City. The Plan initially proposes no specific public infrastructure or site improvements to be undertaken by the City, and provides that the Plan may be amended from time to time.

Any person or organization desiring to be heard shall be afforded an opportunity to be heard at such hearing.

This notice is given by order of the City Council of the City of Washington, State of Iowa, as provided by Section 403.5, Code of Iowa.

Dated this \_\_\_\_\_ day of \_\_\_\_\_, 2023.

\_\_\_\_\_  
City Clerk, City of Washington, State of Iowa

(End of Notice)

Section 5. That the proposed Urban Renewal Plan, attached hereto as Exhibit 1, for the proposed Urban Renewal Area described therein is hereby officially declared to be the proposed Urban Renewal Plan referred to in the notices for purposes of such consultation and hearing and that a copy of the Plan shall be placed on file in the office of the City Clerk.

Section 6. That the Mayor and City Clerk are hereby authorized and directed to sign the Joint Agreement included as Exhibit C to the Urban Renewal Plan on behalf of the City, and that the City Clerk is hereby authorized and directed to submit a request to the Board of Supervisors of Washington County, Iowa for their approval of the Joint Agreement, with respect to the City's establishment of the proposed Urban Renewal Area within each city's "area of operation," as defined in Iowa Code Section 403.17(4).

Section 7. That the proposed Urban Renewal Plan be submitted to the Planning and Zoning Commission for review and recommendation as to its conformity with the general plan for the development of the City as a whole, with such recommendation to be submitted in writing to this Council within thirty (30) days of the date hereof.

PASSED AND APPROVED this 16<sup>th</sup> day of May, 2023.

\_\_\_\_\_  
Mayor

ATTEST:

\_\_\_\_\_  
City Clerk

Label the Plan as Exhibit 1 (with all exhibits) and attach it to this Resolution.

ATTACH THE PLAN LABELED AS  
EXHIBIT 1 HERE

CERTIFICATE

STATE OF IOWA )  
 ) SS  
COUNTY OF WASHINGTON )

I, the undersigned City Clerk of the City of Washington, State of Iowa, do hereby certify that attached is a true and complete copy of the portion of the records of the City showing proceedings of the Council, and the same is a true and complete copy of the action taken by the Council with respect to the matter at the meeting held on the date indicated in the attachment, which proceedings remain in full force and effect, and have not been amended or rescinded in any way; that meeting and all action thereat was duly and publicly held in accordance with a notice of meeting and tentative agenda, a copy of which was timely served on each member of the Council and posted on a bulletin board or other prominent place easily accessible to the public and clearly designated for that purpose at the principal office of the Council pursuant to the local rules of the Council and the provisions of Chapter 21, Code of Iowa, upon reasonable advance notice to the public and media at least twenty-four hours prior to the commencement of the meeting as required by law and with members of the public present in attendance; I further certify that the individuals named therein were on the date thereof duly and lawfully possessed of their respective city offices as indicated therein, that no Council vacancy existed except as may be stated in the proceedings, and that no controversy or litigation is pending, prayed or threatened involving the incorporation, organization, existence or boundaries of the City or the right of the individuals named therein as officers to their respective positions.

WITNESS my hand and the seal of the Council hereto affixed this \_\_\_\_\_ day of \_\_\_\_\_, 2023.

\_\_\_\_\_  
City Clerk, City of Washington, State of Iowa

(SEAL)

02205233-1\11307-066



NOTICE OF A CONSULTATION TO BE HELD BETWEEN THE  
CITY OF WASHINGTON, STATE OF IOWA AND ALL  
AFFECTED TAXING ENTITIES CONCERNING THE  
PROPOSED WASHINGTON EAST COMMERCIAL URBAN  
RENEWAL PLAN FOR THE CITY OF WASHINGTON, STATE  
OF IOWA

The City of Washington, State of Iowa will hold a consultation with all affected taxing entities, as defined in Section 403.17(1), Code of Iowa, as amended, commencing at 1:00 P.M. on May 25, 2023, in the Council Chambers, City Hall, 215 East Washington Street, Washington, Iowa concerning a proposed Washington East Commercial Urban Renewal Plan for the Washington East Commercial Urban Renewal Area, a copy of which is attached hereto.

Each affected taxing entity may appoint a representative to attend the consultation. The consultation may include a discussion of the estimated growth in valuation of taxable property included in the proposed Urban Renewal Area, the fiscal impact of the division of revenue on the affected taxing entities, the estimated impact on the provision of services by each of the affected taxing entities in the proposed Urban Renewal Area, and the duration of any bond issuance included in the Plan.

The designated representative of any affected taxing entity may make written recommendations for modifications to the proposed division of revenue no later than seven days following the date of the consultation. The City Administrator, or her delegate, as the designated representative of the City of Washington, State of Iowa, shall submit a written response to the affected taxing entity, no later than seven days prior to the public hearing on the proposed Washington East Commercial Urban Renewal Plan, addressing any recommendations made by that entity for modification to the proposed division of revenue.

This notice is given by order of the City Council of the City of Washington, State of Iowa, as provided by Section 403.5, Code of Iowa, as amended.

Dated this \_\_\_\_\_ day of \_\_\_\_\_, 2023.

\_\_\_\_\_  
City Clerk, City of Washington, State of Iowa

(End of Notice)

Instructions for the Certificate of Mailing of Notices  
IMPORTANT

All three of the following documents must be signed, dated and MAILED to the taxing entities and attached to the Certificate of Mailing of Notices that should be immediately returned to our office:

- 1) The single page entitled "Notice of a Consultation" AND
- 2) The 2 page document entitled "Notice of Public Hearing" AND
- 3) The entire resolution with the Plan attached. (The Notice of a Consultation and the Notice of Public Hearing will be repeated in this document, but you will need to mail all three of the documents to the affected taxing entities.)

Make sure to address the envelopes to the County and the public school district(s) in the Urban Renewal Area as follows:

"Board of Supervisors of Washington County, c/o County Auditor"; and

"Washington Community School District, c/o President or Secretary of the Board of Directors."

Note: If we don't receive this Certificate (with attachments) back ASAP after it is mailed, we will not be able to determine that the appropriate notices have been sent to start the Plan process.

CERTIFICATE OF MAILING OF NOTICES OF  
CONSULTATION AND HEARING

I, the undersigned, City Clerk of the City of Washington, State of Iowa, do hereby certify that on the \_\_\_\_\_ day of \_\_\_\_\_, 2023, I caused there to be deposited and mailed in the United States mail at Washington, Iowa, properly stamped and addressed, a copy of the following-described notices, each in the form attached hereto, to each school district, county or city, as applicable, which levied or certified for levy a property tax on any portion of the taxable property located within the proposed Washington East Commercial Urban Renewal Area in the fiscal year beginning prior to the calendar year in which the Plan was submitted to the City Council for approval:

- 1) NOTICE OF A CONSULTATION TO BE HELD BETWEEN THE CITY OF WASHINGTON, STATE OF IOWA, AND ALL AFFECTED TAXING ENTITIES CONCERNING THE PROPOSED WASHINGTON EAST COMMERCIAL URBAN RENEWAL PLAN FOR THE CITY OF WASHINGTON, STATE OF IOWA; AND
- 2) NOTICE OF PUBLIC HEARING TO CONSIDER APPROVAL OF A PROPOSED WASHINGTON EAST COMMERCIAL URBAN RENEWAL PLAN FOR A PROPOSED URBAN RENEWAL AREA IN THE CITY OF WASHINGTON, STATE OF IOWA.
- 3) RESOLUTION SETTING DATES FOR CONSULTATION AND PUBLIC HEARING WITH PLAN ATTACHED AS EXHIBIT 1.

The affected taxing entities and their mailing addresses are as follows:

Washington Community School District

\_\_\_\_\_  
c/o Secretary or Board President  
\_\_\_\_\_

\_\_\_\_\_  
(Insert address)

Board of Supervisors of Washington  
County

\_\_\_\_\_  
c/o Washington County Auditor  
\_\_\_\_\_

\_\_\_\_\_  
(Insert address)

Note: Community College is not an "affected taxing entity" as of 7/1/2012.

Note: The City has confirmed that the above school(s) and county(ies) are the only entities within the entire urban renewal area. If this is not correct, the notices and resolution must be sent to **all** schools and counties within the **entire** urban renewal area.

WITNESS my hand and the seal of the City at Washington, Iowa, this \_\_\_\_\_ day of \_\_\_\_\_, 2023.

\_\_\_\_\_  
City Clerk, City of Washington, State of Iowa

(SEAL)

**Attach copies of the items listed above, that were mailed to this Certificate and send the Certificate and attachments to Ahlers & Cooney, P.C.**

02205240-1\11307-066

(One publication required)

NOTICE OF PUBLIC HEARING TO CONSIDER APPROVAL  
OF A PROPOSED WASHINGTON EAST COMMERCIAL  
URBAN RENEWAL PLAN FOR A PROPOSED URBAN  
RENEWAL AREA IN THE CITY OF WASHINGTON, STATE  
OF IOWA

The City Council of the City of Washington, State of Iowa, will hold a public hearing before itself at its meeting which commences at 6:00 P.M. on June 20, 2023 in the Council Chambers, City Hall, 215 East Washington Street, Washington, Iowa, to consider adoption of a proposed Washington East Commercial Urban Renewal Plan (the "Plan") concerning a proposed Urban Renewal Area in the City of Washington, State of Iowa.

The Washington East Commercial Urban Renewal Area is proposed to contain the land legally described as follows:

The West 10 acres of the East Half of the Southwest Quarter of the Southeast Quarter of Section 16, Township 75 North, of Range 7 West of the 5<sup>th</sup> P.M., in Washington County, Iowa.

A copy of the Plan is on file for public inspection in the office of the City Clerk, City Hall, City of Washington, Iowa.

The City of Washington, State of Iowa is the local public agency which, if such Plan is approved, shall undertake the urban renewal activities described in such Plan.

The general scope of the urban renewal activities under consideration in the Plan is to promote the growth and retention of qualified industries and businesses in the Urban Renewal Area through various public purpose and special financing activities outlined in the Plan. To accomplish the objectives of the Plan, and to encourage the further economic development of the Urban Renewal Area, the Plan provides that such special financing activities may include, but not be limited to, the making of loans or grants of public funds to private entities under Chapter 15A, Code of Iowa. The City also may reimburse or directly undertake the installation, construction and reconstruction of substantial public improvements, including, but not limited to, street, water, sanitary sewer, storm sewer or other public improvements. The City also may acquire and make land available for development or redevelopment by private enterprise as authorized by law. The Plan provides that the City may issue bonds or use available funds for purposes allowed by the Plan and that tax increment reimbursement of the costs of urban renewal projects may be sought if and to the extent incurred by the City. The Plan initially proposes no specific public infrastructure or site improvements to be undertaken by the City, and provides that the Plan may be amended from time to time.

Any person or organization desiring to be heard shall be afforded an opportunity to be heard at such hearing.

This notice is given by order of the City Council of the City of Washington, State of Iowa, as provided by Section 403.5, Code of Iowa.

Dated this \_\_\_\_\_ day of \_\_\_\_\_, 2023.

\_\_\_\_\_  
City Clerk, City of Washington, State of Iowa

(End of Notice)

02205434-111307-066



# Washington Police Department

James Lester, Chief of Police

215 East Washington Street

Washington, Iowa 52353

Phone: 319-653-2256 Dispatch: 319-653-2107

Rhonda Hill  
Administrative Assistant

May 11, 2023

Lyle Hansen  
Lieutenant

To: City Council

Shamus Altenhofen  
Lieutenant

Cc: City Administrator Deanna McCusker, Sally Hart, City Clerk & Kelsey Brown,  
Finance Director

Jason Chalupa  
Sergeant

Ref.: Police Department Fee Schedule

Benjamin Altenhofen  
Sergeant

In December 2020 the City Council approved a Police Department Fee Schedule.

Brian VanWilligen  
Investigator

All public records requests are processed in accordance with Iowa law, unless the information requested falls under the limited exceptions outlined in Iowa Code 22.7 or another law. In those cases, we are sometimes served a subpoena or court order requiring us to produce the documents or recordings.

Eric Kephart  
K-9 Handler

Seth Adam  
Police Officer

The Iowa Code allows government bodies to charge "reasonable" fees for fulfilling records requests, but the fees are not to exceed the actual costs incurred in providing the service. The Code also allows for the collection of fees for serving certain court documents.

Tanner Lavelly  
Police Officer

Mia Brdecka  
Police Officer

Recent legislation changes indicate, "the lawful custodian shall make every reasonable effort to provide the public record requested at no cost other than copying costs for a record which takes less than thirty minutes to produce."

Colton Schneider  
Police Officer

I have edited our Fee Schedule to comply with the thirty (30) minutes included in the recent revisions. I am requesting the City Council approve the attached Washington Police Department Fee Schedule with an effective date of June 1, 2023.

Respectfully submitted,

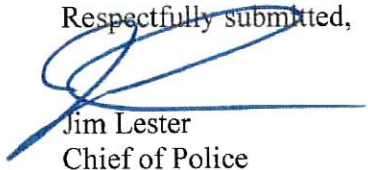
  
Jim Lester  
Chief of Police

# Washington Police Department

215 East Washington Street  
Washington, Iowa 52358  
Phone: 319-653-2256 Dispatch: 319-653-2107

## FEE SCHEDULE

Effective: June 1, 2023

Description	Fee
Copy Fee	.50 per page
Calls for Service Report	.50 per page + per hour fee for time spent over 30 minutes in gathering data
State Accident Report	\$4.00
Incident Report (Does not include officer investigative narrative)	\$4.00
Copies of Incident Photos / Videos	\$25 per 16 GB flash drive + per hour fee for time spent over 30 minutes in gathering data. (Personal flash drives are not allowed) (One incident per flash drive)
Per hour fee for gathering data	\$25.00 - billed in 30-minute increments
Personal Service of Notices/Subpoenas	\$30 + copy fees
Local Records Check (City of Washington records only)	\$5 + .50 per page + per hour fee for time spent over 30 minutes in gathering data.
Off-Duty Officer Special Event per hour	\$70 per hour / per officer
Impound and Storage of Vehicles	Actual towing fee + \$5 per day

**NOTE:** Copies of requested materials may be reasonably delayed for up to ten (10) business days. Examination and/or release of confidential information is prohibited.

Pre-payment of fees may be required for some requests.

Some requested items including photos and/or video may be sent via email or through the department's video management system with the approval of the Chief of Police.

Actual costs for mailing/shipping/delivery may be assessed.

Specific information that may not be released includes but is not limited to: 1. Peace Officer investigative reports; 2. Social Security numbers; 3. Intelligence data per Iowa Code 692; 4. Registered victim information and identities of child victims per Iowa Code 915; 5. Results and reports of psychological, medical and mental health examinations; 6. Cases or investigations that have not been completed.





# GARDEN & ASSOCIATES, LTD.

1701 3<sup>rd</sup> Avenue East, Suite 1 • P.O. Box 451 • Oskaloosa, IA 52577

Phone: 641.672.2526 • Fax: 641.672.2091

April 28, 2023

Deanna McCusker, City Administrator  
City of Washington  
215 E. Washington Street  
Washington, IA 52353

Re: Buchanan Street Paving & Reconstruction  
Washington, Iowa  
STBG-SWAP-8140(612)—SG-92  
G&A 5020201

Dear Deanna:

Enclosed herewith for your review and approval is one (1) copy of Pay Application No. 12 for the referenced project. As shown, the payment due to the contractor is \$16,777.34, of this \$15,885.77 will be reimbursed by the Iowa Department of Transportation for participating items at this time per the attached "Claim for Reimbursement" form.

Also enclosed is Change Order No. 3 which is the final quantity adjust change order and includes the pavement thickness incentive due the contractor per specifications in the amount of \$16,343.34. The overall change order increases the project by \$51,261.59.

If the Council approves the pay application and change order, sign the documents in Doc Express and forward payment to DeLong Construction, Inc.

After you have reviewed, please contact me with any questions or comments.

Sincerely,  
**GARDEN & ASSOCIATES, LTD.**

Jack Pope, P.E.

Enc: Pay Application No. 12 (1 copy)  
Change Order No. 3 (1 copy)  
Claim for Reimbursement #12

JP/fs

**CHANGE ORDER**  
For Local Public Agency Projects

No.: 3

Non-Substantial:

Apr 10, 2023

Substantial:

Administering Office  
Concurrence Date

Accounting ID No. (5-digit number): 37804

Project Number: STBG-SWAP-8140(612)--SG-92

Contract Work Type: PCC Pavement - Replace

Local Public Agency: City of Washington

Contractor: DeLong Construction, Inc.

Date Prepared: December 6, 2022

You are hereby authorized to make the following changes to the contract documents.

**A - Description of change to be made:**

Adjustment of final contract quantities to reflect as built conditions.

- 0020 - increase project quantity
- 0050 - increase project quantity
- 0110 - increase project quantity
- 0260 - increase project quantity
- 0270 - increase project quantity
- 0280 - increase project quantity
- 0290 - increase project quantity
- 0310 - increase project quantity
- 0330 - decrease project quantity
- 0340 - decrease project quantity
- 0350 - decrease project quantity
- 0370 - increase project quantity
- 0380 - increase project quantity
- 0400 - decrease project quantity
- 0410 - increase project quantity
- 0470 - increase project quantity
- 0490 - increase project quantity
- 0500 - decrease project quantity
- 0540 - decrease project quantity
- 0570 - decrease Project quantity
- 0590 - increase project quantity
- 0690 - decrease project quantity
- 0720 - decrease project quantity
- 0730 - increase project quantity
- 0740 - increase project quantity
- 0750 - increase project quantity
- 0760 - decrease project quantity
- 0770 - decrease project quantity
- 0780 - decrease project quantity
- 8004 - Add item Incentive/Disincentive for PCC Pavement Thickness 7"
- 8005 - Add item Incentive/Disincentive for PCC Pavement Thickness 8"

**B - Reason for change:**

Field conditions at time of construction.

- 0020 -Additional Excavation required for poor subgrade requiring an additional 485 CY
- 0050 -Additional subbase treatment required for poor soils requiring an additional 485 CY
- 0110 - Additional drive not on plans required 98.41 Tons of granular surfacing
- 0260 - Quantity on original plans not accurate, increased quantity by 15.0 LF
- 0270 - Quantity on original plans not accurate, increased quantity by 22.0 LF
- 0280 - Quantity on original plans not accurate, increased quantity by 12.0 LF
- 0290 - Slight adjustment in structure location to avoid existing utilities, quantity increased by 3.0 LF
- 0310 - Slight adjustment in structure location to avoid existing utilities, quantity increased by 4.0 LF

- 0330 - Existing pipe location at location that allowed for reduction in quantity, reduced by 5.0 LF
- 0340 - Slight adjustment in structure location to avoid existing utilities, quantity decreased by 6.0 LF
- 0350 - Slight adjustment in structure location to avoid existing utilities, quantity decreased by 4.0 LF
- 0370 - Quantity on original plans not accurate, decreased quantity by 12.0 LF
- 0380 - Sanitary Stub was not required to be installed as shown on plans, reduced by 3.0 LF
- 0400 - Existing conditions allowed for the use of less revetment stone, decreased by 19.16 Ton
- 0410 - Stream bank condition required additional erosion stone, increased by 24.43 Ton
- 0470 - During driveway removal bad section of existing drive removed increasing quantity by 10.0 SY
- 0490 - Construction of retaining wall was slightly raised to match field conditions heights, increased quantity by 7.51 CY
- 0500 - Contractor was able to avoid removal of field fence, quantity for removal and replacement reduced by 245.0 LF
- 0540 - Trench Foundation not required quantity reduced by 100.0 Ton
- 0570 - Existing water found to be at different location than planned, decreased quantity by 90.0 LF
- 0590 - Existing water services too shallow and had to be replaced increased quantity by 228.0 LF
- 0690 - No drain tile encountered during construction, quantity reduced by 250.0 LF
- 0720 - Temporary granular surfacing not used during construction was reduced by 86.94 Tons because of efficiencies
- 0730 - Mulching quantity increased because of increased rural seeding below, quantity 7.6 Ac.
- 0740 - Additional rural areas disturbed by construction and approved by jurisdiction increased by 8.4 Ac.
- 0750 - Quantity of urban seeding reduced and replaced by rural seeding, reduced by 0.80 Ac.
- 0760 - Control devices not needed during construction, quantity reduced by 2132.0 LF
- 0770 - Control device quantity reduced so removal quantity reduced by 2132.0 LF
- 0780 - Not all mobilizations for erosion control were required. Quantity decreased by 1.0
- 8004 - Incentive earned is based upon the results of the 9-point measurements of the required random core samples taken and compared to the Standard Specification 2301.05, A, 2 Table 2301.05-1.
- 8005 - Incentive earned is based upon the results of the 9-point measurements of the required random core samples taken and compared to the Standard Specification 2301.05, A, 2 Table 2301.05-1.

C - Settlement for cost(s) of change as follows with items addressed in Sections F and/or G:

0020, 0050, 0110, 0260, 0270, 0280, 0290, 0310, 0330, 0340, 0350, 0370, 0380, 0400, 0410, 0470, 0490, 0500, 0540, 0570 0590, 0690, 0720, 0730, 0740, 0750, 0760, 0770, and 0780 - Contract unit price.

8004, 8005 - Specified Unit Price

D - Justification for cost(s) (See I.M. 3.805, Attachment D, Chapter 2.36, for acceptable justification):

8004, 8005 - Per Standard Specification 2301.05, A, 2 Table 2301.05-1

Accounting ID No.(5-digit number): \_\_\_\_\_

Change Order No.: \_\_\_\_\_

E - Contract time adjustment:     No Working Days added     Working Days added: \_\_\_\_\_     Unknown at this time

Justification for selection:  
The plan revisions do not cause a change in contract time.

F - Items included in contract:

Participating		Line Number	Item Description	For deductions enter as "-x.xx"		Amount .xx
Federal-aid	State-aid			Unit Price .xx	Quantity .xxx	
	x	0020	Excavation, Class 13, Roadway and Borrow (Div 1)	\$2.95	485.000	\$1,430.75
	x	0050	Modified Subbase (Div 1)	\$39.35	485.000	\$19,084.75
	x	0110	Granular Surfacing on Road, Class A (Div 1)	\$25.00	98.410	\$2,460.25
	x	0260	Storm Sewer Gravity Main, Trenched, 15 in. (Div 1)	\$35.75	15.000	\$536.25
	x	0270	Storm Sewer Gravity Main, Trenched, 18 in. (Div 1)	\$42.60	22.000	\$937.20
	x	0280	Storm Sewer Gravity Main, Trenched, 21 in. (Div 1)	\$58.10	12.000	\$697.20
	x	0290	Storm Sewer Gravity Main, Trenched, 24 in. (Div 1)	\$59.40	3.000	\$178.20
	x	0310	Storm Sewer Gravity Main, Trenched, 36 in. (Div 1)	\$101.40	4.000	\$405.60
	x	0330	Storm Sewer Gravity Main, Trenched, PVC 8 in. (Div 1)	\$19.20	-5.000	-\$96.00
	x	0340	Storm Sewer Gravity Main, Trenched, RCP, 15 in. (Div 1)	\$47.50	-6.000	-\$285.00
	x	0350	Storm Sewer Gravity Main, Trenched, RCP, 18 in. (Div 1)	\$58.95	-4.000	-\$235.80
		0370	Sanitary Sewer Gravity Main, Trenched, PVC 8 in. (Div 2)	\$41.30	12.000	\$495.60
		0380	Sanitary Sewer Service Stub, Trenched, PVC 6 in. (Div 2)	\$35.80	3.000	\$107.40
	x	0400	Revetment, Class D (Div 1)	\$43.00	-19.160	-\$823.88
	x	0410	Erosion Stone (Div 1)	\$95.00	24.430	\$2,320.85
	x	0470	Driveway, P.C. Concrete, 6 in. (Div 1)	\$51.20	10.000	\$512.00
	x	0490	Combined Concrete Sidewalk and Retaining (Div 1)	\$528.00	7.510	\$3,965.28
	x	0500	Removal and Re-installation of Fence, Field (Div 1)	\$6.50	-245.000	-\$1,592.50
	x	0540	Trench Foundation (Div 1)	\$33.00	-100.000	-\$3,300.00
		0570	Water Main Trenched, PVC 12" (Div 2)	\$54.20	-90.000	-\$4,878.00
		0590	Water Service Stub, Copper, 1 in. (Div 2)	\$61.00	228.000	\$13,908.00
	x	0690	Repair Damaged Tile 4 in. or 6 in. (Div 1)	\$20.00	-250.000	-\$5,000.00
	x	0720	Temporary Granular Surfacing (Div 1)	\$25.00	-86.940	-\$2,173.50
	x	0730	Mulching (Div 1)	\$700.00	7.600	\$5,320.00
	x	0740	Seeding and Fertilizing (Rural) (Div 1)	\$1,000.00	8.400	\$8,400.00
	x	0750	Seeding and Fertilizing (Urban) (Div 1)	\$1,500.00	-0.800	-\$1,200.00
	x	0760	Perimeter & Slope Sediment Control Device 9 in. (Div 1)	\$2.20	-2,132.000	-\$4,690.40

Federal-aid	State-aid	Line Number	Item Description	Unit Price .xx	Quantity .xxx	Amount .xx
	x	0770	Removal of Perimeter & Slope Protection (Div 1)	\$0.50	-2,132.000	-\$1,066.00
	x	0780	Mobilization, Erosion Control (Div 1)	\$500.00	-1.000	-\$500.00
<input type="button" value="Add Row"/> <input type="button" value="Delete Row"/>						TOTAL
						\$34,918.25

G - Items not included in contract:

Participating				For deductions enter as "-x.xx"			
Federal-aid	State-aid	Change Number	Item Number	Item Description	Unit Price .xx	Quantity .xxx	Amount .xx
	x	8004	2301-7000110	Incentive/Disincentive for PCC Thickness 7" (Div 1)	\$1.00	7,669.080	\$7,669.08
	x	8005	2301-7000110	Incentive/Disincentive for PCC Thickness 8" (Div 1)	\$1.00	8,674.260	\$8,674.26
				16,343.34			
<input type="button" value="Add Row"/> <input type="button" value="Delete Row"/>						TOTAL	
						\$16,343.34	

H. Signatures

Agreed:

Contractor \_\_\_\_\_ Date \_\_\_\_\_

Recommended:

Project Engineer \_\_\_\_\_ Date \_\_\_\_\_

Approved:

Person In Responsible Charge \_\_\_\_\_ Date \_\_\_\_\_ Other (optional) \_\_\_\_\_ Title \_\_\_\_\_ Date \_\_\_\_\_

Contracting Authority (optional) \_\_\_\_\_ Date \_\_\_\_\_ Other (optional) \_\_\_\_\_ Title \_\_\_\_\_ Date \_\_\_\_\_

Iowa DOT Administering Office \_\_\_\_\_ Date \_\_\_\_\_

Approval is contingent upon funds being available under the existing project agreement or upon additional Federal-aid funds being made available by a modified project agreement.

FHWA Concurrence: \_\_\_\_\_ Date \_\_\_\_\_  
Federal Highway Division Administration  
(if required)

DISTRIBUTION (after fully executed on LPA projects): Original - Finance; Copies - Contractor, Project Engineer, Contracting Authority, Administering Office.

Date distributed: \_\_\_\_\_ Initials: \_\_\_\_\_

IOWA DEPARTMENT OF TRANSPORTATION  
ACCEPTANCE AND ASSURANCE TESTING OF PCC CORE THICKNESS  
OFFICE OF CONSTRUCTION AND MATERIALS

PROJECT # : STBG-SWAP-8140(612)-SG-92

ACCOUNTING ID # : 37804

# OF SECTIONS ON PROJECT : 2

THIS SECTION # : 1

# OF LOTS IN THIS SECTION : 10

CONTRACTOR : DeLong Construction

COUNTY : WASHINGTON

BEGINNING CORE # : 50011

ENDING CORE # : 50020

SAMPLED BY :

MEASURED BY : COLBY WILSON

IA CHECKED BY :

DME:

RCE:

REMARKS :

PAY SUMMARY

DESIGN THICKNESS :	7.00
ORIGINAL AVERAGE THICKNESS OF ALL CORES IN SECTION :	7.93
ORIGINAL STANDARD DEV. (N-1) OF SECTION :	0.51
ORIGINAL TI INDEX FOR PCC THICKNESS :	0.42
ORIGINAL % PAYMENT OF SECTION :	103
NUMBER OF DEFICIENT DEPTH CORES :	0
NUMBER OF CORES 3 STDDEV THICKER THAN PLAN THICKNESS :	1
10% OF ALL CORES IN SECTION (maximum that can be removed) :	1
ADJUSTED AVERAGE THICKNESS OF ALL CORES IN SECTION :	
ADJUSTED STANDARD DEV. (N-1) OF SECTION :	
ADJUSTED TI INDEX FOR PCC THICKNESS :	
ADJUSTED % PAYMENT OF SECTION :	
DOLLAR INCENTIVE OR DISINCENTIVE :	\$7,669.08

IOWA DEPARTMENT OF TRANSPORTATION  
ACCEPTANCE AND ASSURANCE TESTING OF PCC CORE THICKNESS  
OFFICE OF CONSTRUCTION AND MATERIALS

PROJECT # : STBG-SWAP-8140(612)-SG-92

ACCOUNTING ID # : 37804

# OF SECTIONS ON PROJECT : 2

THIS SECTION # : 1

# OF LOTS IN THIS SECTION : 10

CONTRACTOR : DeLong Construction

COUNTY : WASHINGTON

BEGINNING CORE # : 50001

ENDING CORE # : 50010

SAMPLED BY :

MEASURED BY : COLBY WILSON

IA CHECKED BY :

DME: \_\_\_\_\_

RCE: \_\_\_\_\_

REMARKS :

PAY SUMMARY

DESIGN THICKNESS :	8.00
ORIGINAL AVERAGE THICKNESS OF ALL CORES IN SECTION :	8.69
ORIGINAL STANDARD DEV. (N-1) OF SECTION :	0.46
ORIGINAL TI INDEX FOR PCC THICKNESS :	0.23
ORIGINAL % PAYMENT OF SECTION :	103
NUMBER OF DEFICIENT DEPTH CORES :	0
NUMBER OF CORES 3 STDEV THICKER THAN PLAN THICKNESS :	0
10% OF ALL CORES IN SECTION (maximum that can be removed) :	1
ADJUSTED AVERAGE THICKNESS OF ALL CORES IN SECTION :	
ADJUSTED STANDARD DEV. (N-1) OF SECTION :	
ADJUSTED TI INDEX FOR PCC THICKNESS :	
ADJUSTED % PAYMENT OF SECTION :	
DOLLAR INCENTIVE OR DISINCENTIVE :	\$8,674.26



# Doc Express® Document Signing History

Contract: 92-8140-612 Document: Change Order 3

This document is in the process of being signed by all required signatories using the Doc Express® service. Following are the signatures that have occurred so far.

Date	Signed By
04/29/2023	Jack Pope Garden & Associates LTD Electronic Signature (Recommended by Engineer / Approved)
	(Approved by PIRC (when applicable))
	(Approved by Administering Office or designee)
	(Approved by FHWA (when applicable))



ENGINEERS JOINT CONTRACT DOCUMENTS COMMITTEE

### Contractor's Application for Payment No. 12

To (Owner):	City of Washington, Iowa	Application Period:	11/4/22-04/10/23	Application Date:	4/10/2023
Project:	West Buchanan Street Paving & Reconstruction - Washington, Iowa	From (Contractor):	DeLong Construction, Inc.	Via (Engineer):	Garden & Associates, LTD.
Owner's Contract No.:	STBG-SWAP-814M612-SG-92	Contractor's Project No.:		Engineer's Project No.:	5020201

Contract Working Day Summary:

Original Contract Time: 90  
 Added by Change Order: \_\_\_\_\_  
 Contract Time To Date: 90  
 Working Days Used to Date: 128.5  
 Working Days Remaining: -38.5

### Application For Payment Change Order Summary

Approved Change Orders Number	Additions	Deductions
1	\$12,775.00	\$61,871.35
2	\$51,261.59	
3		
<b>TOTALS</b>	\$64,036.59	\$61,871.35
<b>NET CHANGE BY CHANGE ORDERS</b>	\$2,165.24	

1. ORIGINAL CONTRACT PRICE: \$ 51,714,667.30
2. Net change by Change Orders: \$ 2,165.24
3. Current Contract Price (Line 1 ± 2): \$ 51,716,832.54
4. TOTAL COMPLETED AND STORED TO DATE (Work from Progress Estimates): \$ 51,716,832.54
5. RETAINAGE:
  - a. 3% X \$1,716,832.54 Work Completed: \$ 330,000.00
  - b. 3% X \_\_\_\_\_ Stored Material: \$ \_\_\_\_\_
  - c. Total Retainage (Line 5.a + Line 5.b): \$ 330,000.00
6. AMOUNT ELIGIBLE TO DATE (Line 4 - Line 5.c): \$ 51,686,832.54
7. LESS PREVIOUS PAYMENTS (Line 6 from prior Application): \$ 51,670,055.20
8. AMOUNT DUE THIS APPLICATION: \$ 16,777.34
9. BALANCE TO FINISH, PLUS RETAINAGE (Column G total on Progress Estimates + Line 5.c above): \$ 330,000.00

**Contractor's Certification**

The undersigned Contractor certifies, to the best of its knowledge, the following:

(1) All previous progress payments received from Owner on account of Work done under the Contract have been applied on account to discharge Contractor's legitimate obligations incurred in connection with the Work covered by prior Applications for Payment.

(2) Title to all Work, materials and equipment incorporated in said Work, or otherwise listed in or covered by this Application for Payment, will pass to Owner at time of payment free and clear of all Liens, security interests, and encumbrances (except such as are covered by a bond acceptable to Owner indemnifying Owner against any such Liens, security interests, or encumbrances); and

(3) All the Work covered by this Application for Payment is in accordance with the Contract Documents and is not defective.

Contractor Signature: *Paul DeLong* Date: 4-27-23

Payment of: \$ 16,777.34 (Line 8 or other - attach explanation of the other amount)

is recommended by: *Paul DeLong* (Engineer) Date: 4-27-2023

Payment of: \$ 16,777.34 (Line 8 or other - attach explanation of the other amount)

is approved by: \_\_\_\_\_ (Owner) Date: \_\_\_\_\_

Pay Application No. 12  
 Most Buchanan Street Paving & Reconstruction  
 Washington, Iowa  
 Project Number: STRG-SWAP-8140(612)-56-92  
 April 18, 2023

Delong Construction, Inc.

Item Number	Item Code	Item	Unit	Division 1	Division 2	Non-Part.	Division 1	Division 2	Total	Unit Price	Ext.	Ext.	Total
				Total	Total	Total	Total	Total	Total	Price	Price	Price	Price
1	2101-0850003	CLEARING AND GRUBBING	400	400			400		400	\$28.00	\$11,200.00		\$11,200.00
2	2102-2130109	EXCAVATION, CLASS 3, ROADWAY AND BORROW	8036				8036		8036	\$28.95	\$232,889.23		\$232,889.23
3	2105-8425015	TOPSOIL, STRIP, SALVAGE AND SPREAD	1500				1500		1500	\$4.98	\$7,470.00		\$7,470.00
4	2109-8251504	SPECIAL COMPACTON OF SUBGRADE	2878				2878		2878	\$435.00	\$1,251,930.00		\$1,251,930.00
5	2115-0100000	MODIFIED SUBBASE	1085				1085		1085	\$99.35	\$107,840.50		\$107,840.50
6	2123-7450029	SHOULDER FINISHING, EARTH	68.47				68.47		68.47	\$375.00	\$25,674.25		\$25,674.25
7	2211-0700409	RELOCATION OF MAIL BOXES	5				5		5	\$350.00	\$1,750.00		\$1,750.00
8	2301-1030009	STANDARD OR SLIP FORM PORTLAND CEMENT CONCRETE PAVEMENT, CLASS C, CLASS 3 DURABILITY, 7 IN.	5260				5260		5260	\$408.60	\$2,130,000.00		\$2,130,000.00
9	2301-1030009	STANDARD OR SLIP FORM PORTLAND CEMENT CONCRETE PAVEMENT, CLASS C, CLASS 3 DURABILITY, 8 IN.	5320				5320		5320	\$54.35	\$289,142.00		\$289,142.00
10	2301-6511722	PORTLAND CEMENT CONCRETE PAVEMENT SAMPLES	1				1		1	\$4,335.23	\$4,335.23		\$4,335.23
11	2312-8260051	GRANULAR SURFACING ON ROAD, CLASS A CRUSHED STONE	173.41				173.41		173.41	\$3,600.00	\$625,076.00		\$625,076.00
12	2401-6750001	REMOVALS, AS PER PLAN	1				1		1	\$4,720.00	\$4,720.00		\$4,720.00
13	2435-0130148	MANHOLE, SANITARY SEWER, SM-301, 48 IN.	2				2		2	\$5,625.00	\$11,250.00		\$11,250.00
14	2435-0140148	MANHOLE, STORM SEWER, SM-401, 48 IN.	4				4		4	\$6,000.00	\$24,000.00		\$24,000.00
15	2435-0140160	MANHOLE, STORM SEWER, SM-401, 60 IN.	1				1		1	\$9,745.00	\$9,745.00		\$9,745.00
16	2435-0140184	MANHOLE, STORM SEWER, SM-401, 84 IN.	2				2		2	\$8,715.00	\$17,430.00		\$17,430.00
17	2435-0250272	INTAKE, SM-502, 72 IN.	10				10		10	\$3,995.00	\$39,950.00		\$39,950.00
18	2435-0250700	INTAKE, SM-507	2				2		2	\$2,400.00	\$4,800.00		\$4,800.00
19	2435-0250900	INTAKE, SM-509	2				2		2	\$2,400.00	\$4,800.00		\$4,800.00
20	2435-0251224	INTAKE, SM-512, 24 IN.	1				1		1	\$2,395.00	\$2,395.00		\$2,395.00
21	2435-0251230	INTAKE, SM-512, 30 IN.	1				1		1	\$6,220.00	\$6,220.00		\$6,220.00
22	2435-0251300	INTAKE, SM-513	1				1		1	\$1,195.00	\$1,195.00		\$1,195.00
23	2435-0700043	CONNECTION TO EXISTING MANHOLE	1				1		1	\$5.65	\$5.65		\$5.65
24	2492-8212383	SUBDRAIN, LONGITUDINAL, (SHOULDER) 4 IN. DIA.	34				34		34	\$295.00	\$10,030.00		\$10,030.00
25	2502-8212383	SUBDRAIN OUTLET, DR.-303	768				768		768	\$35.75	\$27,456.00		\$27,456.00
26	2503-0110015	STORM SEWER GRAVITY MAIN, TRENCHED, 15 IN.	18				18		18	\$42.68	\$768.24		\$768.24
27	2503-0110018	STORM SEWER GRAVITY MAIN, TRENCHED, 18 IN.	278				278		278	\$58.18	\$16,173.84		\$16,173.84
28	2503-0110021	STORM SEWER GRAVITY MAIN, TRENCHED, 21 IN.	752				752		752	\$59.40	\$44,649.20		\$44,649.20
29	2503-0110024	STORM SEWER GRAVITY MAIN, TRENCHED, 24 IN.	233				233		233	\$75.00	\$17,595.00		\$17,595.00
30	2503-0110030	STORM SEWER GRAVITY MAIN, TRENCHED, 30 IN.	603				603		603	\$76.00	\$45,810.00		\$45,810.00
31	2503-0110035	STORM SEWER GRAVITY MAIN, TRENCHED, 36 IN.	440				440		440	\$161.00	\$71,240.00		\$71,240.00
32	2503-0110042	STORM SEWER GRAVITY MAIN, TRENCHED, 42 IN.	67				67		67	\$166.85	\$11,178.95		\$11,178.95
33	2503-0112005	STORM SEWER GRAVITY MAIN, TRENCHED, POLYVINYL CHLORIDE PIPE (PVC), 8 IN.	450				450		450	\$41.50	\$18,675.00		\$18,675.00
34	2503-0112120	STORM SEWER GRAVITY MAIN, TRENCHED, POLYVINYL CHLORIDE PIPE (PVC), 10 IN.	22				22		22	\$47.50	\$1,045.00		\$1,045.00
35	2503-0112125	STORM SEWER GRAVITY MAIN, TRENCHED, POLYVINYL CHLORIDE PIPE (PVC), 12 IN.	23				23		23	\$56.50	\$1,309.50		\$1,309.50
36	2503-0112135	STORM SEWER GRAVITY MAIN, TRENCHED, POLYVINYL CHLORIDE PIPE (PVC), 15 IN.	536				536		536	\$16.50	\$8,844.00		\$8,844.00
37	2503-0200036	REMOVED STORM SEWER PIPE LESS THAN OR EQUAL TO 36 IN.	1256				1256		1256	\$41.30	\$52,368.48		\$52,368.48
38	2504-0114008	SANITARY SEWER GRAVITY MAIN, TRENCHED, POLYVINYL CHLORIDE PIPE (PVC), 6 IN.	3				3		3	\$45.00	\$135.00		\$135.00
39	2504-0200040	SANITARY SEWER SERVICE STUB, POLYVINYL CHLORIDE PIPE (PVC), 6 IN.	125				125		125	\$45.00	\$5,625.00		\$5,625.00
40	2507-6800042	REVENTMENT, CLASS D	125				125		125	\$45.00	\$5,625.00		\$5,625.00
41	2507-8020000	FROSTION STONE	2230				2230		2230	\$9.00	\$20,070.00		\$20,070.00
42	2510-6745859	REMOVAL OF PAVEMENT	6				6		6	\$350.00	\$2,100.00		\$2,100.00
43	2510-6750000	REMOVAL OF INTKES AND UTILITY ACCESSSES	808				808		808	\$40.00	\$32,320.00		\$32,320.00
44	2511-7520005	SIDWALK, P.C. CONCRETE, 5 IN.	33				33		33	\$45.00	\$1,485.00		\$1,485.00
45	2511-7520006	SIDWALK, P.C. CONCRETE, 6 IN.	16				16		16	\$55.00	\$880.00		\$880.00
46	2511-7528101	DETECTABLE MANNINGS	446				446		446	\$51.20	\$22,855.20		\$22,855.20
47	2515-2475006	DRIVEWAY, P.C. CONCRETE, 6 IN.	395				395		395	\$8.00	\$3,160.00		\$3,160.00
48	2515-6745608	REMOVAL OF PAVED DRIVEWAY	128				128		128	\$32.00	\$4,096.00		\$4,096.00
49	2516-8625000	COMBINED CONCRETE SIDEWALK AND RETAINING WALL	35				35		35	\$6.50	\$227.50		\$227.50
50	2519-4200040	REMOVAL AND REINSTALLATION OF FENCE, FIELD	280				280		280	\$315.00	\$88,200.00		\$88,200.00
51	2528-2518000	SAFETY CLOSURE	3				3		3	\$32.50	\$97.50		\$97.50
52	2528-8445110	TRAFFIC CLOSURE	0.9				0.9		0.9	\$2,850.00	\$2,565.00		\$2,565.00
53	2533-4900005	MOBILIZATION	0.6				0.6		0.6	\$60.00	\$36.00		\$36.00
54	2532-0000210	TRENCH FOUNDATION	50				50		50	\$33.00	\$1,650.00		\$1,650.00
55	2532-0000300	TRENCH COMPACTION TESTING	0.5				0.5		0.5	\$7,500.00	\$3,750.00		\$3,750.00
56	2534-0110008	WATER MAIN, TRENCHED, POLYVINYL CHLORIDE PIPE (PVC), 8 IN.	40				40		40	\$66.48	\$2,659.20		\$2,659.20
57	2534-0110122	WATER MAIN, TRENCHED, POLYVINYL CHLORIDE PIPE (PVC), 12 IN.	22				22		22	\$114.94	\$2,528.68		\$2,528.68
58	2534-0204120	WATER SERVICE STUB, COPPER, 2 IN.	253				253		253	\$61.00	\$15,513.00		\$15,513.00
59	2534-0205110	WATER SERVICE STUB, COPPER, 1 IN.	253				253		253	\$61.00	\$15,513.00		\$15,513.00
60	2534-0205140	WATER SERVICE CORPORATION, COPPER, 1 IN.	5				5		5	\$350.00	\$1,750.00		\$1,750.00
61	2534-0207001	VALVE, GATE, DIP, 8 IN.	2				2		2	\$2,400.00	\$4,800.00		\$4,800.00
62	2534-0207012	VALVE, GATE, DIP, 12 IN.	6				6		6	\$5,320.00	\$31,920.00		\$31,920.00
63	2534-0210201	FIRE HYDRANT ASSEMBLY, MK-201	0				0		0	\$1,010.00	\$0.00		\$0.00
64	2539-9999003	( 'CUBIC YARDS' ITEM) MEDIAN LANDSCAPE CONCRETE	1				1		1	\$2,050.00	\$2,050.00		\$2,050.00
65	2539-9999005	( 'EACH' ITEM) ASPHALT 4 IN.	1				1		1	\$3,560.00	\$3,560.00		\$3,560.00
66	2539-9999005	( 'EACH' ITEM) ASPHALT 6 IN.	1				1		1	\$3,560.00	\$3,560.00		\$3,560.00
67	2539-9999005	( 'EACH' ITEM) REMOVAL OF EXISTING HYDRANT ASSEMBLY	1				1		1	\$150.00	\$150.00		\$150.00
68	2539-9999005	( 'EACH' ITEM) WATER MAIN CONNECTIONS	3				3		3	\$1,070.00	\$3,210.00		\$3,210.00
69	2539-9999009	( 'LINEAR FEET' ITEM) REPAIR DAMAGED TILE 4 IN. OR 6 IN.	100				100		100	\$20.00	\$2,000.00		\$2,000.00
70	2539-9999009	( 'LINEAR FEET' ITEM) REPAIR DAMAGED TILE 4 IN. OR 6 IN.	150				150		150	\$20.00	\$3,000.00		\$3,000.00
71	2539-9999010	( 'LUMP SUM' ITEM) MAINTENANCE OF SOLID WASTE COLLECTION	5				5		5	\$4,000.00	\$20,000.00		\$20,000.00
72	2539-9999020	( 'TONS' ITEM) TEMPORARY GRANULAR SURFACING	500				500		500	\$15.00	\$7,500.00		\$7,500.00
73	2601-2636043	SEEDING AND FERTILIZING (SUBAL)	1				1		1	\$380.00	\$380.00		\$380.00
74	2601-2636043	SEEDING AND FERTILIZING (SUBAL)	6				6		6	\$22.00	\$132.00		\$132.00
75	2602-0000044	PERIMETER AND SLOPE SEDIMENT CONTROL DEVICE, 9 IN. DIA.	5				5		5	\$1,000.00	\$5,000.00		\$5,000.00
76	2602-0000051	REMOVAL OF PERIMETER AND SLOPE OR DITCH CHECK SEDIMENT CONTROL DEVICE	868				868		868	\$2.28	\$1,959.84		\$1,959.84
77	2602-0010101	MOBILIZATION, EROSION CONTROL	3000				3000		3000	\$5.50	\$16,500.00		\$16,500.00
78	2602-0010101	MOBILIZATION, EROSION CONTROL	5				5		5	\$500.00	\$2,500.00		\$2,500.00

Pay Application No. 12  
West Buchanan Street Paving & Reconstruction  
Washington, Iowa

Belong Construction, Inc.

Project Number	STBE-SWAP-8340(612)-S6-92	Location	Existing	Proposed	Quantity	Unit	Rate	Total	
CON2		Locals Existing Tile	1.00		2.00		\$308.00	\$1,000.00	
CON2		Hydrobase Interlock	1.00		1.00		\$3,600.00	\$3,600.00	
CON2		Temp Field Fence	1.00		1.00		\$1,500.00	\$1,500.00	
CON2		Thickness Interleave 7"	1.00		1.00		\$7,659.08	\$7,659.08	
CON2		Thickness Interleave 8"	1.00		1.00		\$8,674.26	\$8,674.26	
<b>Totals</b>								<b>\$1,995,124.74</b>	<b>\$1,716,832.54</b>

Category	Amount	Notes
Total Completed to Date	\$1,395,124.74	
Amount Retained @ 5% (Max. \$30,000)	\$24,378.47	
Total Due Contractor	\$1,370,746.27	
Less Previous Payments	\$1,354,824.41	
Amount Due Contractor this Application	\$16,721.86	
IDOT Withholding SX	\$836.09	
City Share This Application	\$15,885.77	
<b>Total Available for Payment</b>	<b>\$15,777.34</b>	

Category	Amount	Notes
Eligible Amount	\$1,370,746.27	(Div. 1)
IDOT Withholding SX	\$68,597.31	
Subtotal This Request	\$1,302,148.96	
Less Previously Reimbursed	\$1,286,323.19	
Amount to be Reimbursed this Application	\$15,825.77	

# Doc Express® Document Signing History

Contract: 92-8140-612 Document: Pay Request 12

This document is in the process of being signed by all required signatories using the Doc Express® service. Following are the signatures that have occurred so far.

Date	Signed By
04/29/2023	Jack Pope Garden & Associates LTD Electronic Signature (Recommended by Engineer)
	(Approved by PIRC (when applicable))

**Contractor's Application for Payment**

Owner:	City of Washington	Owner's Project No.:	
Engineer:	FOX Strand	Engineer's Project No.:	3424-20B
Contractor:	Cornerstone Excavating, Inc.	Contractor's Project No.:	
Project:	2022 Washington Water Main Improvements		
Contract:	2022 Washington Water Main Improvements		
Application No.:	1	Application Date:	5/4/2023
Application Period:	From 4/1/2023	to	4/30/2023

1. Original Contract Price	\$	3,668,641.25
2. Net change by Change Orders	\$	(570,307.55)
3. Current Contract Price (Line 1 + Line 2)	\$	3,098,333.70
4. Total Work completed and materials stored to date (Sum of Column G Lump Sum Total and Column J Unit Price Total)	\$	153,270.00
5. Retainage		
a. 5% X \$ 153,270.00 Work Completed	\$	7,663.50
b. 0% X \$ - Stored Materials	\$	-
c. Total Retainage (Line 5.a + Line 5.b)	\$	7,663.50
6. Amount eligible to date (Line 4 - Line 5.c)	\$	145,606.50
7. Less previous payments (Line 6 from prior application)		
8. Amount due this application	\$	145,606.50
9. Balance to finish, including retainage (Line 3 - Line 6)	\$	2,952,727.20

**Contractor's Certification**

The undersigned Contractor certifies, to the best of its knowledge, the following:

(1) All previous progress payments received from Owner on account of Work done under the Contract have been applied on account to discharge Contractor's legitimate obligations incurred in connection with the Work covered by prior Applications for Payment;

(2) Title to all Work, materials and equipment incorporated in said Work, or otherwise listed in or covered by this Application for Payment, will pass to Owner at time of payment free and clear of all liens, security interests, and encumbrances (except such as are covered by a bond acceptable to Owner indemnifying Owner against any such liens, security interest, or encumbrances); and

(3) All the Work covered by this Application for Payment is in accordance with the Contract Documents and is not defective.

Contractor: BJ Miller

Signature:  Date: 5/11/23

<b>Recommended by Engineer</b>		<b>Approved by Owner</b>	
By:		By:	
Title:	Project Manager	Title:	
Date:	5/12/2023	Date:	
<b>Approved by Funding Agency</b>			
By:		By:	
Title:		Title:	
Date:		Date:	

Progress Estimate - Unit Price Work

Contractor's Application for Payment

Owner:	City of Washington	Owner's Project No.:	
Engineer:	FOX Strand	Engineer's Project No.:	3424-208
Contractor:	Conroy/Long Excavating, Inc.	Contractor's Project No.:	
Project:	2022 Washington Water Main Improvements		
Contract:	2022 Washington Water Main Improvements		

Application No.:	1	Application Period:	From 04/01/23 to 04/30/23	Application Date:	05/04/23
------------------	---	---------------------	---------------------------	-------------------	----------

A	B	C	D		E		F		G	H	I	J
			Contract Information	Work Completed	Contract Information	Work Completed	Contract Information	Work Completed				
Bid Item No.	Description	Item Quantity	Units	Unit Price (\$)	Value of Bid Item (C X E)	Estimated Quantity Incorporated in the Work	Value of Work Completed to Date (E X G)	Materials Currently Stored (not in D)	Work Completed and Material Stored to Date (H X I)	% of Value of Item (J / F)	Balance to Finish (F - J)	
Original Contract												
Division 1 - General												
1.01	Compaction Testing	1	LS	\$ 7,500.00	7,500.00					0%	7,500.00	
1.02	Construction Contingency (Allowance)	1	ALW	\$ 20,000.00	20,000.00					0%	20,000.00	
1.03	Temporary Malloes Cluster	1	LS	\$ 975.00	975.00					0%	975.00	
1.04	Removals, Miscellaneous	1	LS	\$ 14,750.00	14,750.00					0%	14,750.00	
1.05	Remove And Replace Signage	1	LS	\$ 9,750.00	9,750.00					0%	9,750.00	
Division 2 - Earthwork												
2.01	Topsoil, Sino, Blockfill, Finish, And Resprand	1	LS	\$ 34,550.00	34,550.00	0.10	3,455.00		3,455.00	10%	31,095.00	
2.02	Unsuitable Soils, Removal And Replacement	90	CY	\$ 20.00	2,500.00					0%	2,500.00	
2.03	Cleaning And Grubbing, Tree Removal, Tree Trimming	1	LS	\$ 34,950.00	34,950.00					0%	34,950.00	
Division 3 - Trench and Trenchless Construction												
3.01	Trench Foundation	50	TGN	\$ 56.00	2,750.00					0%	2,750.00	
3.02	Replacement Of Unavailable Sackfill, Trench	90	CY	\$ 25.00	2,500.00					0%	2,500.00	
Division 4 - Sewers and Drains												
4.01	CCTV 8-Inch Sanitary Sewer, Pre Construction Service Locate	2,349	LF	\$ 7.76	18,181.50					0%	18,181.50	
4.02	CCTV 16-Inch Sanitary Sewer, Pre Construction Service Locate	749	LF	\$ 7.76	5,781.50					0%	5,781.50	
4.03	CCTV 12-Inch Sanitary Sewer, Pre Construction Service Locate	10	LF	\$ 62.80	628.00					0%	628.00	
4.04	CCTV 4-Inch Sanitary Sewer W/Report, Post Construction Service Inspection	866	LF	\$ 7.76	7,401.25					0%	7,401.25	
4.05	CCTV 6-Inch Sanitary Sewer W/Report, Post Construction Service Inspection	332	LF	\$ 7.76	6,448.00					0%	6,448.00	
4.06	CCTV Inspection Reversal	6	EA	\$ 356.00	2,175.00					0%	2,175.00	
4.07	Sanitary Sewer Main Line, Heavy Cleaning	10	LR	\$ 326.00	3,250.00					0%	3,250.00	
4.08	Sanitary Sewer Main Line, Removal Of Heavy Roots	10	LR	\$ 326.00	3,250.00					0%	3,250.00	
4.09	Sanitary Sewer Main Line, Removal Of Heavy Scale	10	LR	\$ 326.00	3,250.00					0%	3,250.00	
4.10	Sanitary Sewer Main Line, Inducting Tap Cut	10	EA	\$ 1,200.00	12,000.00					0%	12,000.00	
4.11	Sanitary Sewer Dabits Chasing Removal	10	LR	\$ 425.00	4,250.00					0%	4,250.00	
4.12	Remove & Replace Sanitary Sewer	20	EA	\$ 4,216.00	85,500.00	2.00	8,550.00		8,550.00	10%	76,950.00	
Division 5 - Water Main and Appurtenances												
5.01	Cmp Existing Water Main In Place	19	EA	\$ 2,300.00	43,700.00					0%	43,700.00	
5.02	Removal Of Existing Water Main	30	LF	\$ 27.65	825.00					0%	825.00	
5.03	Remove And Salvage Existing Fire Hydrant	8	EA	\$ 1,784.00	14,000.00	1.00	1,750.00		1,750.00	13%	12,250.00	
5.04	Water Main, Connect To Existing, E. Main St. And N. 12TH Ave, Connection 1	1	LS	\$ 5,950.00	5,950.00					0%	5,950.00	
5.05	Water Main, Connect To Existing, E. Main St. And N. 12TH Ave, Connection 2	1	LS	\$ 6,550.00	6,550.00					0%	6,550.00	
5.06	Water Main, Connect To Existing, E. Main St. And N. 14TH Ave.	1	LS	\$ 15,025.00	15,025.00	1.00	15,025.00		15,025.00	100%		
5.07	Water Main, Connect To Existing, E. Main St. And N. 16TH Ave.	1	LS	\$ 6,880.00	6,880.00					0%	6,880.00	
5.08	Water Main, Connect To Existing, W. Madison St. And E. H Ave.	1	LS	\$ 8,400.00	8,400.00					0%	8,400.00	
5.09	Water Main, Connect To Existing, W. Madison St.	1	LS	\$ 3,835.00	3,835.00					0%	3,835.00	
5.10	Water Main, Connect To Existing, W. Madison St. And S. G Ave.	1	LS	\$ 9,835.00	9,835.00					0%	9,835.00	
5.11	Water Main, Connect To Existing, W. Madison St. And S. F Ave.	1	LS	\$ 14,750.00	14,750.00					0%	14,750.00	
5.12	Water Main, Connect To Existing, W. Madison St. And S. D Ave.	1	LS	\$ 8,800.00	8,800.00					0%	8,800.00	
5.13	Water Main, Connect To Existing, W. Madison St. And S. C Ave.	1	LS	\$ 5,600.00	5,600.00					0%	5,600.00	
5.14	Tapping Valve Assembly, 4"X4"	2	EA	\$ 4,750.00	9,500.00					0%	9,500.00	
5.15	Tapping Valve Assembly, 6"X6"	1	EA	\$ 11,750.00	11,750.00					0%	11,750.00	
5.16	Tapping Valve Assembly, 12"X6"	1	EA	\$ 8,930.00	8,930.00					0%	8,930.00	

Progress Estimate - Unit Price Work

Contractor's Application for Payment

Owner: City of Washington  
 Engineer: FOX Strand  
 Contractor: Cornerstone Excavating, Inc.  
 Project: 2022 Washington Water Main Improvements  
 Contract: 2022 Washington Water Main Improvements

Owner's Project No.:  
 Engineer's Project No.: 3424-208  
 Contractor's Project No.:

Application No.: 1 Application Period: From 04/01/23 to 04/30/23 Application Date: 05/04/23

A Bid Item No.	B Description	C Item Quantity	D Contract Information			E Work Completed			I Materials Currently Stored (not in G)	J Work Completed and Materials Stored to Date (H + I)	K % of Value of Item (J / E)	L Balance to Finish (E - J)
			F Units	G Unit Price (\$)	H Value of Bid Item (C X E)	I Estimated Quantity Incorporated in the Work	J Value of Work Completed to Date (E X G)					
5.17	Topping Valve Assembly, 12" X 8"	4	EA	\$ 11,025.00	44,100.00	2.00	22,050.00		22,050.00	50%	22,050.00	
5.18	Water Main, 8-inch, Case 1, Trenched	100	LF	\$ 79.00	7,900.00					0%	7,900.00	
5.19	Water Main, 8-inch, Case 1, Trenched, Restrained Joint	232	LF	\$ 90.00	20,880.00					0%	20,880.00	
5.20	Water Main, 8-inch, Case 1, Trenched DI, Nitrile Gaskets	1,160	LF	\$ 92.50	106,375.00					0%	106,375.00	
5.21	Water Main, 8-inch, Case 2, Trenchless DI, Nitrile Gaskets, Restrained Joint	245	LF	\$ 127.50	31,237.50					0%	31,237.50	
5.22	Water Main, 8-inch, Case 2, Trenchless PVC Or DI	100	LF	\$ 170.00	17,000.00					0%	17,000.00	
5.23	Water Main, 8-inch, Case 2, Trenchless DI, Nitrile Gaskets	1,180	LF	\$ 207.00	240,120.00					0%	240,120.00	
5.24	Water Main, 8-inch, Case 3, Trenchless Or Trenchless	670	LF	\$ 170.00	117,250.00	375.00	65,625.00		65,625.00	56%	51,625.00	
5.25	Water Main Service, 1-inch Horizontal, Connection To Existing	53	EA	\$ 876.00	46,375.00					0%	46,375.00	
5.26	Water Main Service Pipe, Trenched, 1-inch Copper	208	LF	\$ 49.60	10,296.00					0%	10,296.00	
5.27	Water Main Service Pipe Trenchless, 1-inch Copper	1,057	LF	\$ 56.00	109,592.00					0%	109,592.00	
5.28	Temporary Water Main Service (Contingency)	200	LF	\$ 43.00	8,600.00					0%	8,600.00	
5.29	Water Service Corporation	53	EA	\$ 400.00	21,200.00					0%	21,200.00	
5.30	Water Service Curb Stop And Box	53	EA	\$ 516.00	27,295.00					0%	27,295.00	
5.31	Water Main Service Pipe, Abandon Existing	33	EA	\$ 525.00	17,225.00					0%	17,225.00	
5.32	Fire Hydrant Assembly	10	EA	\$ 8,540.00	85,400.00	1.00	8,540.00		8,540.00	10%	76,860.00	
5.33	Water Main, 4-inch Resilient Wedge Gate Valve	1	EA	\$ 1,850.00	1,850.00					0%	1,850.00	
5.34	Water Main, 6-inch Resilient Wedge Gate Valve	1	EA	\$ 2,300.00	2,300.00					0%	2,300.00	
5.35	Water Main, 8-inch Resilient Wedge Gate Valve	1	EA	\$ 3,005.00	3,005.00	1.00	3,005.00		3,005.00	10%	2,040.00	
5.36	Water Main, 12-inch Resilient Wedge Gate Valve	1	EA	\$ 4,995.00	4,995.00					0%	4,995.00	
5.37	Remove Existing Water Main Valve	14	EA	\$ 625.00	8,750.00					0%	8,750.00	
5.38	Abandon Existing Water Main Valve In Place	1	EA	\$ 5,200.00	5,200.00					0%	5,200.00	
5.39	Water Main Testing And Disinfection	1	LS	\$ 12,500.00	12,500.00					0%	12,500.00	
5.40	Water Main Disconnections	1	LS	\$ 23,550.00	23,550.00					0%	23,550.00	
5.41	Abandon Existing Water Main In Place, W/ Guard	10	LF	\$ 225.00	2,250.00					0%	2,250.00	
Division 5 - Structures for Sanitary and Storm Sewers												
5.01	Remove Existing Storm Sewer Intake	2	EA	\$ 2,600.00	5,600.00					0%	5,600.00	
5.02	Storm Sewer Intake, SW-501	2	EA	\$ 7,100.00	14,300.00					0%	14,300.00	
Division 7 - Pavement and Appurtenances												
7.01	Sidewalk Removal And Disposal	676	SY	\$ 11.50	7,764.00					0%	7,764.00	
7.02	PCC Sidewalk, 8-inch	1,122	SY	\$ 90.00	100,980.00					0%	100,980.00	
7.03	Pavement Removal And Disposal	1,813	SY	\$ 16.00	22,695.00	100.00	1,500.00		1,500.00	7%	21,195.00	
7.04	Removal Of Curb And Gutter	1,846	LF	\$ 15.00	15,675.00					0%	15,675.00	
7.05	PCC Full Depth Patch	1,320	SY	\$ 178.00	235,000.00					0%	235,000.00	
7.06	PCC Curb And Gutter, 30-inch	668	LF	\$ 78.00	72,450.00					0%	72,450.00	
7.07	PCC Pavement Samples And Testing	1	LS	\$ 9,765.00	9,765.00					10%	9,765.00	
7.08	Detectable Warning Panels	332	SF	\$ 76.00	24,900.00					0%	24,900.00	
7.09	Asa Survey	21	EA	\$ 380.00	7,950.00					0%	7,950.00	
7.10	Driveway Pavement Removal And Disposal	449	SY	\$ 16.00	6,735.00					0%	6,735.00	
7.11	PCC Commercial Driveway Pavement, 7.5-inch	191	SY	\$ 175.00	33,425.00					0%	33,425.00	
7.12	PCC Residential Driveway Pavement, 6-inch	281	SY	\$ 160.00	39,150.00					0%	39,150.00	
7.13	Painted Pavement Markings	1	LS	\$ 9,875.00	9,875.00					0%	9,875.00	
7.14	Removable Bollard	4	EA	\$ 5,225.00	20,900.00					0%	20,900.00	
Division 8 - Traffic Control												



Progress Estimate - Unit Price Work

Contractor's Application for Payment

Owner: City of Washington  
 Engineer: FOX Strand  
 Contractor: Cornerstone Excavating, Inc.  
 Project: 2022 Washington Water Main Improvements  
 Contract: 2022 Washington Water Main Improvements

Owner's Project No.:  
 Engineer's Project No.: 3424-20B  
 Contractor's Project No.:

Application No.: 1 Application Period: From 04/01/23 to 04/30/23 Application Date: 05/04/23

A Bid Item No.	B Description	C Item Quantity	D Units	E Contract Information		G Work Completed			H Value of Work Completed to Date (E X G)	I Materials Currently Stored (Not In G)	J Work Completed and Materials Stored to Date (H + I)	K % of Value of Item (J / E)	L Balance to Finish (E - J)
				F Unit Price (\$)	F Value of Bid Item (C X E) (\$)	F Estimated Quantity Incorporated in the Work	F Value of Work Completed to Date (E X G) (\$)	F Materials Currently Stored (Not In G) (\$)					
8.01	Traffic Control & Staging	1	LS	\$ 15,300.00	15,300.00	0.25	3,825.00		3,825.00	25%	11,475.00		
Division 9 - Site Work													
9.01	Hydraulic Seeding, Fertilizing, And Mulching - Type 1	13	AC	\$ 10,260.00	13,325.00					0%	13,325.00		
9.02	Filter Sock	600	LF	\$ 7.00	3,500.00	10.00	70.00		70.00	2%	3,430.00		
9.03	Inlet Protection, Drop-In	14	EA	\$ 165.00	2,590.00					0%	2,590.00		
Division 11 - Miscellaneous													
11.01	Mobilization	1	LB	\$ 198,750.00	198,750.00	0.10	19,875.00		19,875.00	10%	178,875.00		
11.02	Exploratory Digging	1	LB	\$ 34,585.00	34,585.00					0%	34,585.00		
11.03	Maintenance Of Solid Waste Collection	1	LB	\$ 9,850.00	9,850.00					0%	9,850.00		
Division 12 - Washington Blvd. (REMOVED BY CO NO. 1)													
12.01	Cap Existing Water Main In Place	7	EA	\$ 1,686.00	11,760.00					0%	11,760.00		
12.02	Tapping Valve Assembly, 4"K"	2	EA	\$ 5,160.00	10,300.00					0%	10,300.00		
12.03	Tapping Valve Assembly, 12"K"	2	EA	\$ 10,076.00	20,150.00					0%	20,150.00		
12.04	Water Main, 8-Inch, Class 2, Trenchless PVC Or DI	840	LF	\$ 220.96	186,560.00					0%	186,560.00		
12.05	Water Main Service, 1-Inch Hardware, Connection To Existing	18	EA	\$ 490.00	8,820.00					0%	8,820.00		
12.06	Water Main Service Pipe Trenchless, 1-Inch Copper	669	LF	\$ 80.00	69,520.00					0%	69,520.00		
12.07	Water Main Service Pipe Trenchless, 1-Inch Copper	30	LF	\$ 57.00	1,710.00					0%	1,710.00		
12.08	Water Service Curb Stop & Box	18	EA	\$ 475.00	8,550.00					0%	8,550.00		
12.09	Water Main Service Pipe, Abandon Existing	10	EA	\$ 375.00	6,750.00					0%	6,750.00		
12.10	Fire Hydrant Assembly	1	EA	\$ 8,540.00	8,540.00					0%	8,540.00		
12.11	Water Main, 6-Inch Resilient Wedge Gate Valve	2	EA	\$ 3,600.00	7,200.00					0%	7,200.00		
12.12	Skewch, Removal And Disposal	114	SY	\$ 14.50	1,653.00					0%	1,653.00		
12.13	POC Sidewalk, 8-Inch	116	SY	\$ 300.00	34,500.00					0%	34,500.00		
12.14	Pavement Removal And Disposal	184	SY	\$ 14.50	2,668.00					0%	2,668.00		
12.15	Brick Paver Removal And Salvage	26	SY	\$ 325.00	8,455.00					0%	8,455.00		
12.16	Removal Of Curb And Gutter	40	LF	\$ 37.50	1,500.00					0%	1,500.00		
12.17	Driveway Pavement Removal And Disposal	26	SY	\$ 22.00	570.00					0%	570.00		
12.18	POC Full Depth Patch	126	SY	\$ 175.00	22,050.00					0%	22,050.00		
12.19	POC Curb And Gutter, 30-Inch	40	LF	\$ 75.00	3,000.00					0%	3,000.00		
12.20	Brick Paver Patch, Restoration Of Existing Pavers	65	SY	\$ 223.00	14,395.00					0%	14,395.00		
12.21	POC Residential Driveway Pavement, 6-Inch	26	SY	\$ 180.00	4,680.00					0%	4,680.00		
12.22	Hydraulic Seeding, Fertilizing, And Mulching - Type 1	650	AC	\$ 3,750.00	4,250.00					0%	4,250.00		
12.23	Compaction Testing	1	LS	\$ 6,225.00	6,225.00					0%	6,225.00		
12.24	Removals, Miscellaneous	1	LS	\$ 10,250.00	10,250.00					0%	10,250.00		
12.25	Remove And Replace Signs	1	LS	\$ 4,585.00	4,585.00					0%	4,585.00		
12.26	Dispose, Slugs, Stockpile, Fertilizer, And Respread	1	LS	\$ 12,500.00	12,500.00					0%	12,500.00		
12.27	Clearing And Grubbing, Tree Removal, Tree Trimming	1	LS	\$ 7,500.00	7,500.00					0%	7,500.00		
12.28	Water Main, Connect To Existing, W. Washington Blvd And B. F. Ave.	1	LS	\$ 10,500.00	10,500.00					0%	10,500.00		
12.29	Water Main, Connect To Existing, W. Washington Blvd And B. D. Ave.	1	LS	\$ 10,500.00	10,500.00					0%	10,500.00		
12.30	Pot Pavement Samples And Testing	1	LS	\$ 5,500.00	5,500.00					0%	5,500.00		
12.31	Traffic Control & Staging	1	LS	\$ 5,500.00	5,500.00					0%	5,500.00		
12.32	Mobilization	1	LS	\$ 25,500.00	25,500.00					0%	25,500.00		
12.33	Exploratory Digging	1	LS	\$ 7,850.00	7,850.00					0%	7,850.00		
12.34	Water Main Testing And Disinfection	1	LS	\$ 5,500.00	5,500.00					0%	5,500.00		

Progress Estimate - Unit Price Work

Contractor's Application for Payment

Owner: City of Washington  
 Engineer: FOX Strand  
 Contractor: Cornerstone Excavating, Inc.  
 Project: 2022 Washington Water Main Improvements  
 Contract: 2022 Washington Water Main Improvements

Owner's Project No.:  
 Engineer's Project No.: 3424-20B  
 Contractor's Project No.:

Application No.:		Application Period:		From:	to:	Application Date:					
1		From 04/01/23 to 04/30/23		05/04/23							
Bid Item No.	Description	Item Quantity	Units	Unit Price (\$)	Value of Bid Item (C x E) (\$)	Work Completed		Materials Currently Stored (not in G) (\$)	Work Completed and Materials Stored to Date (H + I) (\$)	% of Value of Item (J / F)	Balance to Finish (F - J) (\$)
						Estimated Quantity Incorporated in the Work (G)	Value of Work Completed to Date (G x E) (\$)				
12.35	Water Main Disconnections	1	LS	4,865.00	4,865.00					0%	4,865.00
12.36	Water Main Casing With Watertight End Seals, Dip, 8-Inch Division 13 - Bike Trail	20	LF	315.00	6,300.00					0%	6,300.00
13.01	PCC Bike Trail, 6.5-Inch	734	SY	80.00	58,720.00					0%	58,720.00
13.02	ADA Survey	4	EA	350.00	1,400.00					0%	1,400.00
13.03	Detectable Warning Panels	95	SF	75.00	7,125.00					0%	7,125.00
Bid Alternate No. 1											
A1.01	Compaction Testing	1	LS	7,750.00	7,750.00					0%	7,750.00
A1.02	Removals, Miscellaneous	1	LS	10,350.00	10,350.00					0%	10,350.00
A1.03	Remove And Replace Signage	1	LS	5,500.00	5,500.00					0%	5,500.00
A1.04	CCTV 8-Inch Sanitary Sewer, Pre Construction Service Locate	870	LF	2.26	7,177.50					0%	7,177.50
A1.05	CCTV 4-Inch Sanitary Sewer W/Report, Post Construction Service Inspection	316	LF	8.25	2,598.75					0%	2,598.75
A1.06	CCTV 8-Inch Sanitary Sewer W/Report, Post Construction Service Inspection	316	LF	8.25	2,598.75					0%	2,598.75
A1.07	CCTV Inspection Reversal	3	EA	540.00	1,620.00					0%	1,620.00
A1.08	Sanitary Sewer Main Line, Heavy Cleaning	10	HR	355.00	3,550.00					0%	3,550.00
A1.09	Sanitary Sewer Main Line, Removal Of Heavy Roots	10	HR	325.00	3,250.00					0%	3,250.00
A1.10	Sanitary Sewer Main Line, Removal Of Heavy Scale	10	HR	325.00	3,250.00					0%	3,250.00
A1.11	Sanitary Sewer Main Line, Pre-Excavating Tap Out	10	EA	1,200.00	12,000.00					0%	12,000.00
A1.12	Sanitary Sewer Deposits Cutting Removal	10	HR	425.00	4,250.00					0%	4,250.00
A1.13	Cop Existing Water Main In Place	2	EA	1,900.00	3,800.00					0%	3,800.00
A1.14	Removal Of Existing Water Main	20	LF	47.50	950.00					0%	950.00
A1.15	Removal Of Existing Water Main Valve	3	EA	2,200.00	6,600.00					0%	6,600.00
A1.16	Remove And Salvage Existing Fire Hydrant	2	EA	1,700.00	3,400.00					0%	3,400.00
A1.17	Water Main, Connect To Existing, W. Madison St. And Hwy 1	1	LS	4,500.00	4,500.00					0%	4,500.00
A1.18	Water Main, Connect To Existing, W. Madison St. And S. H Ave.	1	LS	9,755.00	9,755.00					0%	9,755.00
A1.19	Tapping Valve Assembly, 12" Ø	1	EA	10,475.00	10,475.00					0%	10,475.00
A1.20	Water Main, Installation Case 1, Trenches Di W/Nitile Gaskets	30	LF	81.80	2,454.00					0%	2,454.00
A1.21	Water Main, Installation Case 2, Trenches Di W/Nitile Gaskets	1,348	LF	93.26	133,789.00					0%	133,789.00
A1.22	Water Main, Installation Case 3, Trenches Di W/Nitile Gaskets	10	LF	115.00	1,150.00					0%	1,150.00
A1.23	Water Main Service, 1-Inch Firehydrant, Connection To Existing	19	EA	715.00	13,585.00					0%	13,585.00
A1.24	Water Main Service Pipe, Trenched, 1-Inch Copper	84	LF	45.50	4,158.00					0%	4,158.00
A1.25	Water Main Service Pipe, Trenchless, 1-Inch Copper	618	LF	54.50	33,517.50					0%	33,517.50
A1.26	Temporary Water Main Service, Contingency	106	LF	43.00	4,558.00					0%	4,558.00
A1.27	Water Service Corporation	19	EA	328.00	6,175.00					0%	6,175.00
A1.28	Water Service Curb Stop And Box	10	EA	375.00	3,750.00					0%	3,750.00
A1.29	Water Main Service Pipe, Abandon Existing	19	EA	328.00	6,175.00					0%	6,175.00
A1.30	Pipe Hydrant Assembly	6	EA	9,300.00	57,300.00					0%	57,300.00
A1.31	Water Main, 8-Inch Resilient Wedge Gate Valve	1	EA	2,950.00	2,950.00					0%	2,950.00
A1.32	Abandon Existing Water Main Valve In Place	2	EA	1,160.00	2,320.00					0%	2,320.00
A1.33	Water Main Testing And Disinfection	1	LS	7,065.00	7,065.00					0%	7,065.00
A1.34	Water Main Disconnections	1	LS	10,700.00	10,700.00					0%	10,700.00
A1.35	Sidewalk Removal And Disposal	87	SY	30.00	2,610.00					0%	2,610.00
A1.36	PCC Sidewalk, 6-Inch	293	SY	300.00	87,900.00					0%	87,900.00
A1.37	Pavement Removal And Disposal	83	SY	30.00	2,490.00					0%	2,490.00

Unit Price

Progress Estimate - Unit Price Work

Contractor's Application for Payment

Owner: City of Washington  
 Engineer: FOX Standa  
 Contractor: Cornerstone Excavating, Inc.  
 Project: 2022 Washington Water Main Improvements  
 Contract: 2022 Washington Water Main Improvements

Owner's Project No.:  
 Engineer's Project No.: 3424-206  
 Contractor's Project No.:

Application No. 1		Application Period: From 04/01/23 to 04/30/23		Application Date: 05/04/23							
A Bid Item No.	B Description	C Contract Information				D Work Completed					
		E Item Quantity	F Units	G Unit Price (\$)	H Value of Bid Item (C x E) (\$)	I Estimated Quantity Incorporated in the Work	J Value of Work Completed to Date (E x G) (\$)	K Materials Currently Stored (not in G) (\$)	L Work Completed and Materials Stored to Date (I + J) (\$)	M % of Value of Item (L / H) (%)	N Balance to Finish (H - L) (\$)
A1.38	Removal Of Curb And Gutter	81	LF	\$ 27.50	2,227.50					0%	2,227.50
A1.39	PCC Full Depth Patch	89	SY	\$ 450.00	27,600.00					0%	27,600.00
A1.40	PCC Curb And Gutter, 30-Inch	81	LF	\$ 75.00	6,075.00					0%	6,075.00
A1.41	PCC Pavement Samples And Testing	1	LS	\$ 6,500.00	6,500.00					0%	6,500.00
A1.42	Detachable Warning Panels	1	RP	\$ 75.00	75.00					0%	75.00
A1.43	ADA Survey	1	EA	\$ 350.00	350.00					0%	350.00
A1.44	Driveway Pavement Removal And Disposal	159	SY	\$ 30.00	4,740.00					0%	4,740.00
A1.45	PCC Commercial Driveway Pavement, 7.5-Inch	136	SY	\$ 176.00	24,150.00					0%	24,150.00
A1.46	PCC Residential Driveway Pavement, 6-Inch	3	SY	\$ 1,500.00	4,500.00					0%	4,500.00
A1.47	Traffic Control & Staging	1	LS	\$ 11,500.00	11,500.00					0%	11,500.00
A1.48	Hydraulic Seeding, Fertilizing, And Mulching - Type 1	6.80	AG	\$ 10,000.00	3,000.00					0%	3,000.00
A1.49	Filter Bock	100	LF	\$ 7.00	700.00					0%	700.00
A1.50	Inlet Protection, Drop-In	6	EA	\$ 155.00	925.00					0%	925.00
A1.51	Mobilization	1	LS	\$ 19,850.00	19,850.00					0%	19,850.00
A1.52	Exploratory Digging	1	LS	\$ 5,250.00	5,250.00					0%	5,250.00
A1.63	Abandon Existing Water Main In Place, W/ Grout	1,189	LF	\$ 30.00	35,850.00					0%	35,850.00
<b>Original Contract Totals</b>					<b>\$ 3,668,641.25</b>	<b>\$ 193,270.00</b>	<b>\$</b>	<b>\$ 193,270.00</b>	<b>0%</b>	<b>\$ 3,515,371.25</b>	

Progress Estimate - Unit Price Work

Contractor's Application for Payment

Owner: City of Washington  
 Engineer: FOX Strand  
 Contractor: Cornerstone Excavating, Inc.  
 Project: 2022 Washington Water Main Improvements  
 Contract: 2022 Washington Water Main Improvements

Owner's Project No.: \_\_\_\_\_  
 Engineer's Project No.: 3424-20B  
 Contractor's Project No.: \_\_\_\_\_

Application No.:		Application Period:		From	to	Application Date:					
1				04/01/23	04/30/23	05/04/23					
A	B	C	D	E	F	G		H	I	J	
Bid Item No.	Description	Item Quantity	Units	Unit Price (\$)	Value of Bid Item (C X E)	Work Completed		Materials Currently Stored (in \$)	Work Completed and Materials Stored to Date (in \$)	% of Value of Item (I/J)	Balance to Finish (K)
						Estimated Quantity Incorporated in the Work	Value of Work Completed to Date (E X G)				
Change Orders											
CO 1.1	Remove Division 12 Items (See CO No. 1)	15		1.00	(559,426.00)					0%	(559,426.00)
CO 1.2	Remove Multi-Use Trail (CO No. 1)	5Y		(734.00)	80.00					0%	(58,720.00)
CO 1.3	Multi-Use Trail to 5' Sidewalk (CO No. 1)	5Y		367.00	130.35					0%	47,838.45
					<b>Change Order Totals</b>	\$ (870,307.55)				0%	\$ (570,307.55)
<b>Original Contract and Change Orders</b>											
						<b>Project Totals</b>	\$ 3,098,333.70	\$ 153,270.00	\$ 153,270.00	5%	\$ 2,945,063.70

*Millie Youngquist, Mayor Pro Tem  
Sally Hart, City Clerk  
Kevin Olson, City Attorney  
Deanna McCusker, City Administrator*



*City of Washington  
215 East Washington Street  
Washington, Iowa 52353  
(319) 653-6584 Phone  
(319) 653-5273 Fax*

---

May 10, 2023

To: Mayor & City Council  
Cc: Sally Hart, City Clerk  
Kelsey Brown, Finance Director

From: Deanna McCusker  
City Administrator

Re: Ordinance to Amend Utility Rates

The Council reviewed and discussed preliminarily approving the following utility rates during the budget process, which would begin on July 1, 2023, as presented in the attached ordinance and as follows:

Water: 9.5% increase on usage and base rate

Sewer: 5% increase on usage only, no change to base rate

Residential Water Utility Rates

City of Washington, IA  
Effective July 1, 2023

WET Tax 6%

	Old	New
Water Minimum Charge (9.5% Increase)	\$ 17.85	\$ 19.55
Water Usage (9.5% Increase)	\$ 4.99	\$ 5.46
Sewer Minimum Charge (No Increase)	\$ 31.50	\$ 31.50
Sewer Usage (5% Increase)	\$ 4.68	\$ 4.91

65-Gallon Garbage*	\$ 21.70	\$ 22.79
35-Gallon Garbage*	\$ 17.94	\$ 18.84
35-Gallon Biweekly*	\$ 14.20	\$ 14.92
Water Deposit	\$ 150.00	\$ 150.00

**NEW RATES**

Consumption in Cu. Ft	minimum	100	200	300	400	500	600	700	800	900	1000	1100	1200
Water	19.55	25.01	30.47	35.94	41.40	46.87	52.33	57.79	63.26	68.72	74.19	79.65	85.11
Sewer	31.50	36.41	41.33	46.24	51.16	56.07	60.98	65.90	70.81	75.73	80.64	85.55	90.47
Tax	1.17	1.50	1.83	2.16	2.48	2.81	3.14	3.47	3.80	4.12	4.45	4.78	5.11
65-Gallon Garbage	22.79	22.79	22.79	22.79	22.79	22.79	22.79	22.79	22.79	22.79	22.79	22.79	22.79
35-Gallon Garbage	18.84	18.84	18.84	18.84	18.84	18.84	18.84	18.84	18.84	18.84	18.84	18.84	18.84
35-Gallon Biweekly	14.92	14.92	14.92	14.92	14.92	14.92	14.92	14.92	14.92	14.92	14.92	14.92	14.92
Total w/ 65-gallon	75.00	85.71	96.42	107.12	117.83	128.53	139.24	149.94	160.65	171.36	182.06	192.77	203.47
Total w/35-gallon	71.06	81.76	92.47	103.17	113.88	124.58	135.29	146.00	156.70	167.41	178.11	188.82	199.53
Total w/35-gal biweekly	67.14	77.84	88.55	99.26	109.96	120.67	131.37	142.08	152.79	163.49	174.20	184.90	195.61

**OLD RATES**

Consumption In Cu. Ft	minimum	100	200	300	400	500	600	700	800	900	1000	1100	1200
Water	17.85	22.84	27.83	32.82	37.81	42.80	47.79	52.78	57.77	62.76	67.75	72.74	77.73
Sewer	31.50	36.18	40.86	45.54	50.22	54.90	59.58	64.26	68.94	73.62	78.30	82.98	87.66
Tax	1.07	1.37	1.67	1.97	2.27	2.57	2.87	3.17	3.47	3.77	4.07	4.36	4.66
65-Gallon Garbage	21.70	21.70	21.70	21.70	21.70	21.70	21.70	21.70	21.70	21.70	21.70	21.70	21.70
35-Gallon Garbage	17.94	17.94	17.94	17.94	17.94	17.94	17.94	17.94	17.94	17.94	17.94	17.94	17.94
35-Gallon Biweekly	14.20	14.20	14.20	14.20	14.20	14.20	14.20	14.20	14.20	14.20	14.20	14.20	14.20
Total w/ 65-gallon	72.12	82.09	92.06	102.03	112.00	121.97	131.94	141.91	151.88	161.85	171.82	181.78	191.75
Total w/35-gallon	68.36	78.33	88.30	98.27	108.24	118.21	128.18	138.15	148.12	158.09	168.06	178.02	187.99
Total w/35-gal biweekly	64.62	74.59	84.56	94.53	104.50	114.47	124.44	134.41	144.38	154.35	164.32	174.28	184.25
Change- w/ 65-gallon	2.88	3.62	4.36	5.09	5.83	6.56	7.30	8.04	8.77	9.51	10.25	10.98	11.72
Change- w/35-gallon	2.69	3.43	4.17	4.90	5.64	6.38	7.11	7.85	8.59	9.32	10.06	10.80	11.53
Change- w/35-gal biweekly	2.52	3.25	3.99	4.73	5.46	6.20	6.94	7.67	8.41	9.15	9.88	10.62	11.36

\* Garbage rates increase 5% per year through FY24 by adopted City Code without further Council action

ORDINANCE NO. \_\_\_\_\_

**AN ORDINANCE AMENDING CHAPTER 92, WATER RATES  
AND CHAPTER 99, SEWER USER CHARGE**

**BE IT ORDAINED** by the City Council of the City of Washington, Iowa:

**SECTION 1.** The Code of Ordinances of the City of Washington, Iowa, 2014, Section 92.02, titled, "Rates for Service", is hereby amended to read as follows by amending Section 92.02 (1) and (2):

**"92.02 RATES FOR SERVICE.** Water service shall be furnished at the following rates with the City:

1. Base Charge. There shall be a basic monthly water service charge of nineteen dollars and fifty-five cents (\$19.55) per account.
2. Usage Rates. Customers shall be charged for water usage in accordance with the following rate schedule:

*(Code of Iowa, Sec. 384.84[1])*

Cubic Feet Used Per Month	Rate
All Usage	\$5.46 per 100 cubic feet

”

**SECTION 2.** The Code of Ordinances of the City of Washington, Iowa, 2014, Section 99.01, titled, "Rates for Service", is hereby amended to read as follows by amending Section 99.01(1) and (2):

**"99.01 SEWER SERVICE CHARGES REQUIRED.** The monthly sewer use charge shall be in accordance with the following:

1. Non-Residential Customers.

A. For each water meter of every nonresidential property receiving municipal sewer service using 1,400 cubic feet or less of water, with or without a water meter, the charge shall be an amount equal to the sum of \$31.50 per month plus \$4.91 per 100 cubic feet of water used.

B. For each water meter of every nonresidential property receiving municipal sewer service using between 1,401 and 15,000 cubic feet of water, with or without a water meter, the charge shall be an amount equal to the sum of \$63.00 per month plus \$4.91 per 100 cubic feet of water used.

C. For each water meter of every nonresidential property receiving municipal sewer service using between 15,001 and 100,000 cubic feet of

water, with or without a water meter, the charge shall be an amount equal to the sum of \$126.00 per month plus \$4.91 per 100 cubic feet of water used.

D. For each water meter of every nonresidential property receiving municipal sewer service using more than 100,001 cubic feet of water, with or without a water meter, the charge shall be an amount equal to the sum of \$252.00 per month plus \$4.91 per 100 cubic feet of water used.

2. Residential Customers. For each water meter of every residential property (including multiple-family residential properties) receiving municipal sewer service, with or without a water meter, the charge shall be an amount equal to the sum of \$31.50 per month per dwelling unit plus \$4.91 per 100 cubic feet of water used.”

**SECTION 3. REPEALER.** All ordinances or parts of ordinances in conflict with the provisions of this ordinance are hereby repealed.

**SECTION 4. SEVERABILITY CLAUSE.** If any section, provision or part of this ordinance shall be adjudged invalid or unconstitutional such adjudication shall not affect the validity of the ordinance as a whole or any section, provision or part thereof not adjudged invalid or unconstitutional.

**SECTION 5. WHEN EFFECTIVE.** This ordinance shall be in effect from and after its final passage, approval and publication as provided by law.

PASSED AND APPROVED by the City Council on the \_\_\_\_ day of \_\_\_\_\_, 2023.

\_\_\_\_\_  
Millie Youngquist, Mayor Pro Tem

ATTEST:

\_\_\_\_\_  
Sally Y. Hart, City Clerk

Approved on First Reading: \_\_\_\_\_

Approved on Second Reading: \_\_\_\_\_

Approved on Third & Final Reading: \_\_\_\_\_

I certify that the foregoing was published as Ordinance No. \_\_\_\_\_ on the \_\_\_\_\_ day of \_\_\_\_\_, 2023.

\_\_\_\_\_  
City Clerk



**City of Washington, Iowa**  
**Water Enterprise Fund**

**EXHIBIT 1**

Growth Assumptions	
Water Usage	0.00%
Operating Expenses	4.00%
Interest Rate	0.00%
Group Insurance & Utilities	8.00%

Water Revenue Adjustment	
12/1/2020	7.54%
6/15/2021	7.47%
6/15/2022	5.00%
6/15/2023	9.50%
6/15/2024	9.00%
6/15/2025	7.50%
6/15/2026	6.50%
6/15/2027	6.50%

	Audited Financial Statements						Unaudited			Budget	Projected	Projected	Projected	Projected	Projected
	FY 2018-19	FY 2019-20	FY 2020-21	FY 2021-22	FY 2022-23	FY 2023-24	FY 2024-25	FY 2025-26	FY 2026-27	FY 2027-28					
Per 100 Cu. Ft.	6/19/2018	6/18/2019	12/1/2020	6/15/2021	6/15/2022	6/15/2023	6/15/2024	6/15/2025	6/15/2026	6/15/2027	6/15/2028				
Base Rate per Month	\$3.97	\$4.11	\$4.42	\$4.75	\$4.99	\$5.46	\$5.96	\$6.40	\$6.82	\$7.26					
Avg. Number of Customers	\$17.85	\$17.85	\$17.85	\$17.85	\$17.85	\$19.55	\$21.30	\$22.90	\$24.39	\$25.98					
Avg \$/100 CF (without Base)	3,005	3,019	3,047	3,061	3,061	3,061	3,061	3,061	3,061	3,061					
Consumption (100 cubic ft)	\$4.14	\$3.94	\$4.26	\$4.32	\$4.54	\$4.97	\$5.42	\$5.82	\$6.20	\$6.60					
Total Water Usage	226,281	-4.39%	216,351	219,335	219,335	219,335	219,335	219,335	219,335	219,335					
<b>Operating Revenues</b>															
Usage Fees	\$936,278	\$852,914	\$947,339	\$947,919	\$995,315	\$1,089,870	\$1,187,958	\$1,277,055	\$1,360,064	\$1,448,468					
Base Rate Fees	643,600	646,706	652,614	655,720	655,720	718,013	782,634	841,332	896,018	954,260					
Penalties	76,741	61,602	67,570	66,939	67,000	67,000	67,000	67,000	67,000	67,000					
Sales Tax/WET	103,566	83,243	90,930	93,958	106,316	126,552	137,941	148,287	157,926	168,191					
Water Deposits	21,825	21,300	20,400	17,100	25,000	25,000	25,000	25,000	25,000	25,000					
Misc Charges	8,725	11,262	5,044	23,023	6,400	6,400	6,400	6,400	6,400	6,400					
Total Operating Revenues	\$1,790,735	\$1,677,026	\$1,783,897	\$1,804,659	\$1,855,751	\$2,032,835	\$2,206,934	\$2,365,074	\$2,512,408	\$2,669,319					
<b>Operating Expenditures</b>															
Personnel	\$441,677	\$421,792	\$443,619	\$427,704	\$470,350	\$489,164	\$508,731	\$529,080	\$550,243	\$572,253					
Group Insurance	143,940	160,619	168,985	162,273	170,831	184,498	199,257	215,198	232,414	251,007					
Repairs & Maintenance	159,392	160,200	92,071	101,772	111,200	115,648	120,274	125,085	130,088	135,292					
Utilities	219,390	209,803	217,334	226,781	225,000	243,000	262,440	283,435	306,110	330,599					
Contractual	37,998	32,940	92,197	56,123	71,700	74,568	77,551	80,653	83,879	87,234					
Commodities / Other Supplies	75,761	200,402	106,401	140,248	110,500	114,920	119,517	124,297	129,269	134,440					
Taxes	93,162	86,621	89,909	93,804	106,316	126,552	137,941	148,287	157,926	168,191					
Chemicals	91,244	98,726	84,068	81,324	95,000	98,800	102,752	106,862	111,137	115,582					
Water Deposit Refunds	18,865	18,075	21,645	15,075	23,400	25,000	25,000	25,000	25,000	25,000					
Miscellaneous	3,142	1,873	2,087	9,694	6,975	7,254	7,544	7,846	8,160	8,486					
Total Operating Expense	\$1,284,571	\$1,391,051	\$1,318,316	\$1,314,798	\$1,391,272	\$1,479,403	\$1,561,007	\$1,645,743	\$1,734,225	\$1,828,084					
Net Operating Income	\$506,164	\$285,975	\$465,581	\$489,861	\$464,479	\$553,432	\$645,927	\$719,331	\$778,183	\$841,235					
Interest Income	1,363	277	251	723	500	0	0	0	0	0					
Net Revenue for Debt Service	\$507,527	\$286,252	\$465,832	\$490,584	\$464,979	\$553,432	\$645,927	\$719,331	\$778,183	\$841,235					

**RESOLUTION NO. 2023-\_\_\_**

**A RESOLUTION AUTHORIZING TAX ABATEMENT  
UNDER THE WASHINGTON URBAN REVITALIZATION PLAN  
FOR WASHINGTON, IOWA**

WHEREAS, the City of Washington, Iowa, has a property tax exemption for improvements under the provisions of the Washington Urban Revitalization Plan adopted by the City Council of the City of Washington, Iowa; and

WHEREAS, all qualified real estate assessed as residential property is eligible to receive a one hundred percent exemption from taxation on the first seventy-five thousand dollars of actual value added by the improvements with the exemption for a period of three years; and

WHEREAS, improvements must increase the assessed value by a minimum of ten percent; and

WHEREAS, the attached application for 6 Circle Drive Washington, a residence owned by Kurt M. & Christa D. Venenga, Parcel ID 1120257002, has been completed and reviewed by staff and is recommended for approval.

NOW, THEREFORE, BE IT RESOLVED BY THE COUNCIL OF THE CITY OF WASHINGTON, IOWA that the City Clerk be instructed to certify the attached application and submit it to the Washington County Assessor.

Passed and Approved this 2nd day of May, 2023.

\_\_\_\_\_  
Millie Youngquist, Mayor Pro Tem

Attest:

\_\_\_\_\_  
Sally Y. Hart, City Clerk

APPLICATION FOR TAX ABATEMENT UNDER THE  
WASHINGTON URBAN REVITALIZATION PLAN FOR  
WASHINGTON, IOWA

\_\_\_\_\_ Prior Approval for Intended Improvements

\_\_\_\_\_ Approval of Improvements Completed

FOR PROPERTY TAX EXEMPTION FOR IMPROVEMENTS UNDER THE PROVISIONS OF THE WASHINGTON  
URBAN REVITALIZATION PLAN ADOPTED BY THE CITY COUNCIL OF THE CITY OF WASHINGTON, IOWA

The Washington Urban Revitalization Plan allows property tax exemptions as follows:

Residential

All qualified real estate assessed as residential property is eligible to receive a one hundred percent (100%) exemption from taxation on the first seventy-five thousand dollars (\$75,000) of actual value added by the improvements. The exemption is for a period of three (3) years. Improvements must increase the assessed value by a minimum of 10%.

Commercial/Industrial

All qualified real estate assessed as commercial and/or industrial property is eligible to receive a partial exemption from taxation on the actual value added by the improvements. The exemption is for a period of five (5) years. Improvements must increase the assessed value by a minimum of 10%. The amount of the partial exemption is equal to a percent of the actual value added by the improvements, determined as follows:

- 1) First Year - 75% Exemption
- 2) Second year - 60% Exemption
- 3) Third Year - 45% Exemption
- 4) Fourth Year - 30% Exemption
- 5) Fifth Year - 15% Exemption

Commercial includes property that consists of 3 or more separate living quarters with at least 75% of the space used for residential purposes.

In order to be eligible, the property must be located in the Washington Revitalization Area. A map is available for inspection at City Hall.

This application must be filed with the City by February 1 of the assessment year for which the exemption is first claimed, but not later than 2 years after the February 1<sup>st</sup> following the year that the improvements are first assessed for taxation.

Address of Property: 6 Circle Dr Washington, Iowa 52353

Legal Description: 02 Circle Dr SD City of Washington in Washington County Iowa

Title Holder or Contract Buyer: Kurt M & Christa D Venenga

Address of Owner (if different than above): \_\_\_\_\_

Phone Number (to be reached during the day): 319-591-1115

Is there a Tenant on the Property that will be displaced by the Improvements who has occupied the same dwelling unit continuously for 1 year prior to \_\_\_\_\_ [insert date of adoption of the Plan]? Yes \_\_\_ No

Existing Property Use:  Residential \_\_\_ Commercial \_\_\_ Industrial \_\_\_ Vacant

Proposed Property Use: residential

Nature of Improvements:  New Construction \_\_\_ Addition \_\_\_ General Improvements

Specify: \_\_\_\_\_

Permit Number(s) from the City of 220113 \_\_\_ Building Department

Date Permit(s) Issued: \_\_\_\_\_

Permit(s) Valuation: \_\_\_\_\_ [Attach approved Building Permit to this application]

Estimated or Actual Date of Completion: 12-3-2022

Estimated or Actual Cost of Improvements: \$ 295,000

Signature: *Christa Venenga*

Name (Printed) Christa Venenga

Title: owner

Company: \_\_\_\_\_

Date: 2-1-2013

**FOR CITY USE**

<b>CITY COUNCIL</b>	Application Approved/Disapproved _____
	Reason (If disapproved) _____
	Date _____ Resolution No. _____
	Attested by the City Clerk _____
<b>ASSESSOR</b>	Present Assessed Value of Structure _____
	Assessed Value with Improvements _____
	Eligible or Noneligible for Tax Abatement _____
	Assessor _____ Date _____

\* Example: To receive a full 5 year exemption on Improvements that were first fully assessed on 1-1-2012, the property owner must file the application with the City no later than 2-1-2014.

This Application is a summary of some of the Plan terms; for complete information, read a copy of the WASHINGTON URBAN REVITALIZATION PLAN, available at City Hall.

**ATTACHMENTS: ATTACH YOUR APPROVED BUILDING PERMIT TO THIS APPLICATION**

**This Application is to be forwarded by the City to the County Assessor by March 1.**

# Certificate of Occupancy

Department of Building Inspection  
Washington Iowa  
215 E Washington St  
Washington, IA 52353  
Zoning Permit Number: 220113



This certificate is issued pursuant to the requirements of §165.24.B. of the City of Washington Code. This document certifies that at the time of issuance this structure was in compliance with the various ordinances of the city regulating building construction or use for the following:

Date: 12/02/2022

Occupancy Number: 220367

Building Address: 6 CIRCLE DR.

Stipulations or conditions: None.

Owner: A.C.E. SIGNATURE HOMES, LLC

Owner Address: 305 N. Main St.

Code Year: 2018 IRC

A handwritten signature in black ink, appearing to read "Jeff Duwa".

Jeff Duwa  
Building & Zoning Administrator

Jaron P. Rosien, Mayor  
Sally Hart, City Clerk  
Kevin Olson, City Attorney  
Deanna McCusker, City  
Administrator



City of Washington  
215 East Washington Street  
Washington, Iowa 52353  
(319) 653-6584 Phone  
(319) 653-5273 Fax

## Residential Building Permit

Permit Number: 220113  
Property Address: 6 CIRCLE DR.

Project Cost: 250000  
Issue Date: 04/26/2022  
Expiration Date: 10/17/2022

Job Description: NEW CONSTRUCTION SINGLE FAMILY HOUSE

Owner:  
A.C.E. SIGNATURE HOMES, LLC  
305 N. Main St.  
North Liberty, IA 52317

Contractor:  
CML CONSTRUCTION LLC  
SAME  
SAME

Fees	Amount	Payments	Account Paid
Building Zoning Permit Fee	\$1,191.94	CML Construction	\$1,191.94
<b>Total Fee: \$1,191.94</b>		<b>Total Paid: \$1,191.94</b>	

Notes:

A handwritten signature in black ink, appearing to read "Jeff Duwa".

Issued By Jeff Duwa

04/20/2022

Date