



AGENDA OF THE REGULAR SESSION OF THE
COUNCIL OF THE CITY OF WASHINGTON, IA
TO BE HELD AT THE
COUNCIL CHAMBERS
215 E. WASHINGTON STREET
AT 6:00 P.M., TUESDAY, SEPTEMBER 17, 2024

Call to Order

Pledge of Allegiance

Roll Call

Approval of the Agenda

Consent:

1. Council Minutes for September 17, 2024 Regular Session
2. DCJ Concrete and General Construction, Sidewalk Replacement Program, \$6,497.20
3. DCJ Concrete and General Construction, Sidewalk Replacement Program, \$4,241.00
4. Iowa Municipalities Workers' Compensation Association, Work Comp Premium 24-25 Installment 3, \$5,826.00
5. Paws and More, FY25 Payment for 2023 Animal Services, \$22,436.20
6. Washington Spirits & Tobacco, 1061 W. Madison Street, Class E Retail Alcohol License (**renewal**)
7. Lebowski's of Washington, 1601 E. Washington Street, Class C Retail Alcohol License (**renewal**)
8. Urban Chicken Permit, Jacob Sanow, 825 S. 4th Avenue (**new**)
9. Department Reports

SPECIAL PRESENTATION

- Mayoral Proclamation – Domestic Violence Awareness Month

SPECIAL EVENT REQUEST

PUBLIC COMMENT – Please limit comments to 3 Minutes

CLAIMS & FINANCIALS

- Claims Report for September 17, 2024
- July 2024 Financial Report

PUBLIC HEARING

- Intent to Vacate and Dispose of a Portion of North Third Avenue and a Portion of the Alley Behind 302 and 315 East Third Street

NEW BUSINESS

1. Discussion and Consideration of a First Reading of an Ordinance Vacating a Portion of North Third Avenue and Alley ROW (302 and 315 East Third Street)
2. Discussion and Consideration of Approving the Purchase of Replacement Auger Parts from Vulcan Industries in the amount of \$10,543.00
3. Discussion and Consideration of a Resolution Releasing Funds as per a Downtown Investment Grant Agreement with Lux Suites for the Renovation of 110 West Main Street
4. Discussion and Consideration for a Resolution to Provide for a Notice of Hearing and Letting on Proposed Plans, Specifications, Form of Contract and Estimate of Cost for the Central Park Restroom Project and Taking of Bids Therefore.
5. Discussion and Consideration of the Second Reading of an Ordinance Amending the Municipal Code of the City of Washington, Iowa, by Amending Chapter 69 (Additions)
6. Discussion and Consideration of a Resolution Authorizing Levy, Assessment, and Collection of Costs to the Washington County Treasurer

UNFINISHED BUSINESS

1. Discussion and Consideration of the First Reading of an Ordinance Amending the Municipal Code of the City of Washington, Iowa, by Amending Chapter 50 and 51 (Tabled 09/03/2024)

CLOSED SESSION

- Closed Session per Iowa Code 21.5(1)(i) – *to evaluate the professional competency of an individual whose appointment, hiring, performance, or discharge is being considered when necessary to prevent needless and irreparable injury to that individual's reputation and that individual requests a closed session.*

1. Formal action for any items discussed in Closed Session

DEPARTMENTAL REPORTS

Police Department
City Attorney
City Administrator

MAYOR & COUNCILPERSONS

Millie Youngquist, Mayor
Illa Earnest
Patrick Morgan
Elaine Moore
Ivan Rangel
Kenneth Schroeder
Fran Stigers

ADJOURNMENT

CITY OF WASHINGTON
Council Minutes 9-3-2024

At 6:00 p.m. the Council of the City of Washington, Iowa, met in Regular Session in the Council Chambers, 215 East Washington Street with Mayor Youngquist in the chair.

On roll call present: Morgan, Moore, Rangel, Earnest, Schroeder, Stigers. Absent: none.

Mayor Youngquist asked for a Motion for approval of the Agenda. Motion by Stigers, second by Moore to approve the Agenda. Motion carried.

Consent:

1. Council Minutes for August 20, 2024 Regular Session
2. Ahlers and Cooney, Amendment 2 – Unified South Central Residential URP, \$97.00
3. Bolton and Menk, Hangar Rehab, \$4,945.00
4. Keokuk County Sheriff, Officer Butler Contract Payout, \$13,784.96
5. Kevin Olson, July Legal Services, \$951.42
6. Reed Construction, Pay Application 8 MakeIt Place, \$13,861.43
7. Stivers, 2024 Ford Police Interceptor, \$37,035.00
8. Stivers, 2024 Ford Police Interceptor-Investigator, \$45,535.00
9. Veenstra and Kimm, Central Park Restrooms, \$402.50
10. Veenstra and Kimm, Wellness Park Concession Stand, \$111.50
11. Department Reports

Motion by Morgan, second by Stigers to approve consent items 1-11. Motion Carried.

Motion by Stigers, seconded by Rangel to approve a Special Event Request for Marion Avenue Baptist Church, Fund Day in the Park, September 21, 2024, 10 A.M. – 1:30 P.M. in Central Park Motion carried.

Motion by Moore, seconded by Stigers to approve a Special Event Request for Emporium-Melanie James, Holistic Wellness Fair, October 18-19, 2024, 10 A.M. – 3:00 P.M. in Blair House/City Hall parking lot. Park Motion carried.

Motion by Earnest, seconded by Morgan to approve an additional closure for the Special Event Request for Washington Chamber of Commerce, Fall Craft Fair, September 7, 2024, 7 A.M. – 5:00 P.M. in Central Park. Park Motion carried.

Public Comment: none.

The claims were presented by Finance Director, Kelsey Brown.

**CITY OF WASHINGTON, IOWA
CLAIMS BY FUND
SEPTEMBER 3, 2024**

GENERAL

ACCESS SYSTEMS	COPIER MAINTENANCE	3.36
ACCESS SYSTEMS LEASING	COPIER LEASE	433.61
	DUTY	
ACE-N-MORE	WEAPON/PADLOCK/AMMO/SUPP	1099.97
ALLIANT ENERGY	ALLIANT ENERGY	5422.42
AMAZON CAPITAL SERVICES	OFFICE/ILEA/SAFETY SUPPLIES	1602.22
ARMSTRONG HEATING & AC INC	REPAIR/MAINTENANCE/AIR FILTERS	488.50
ARNOLD MOTOR SUPPLY	SUPPLIES	34.20
ATCO INTERNATIONAL	SUPPLIES	161.55
BAKER & TAYLOR	LIBRARY MATERIALS	343.24
BDH TECHNOLOGY LLC	LAPTOP FOR ILEA/HARD DRIVE	1503.67
BLUE MOON SATELLITES, LLC	PORTABLE TOILETS	547.50
BOUND TREE MEDICAL, LLC	AED PAD	18.99
CALIBRE PRESS INC.	TRAINING-B ALTENHOFEN	359.00
CAPITAL ONE	TRAINING MATERIALS/SUPPLIES	342.09
CENGAGE LEARNING INC/GALE	LIBRARY MATERIALS	49.48
CENTRAL IOWA DISTRIBUTING	JANITORIAL SUPPLIES	119.00
CINTAS CORP LOC. 342	TOWEL/MAT/RUG SERVICE	286.53
CJ COOPER & ASSOC.	APPLICANT TESTING	50.00
COBB OIL CO., INC-BP ONE TRIP	FUEL	20.32
DE LAGE LANDEN PUBLIC FINANCE LLC	MDT LEASE	577.88
DUO-SAFETY LADDER CORP	SUPPLIES	96.06
GALLS LLC	SUPPLIES	1153.90
GFC LEASING - WI	PRINTER LEASE	244.19
GLANDON'S WESTSIDE SERVICE	TRAILER/MINI TRUCK TIRES	514.00
IGRAPHIX, INC	TIMESHEETS	54.00
IMPRESSIONS COMPUTERS, INC	COMPUTER MAINTENANCE	318.75
KCII	PROGRAM PROMO/ADVERTISING	212.16
KCTC	COMPUTER SRV & PARTS & EQUIP	2334.96
LOWRY EQUIPMENT	KABOTA BLADES	169.52
MARCO, INC.	COPIER PRINTER LEASE	449.99
PITNEY BOWES GLOBAL FIN SERVICES LLC	PITNEY BOWES GLOBAL FIN SE	259.44
POPEJOY, ELIANA	24 MUNICIPAL BAND PAY	87.00
PRO-LOK	VEHICLE LOCK SUPPLIES	102.35
RANGEMASTERS TRAINING CENTER	UNIFORM AND EQUIPMENT	637.21
REEVES COMPANY, INC.	NAME PIN FOR NEW HIRE	34.68
RIGHTER, ISABELLE	24 MUNICIPAL BAND PAY	43.50
SIMMERING-CORY, INC.	JULY 24TH SUPPLEMENT	849.00
SIRCHIE	EVIDENCE SUPPLIES	122.93

STANARD & ASSOCIATES INC	APPLICANT TESTING	66.50
TOP SAW TREE SERVICE LLC	TREE REM 628 W MAIN/1104 E 2ND	1975.00
VISA-TCM BANK, N.A.	ILEA, TEST-MEAL, DUES,CONF,SUPP	1289.40
WASH CHAMBER OF COMMERCE	LEADERSHIP WASH CLASS	350.00
WASH CO RECORDER	RECORDING	187.00
WASHINGTON LUMBER	GARBAGE CANS	30.56
WASHINGTON RENTAL	16 " BAR & CHISELS/FILTER/PARTS	345.83
WIBSTAD, ZACH	MEAL REIMBURSEMENT	21.54
WITMER PUBLIC SAFETY GROUP	BOOTS & LIGHT	955.88
WMPF GROUP LLC	LEGAL ADVERTISING	359.13
	TOTAL	26728.01

AIRPORT

CLOUDBURST 9	INTERNET	84.95
TITAN AVIATION FUELS	JET FUEL	20813.69
VISA-TCM BANK, N.A.	ZOOM	17.11
	TOTAL	20915.75

ROAD USE

ALTORFER INC	SAW RENTAL	290.00
ACE-N-MORE	TOOLS & GLOVES	680.42
BARCO MUNICIPAL PRODUCTS INC	SAFETY FENCE	1018.32
CHEMSEARCH FE	SUPPLIES	185.10
COBB OIL CO., INC-BP ONE TRIP	FUEL	106.09
DETROIT INDUSTRIAL TOOL	SAW-BLADES	313.58
DOUDS STONE LLC	ROADSTONE	1446.71
HIWAY SERVICE CENTER	SHOP SUPPLIES	319.03
IOWA PRISON INDUSTRIES	SIGNS	142.10
JOHN DEERE FINANCIAL	LOADER PARTS	83.24
POLLARDWATER	ORANGE CONES	375.00
ROSE EQUIPMENT LLC	PARTS FOR STREET SWEEPER	887.08
TERMINAL SUPPLY CO.	DRILL BITS, CABLE & PARTS	127.53
WASHINGTON LUMBER	GLUE/LUMBER	162.59
WMPF GROUP LLC	EMPLOYMENT	243.10
	TOTAL	6379.89

STREET LIGHTING

ALLIANT ENERGY	ALLIANT ENERGY	320.65
TRAFFIC & TRANSPORTATION	VIDEO TRAFFIC DETECTION	22956.00
	TOTAL	23276.65

HOTEL/MOTEL TAX

VISA-TCM BANK, N.A.	WEB SERV, ADOBE, SUPPLIES	134.41
---------------------	---------------------------	--------

VORTEX DIGITAL BUSINESS SOLUTIONS, INC	WEBSITE UPDATES	145.95
	TOTAL	280.36

CAPITAL PROJECTS

IOWA CITY LANDSCAPING	TREES	326.00
	TOTAL	326.00

WELLNESS PARK

CARSON PLUMBING & HEATING SRVS INC	WELLNESS PARK- UNDER FLOOR	1902.63
CORE & MAIN LP	SOCCER CONCESSION SUPPLIES	1393.28
DOUDS STONE LLC	CONCESSION STAND-ROADSTONE	927.03
RIVER PRODUCTS	PARK CONCESSION STAND	354.34
	TOTAL	4577.28

SIDEWALK REPAIR/REPLACE

CHALUPA, CHERYL L.	SIDEWALK REPLACEMENT PROGR	192.00
DAVIS, KENT	SIDEWALK REPLACEMENT PROGR	192.00
SCHLUTTENHOFER, SHARON	SIDEWALK REPLACEMENT PROGR	576.00
VETTER, STEPHEN & KATHY	SIDEWALK REPLACEMENT PROGR	348.00
	TOTAL	1308.00

RESIDENTIAL DEVELOP

WASH CO RECORDER	RECORDING	64.00
	TOTAL	64.00

TREE COMMITTEE

IOWA CITY LANDSCAPING	TREES	248.00
FLEMING NURSERY	TREES	285.00
KELLY TREE FARM LLC	TREES	1374.82
	TOTAL	1907.82

K-9 PROGRAM

ACE-N-MORE	K9 FOOD	89.98
	TOTAL	89.98

LIBRARY GIFT

VISA-TCM BANK, N.A.	SUPPLIES, ZOOM, SOFTWARE	418.01
AMAZON CAPITAL SERVICES	MIP SUPPLIES	32.97
CAPITAL ONE	SUPPLIES, PROGRAM SUPPLIES	330.23
OVERDRIVE, INC.	DIGITAL SERVICES	487.80
TUCCI, JESSICA H.	8/17 & 8/31 POTTERY CLASS	883.48
	TOTAL	2152.49

WATER UTILITY

ALLIANT ENERGY	ALLIANT ENERGY	5636.36
CHEMSEARCH FE	SUPPLIES	1474.20
CORE & MAIN LP	PIPE-SUPPLIES	2716.80
DOUDS STONE LLC	ROADSTONE	722.23
GIERKE ROBINSON CO., INC	PAINT FOR LOCATES	215.52
GLASPIE, DEREK	WATER DEPOSIT REFUND	110.61
HELLERICH, ELAINE	WATER DEPOSIT REFUND	493.53
IDEAL READY MIX	WATER MAIN LEAK REPAIR	4138.75
KRONAIZL, KIRK	WATER DEPOSIT REFUND	104.32
KUJACZYNSKI, JAMIE	WATER DEPOSIT REFUND	91.06
NEXT LEVEL REAL ESTA	WATER DEPOSIT REFUND	35.59
NUTSHELL INDUSTRIES	WATER DEPOSIT REFUND	119.98
PACHA, ADRIANNA	WATER DEPOSIT REFUND	66.06
PARKER, HEIDI	WATER DEPOSIT REFUND	98.26
POSTMASTER	BULK MAILING WATER BILLS 8	1268.46
RUIZ, DOROTHY	WATER DEPOSIT REFUND	25.27
SEITZ, TRAVIS	WATER DEPOSIT REFUND	22.54
TYLER TECHNOLOGIES	COMPUTER SOFTWARE	10648.51
	TOTAL	27988.05

SEWER UTILITY

AGRILAND FS, INC	GRASS SEED	596.76
ALLIANT ENERGY	ALLIANT ENERGY	406.74
ARNOLD MOTOR SUPPLY	SUPPLIES	1.60
ATCO INTERNATIONAL	SAFETY GLOVES	302.55
GIERKE ROBINSON CO., INC	PAINT FOR LOCATES	215.40
HARRIS BOYZ HEATING & AIR LLC	A/C REPAIR	395.00
IA DEPT OF NATURAL RESOURCES	WWTP ANNUAL PERMIT	1275.00
IOWA PUMP WORKS INC	ANNUAL SERVICE/PUMP REPAIR	8134.10
KCTC	POWER BACKUP	285.99
TYLER TECHNOLOGIES	COMPUTER SOFTWARE	10648.50
USA BLUEBOOK	FLAGS FOR LOCATES	241.89
VISA-TCM BANK, N.A.	MOWER WHEEL GUIDE	37.53
	TOTAL	22541.06

SANITATION

WASH CO HUMANE SOCIETY	AUGUST 2024 COLLECTIONS	339.96
	TOTAL	339.96

TOTAL **138875.30**

Motion by Morgan, second by Earnest to approve claims report. Motion carried.

The June 2024 Financial Report were presented by Finance Director, Kelsey Brown.

Motion by Moore, second by Morgan to approve the June 2024 Financial Report. Motion carried.

Discussion and Consideration of a Resolution Approving the Third Amendment to the Agreement for Private Development By and Between the City of Washington, Iowa and Washington Hotel Group, LLC. Motion by Stigers, second by Rangel. Roll call on motion. Ayes: Earnest, Morgan, Moore, Rangel, Schroeder, Stigers. Nays: none. **(RESOLUTION 2024-059)**

Discussion and Consideration of a Resolution Releasing Funds as per a Downtown Investment Grant Agreement with DW Developments for the Upper Floor Renovation at 111 N Marion Avenue. Motion by Earnest, second by Morgan. Roll call on motion. Ayes: Earnest, Morgan, Moore, Rangel, Schroeder, Stigers. Nays: none. **(RESOLUTION 2024-060)**

Discussion and Consideration of a Resolution Amending the Employee Handbook for the City of Washington, Iowa. Motion by Earnest, second by Schroeder. Roll call on motion. Ayes: Earnest, Morgan, Moore, Rangel, Schroeder, Stigers. Nays: none. **(RESOLUTION 2024-061)**

Discussion and Consideration of a Resolution Authorizing Fiscal Year End 2024 Transfers. Motion by Moore, second by Stigers. Roll call on motion. Ayes: Earnest, Morgan, Moore, Rangel, Schroeder, Stigers. Nays: none. **(RESOLUTION 2024-062)**

Discussion and Consideration of a Resolution Declining to Exercise Extraterritorial Jurisdiction for Parcel 1024100001. Motion by Earnest, second by Schroeder. Roll call on motion. Ayes: Earnest, Morgan, Moore, Rangel, Schroeder, Stigers. Nays: none. **(RESOLUTION 2024-063)**

Discussion and Consideration of the Third Reading of an Ordinance Amending the Municipal Code of the City of Washington, Iowa, by Amending Chapter 69. Motion by Moore, second by Morgan. Roll call on motion. Ayes: Earnest, Morgan, Moore, Rangel, Schroeder, Stigers. Nays: none.

Discussion and Consideration of the First Reading of an Ordinance Amending the Municipal Code of the City of Washington, Iowa, by Amending Chapter 50 and 51. Motion by Stigers, second by Morgan to table the item for further discussion. Roll call on motion. Ayes: Earnest, Morgan, Moore, Rangel, Schroeder, Stigers. Nays: none.

Discussion and Consideration of the First Reading of an Ordinance Amending the Municipal Code of the City of Washington, Iowa, by Amending Chapter 69. Motion by Moore, second by

Stigers. Roll call on motion. Ayes: Earnest, Morgan, Moore, Rangel, Schroeder, Stigers. Nays: none.

Discussion and Consideration of a Resolution Approving an Authorizing Levy, Assessment, and Collection Costs to the Washington County Treasurer. Motion by Moore, second by Earnest. Roll call on motion. Ayes: Earnest, Morgan, Moore, Rangel, Schroeder, Stigers. Nays: none. **(RESOLUTION 2024-064)**

Department reports were presented.

Motion by Stigers, second by Morgan that the Regular Session held at 6:00 p.m., Tuesday, September 3, 2024, is adjourned at 6:47 p.m. Motion passed unanimously.

Millie Youngquist, Mayor

Kelsey Brown, Deputy City Clerk

DCJ Concrete & General Construction



320 West Van Buren
 Washington, IA 52523
 319-460-0408

PREPARED FOR:
 City of Washington

Sidewalk Project
 North 7th ave
 East Main st
 East 2nd st

Prepared date: September 2nd, 2024

Address	SqFt Concrete 4"	SqFt Concrete 6"
110 N 7th ave	48	
116 N 7th ave	16	
601 N 7th ave	192	64
609 N 7th ave	16	80
621 N 7th ave	115.8	
808 N 7th ave	48	64
815 N 7th ave	48	
904 N 7th ave	110	32
912 N 7th ave	56	
1020 N 7th ave	64	
818 N 7th ave	38	
1002 N 7th ave	63	
910 N 7th ave	32	
326 East 2nd st	150.8	64
316 E Main st	88	18.4
Stump grinding pending \$400.00	<u>1085.6</u>	<u>322.4</u>

$1085.6 \times 4.50 = 4885.20$

$322.4 \times 5.00 = 1612.00$

Total = 6497.20

Total due: 9/11/24
~~\$7023.00~~
 \$6497.20

**DCJ Concrete & General
Construction**

320 West Van Buren
Washington, IA 52523
319-460-0408



PREPARED FOR:

City of Washington

Sidewalk Project

North 8th ave

Prepared date: September 11th, 2024

Address	SqFt Concrete 4"	SqFt Concrete 6"	
715 N 8th ave	32		
809 N 8th ave	176.8	56	
815 N 8th ave	87.2	75	
821 N 8th ave	416	76.4	

Total due: \$4,241.00

Iowa Municipalities Workers' Compensation Assoc
 500 SW 7th Street
 Suite 101
 Des Moines IA 50309

Invoice	INV91527
Date	9/1/2024
Page	1

Bill To:

Washington, City of
 215 E Washington
 Washington IA 52353

Ship To:

Washington, City of
 215 E Washington
 Washington IA 52353

Please remit payment to: IMWCA, PO Box 8186, Des Moines, IA 50301

Purchase Order No.		Customer ID	Salesperson ID	Shipping Method	Payment Terms	Req Ship Date	Master No.
		WASHI001	AG0075		NET 30	9/1/2024	98,527
Ordered	Shipped	B/O	Item Number	Description	Discount	Unit Price	Ext. Price
1	1	0	INSTALL3	Installment 3 - Work Comp Prem 24-25	\$0.00	\$5,826.00	\$5,826.00

This invoice is due by October 1, 2024.

Subtotal	\$5,826.00
Misc	\$0.00
Tax	\$0.00
Freight	\$0.00
Trade Discount	\$0.00
Total	\$5,826.00

A FINANCE CHARGE of 1.5% (APR 18%) will be added to balances over 30 days past due.
 When you provide a check as payment, you authorize IMWCA either to use the information from your check to make a one-time electronic fund transfer from your account or to process the payment as a check transaction. For inquiries please call 515-244-7282.

Statement for:

9/11/2024

City of Washington
215 E Washington Street
Washington, IA 52353

Animal Care Services Provided

FY2025	2023 full year	\$ 22,436.20
--------	----------------	--------------

TOTAL DUE \$ 22,436.20

Please make checks payable to:
Washington County Humane Society
1004 1/2 W Madison Street
Washington, IA 52353

THE CITY OF WASHINGTON

"Cleanest City in Iowa"



Millie Youngquist, Mayor
Joe Gaa, City Administrator
Kelsey Brown, Finance Director
Kevin Olson, City Attorney

P.O. Box 516
215 E. Washington St.
Washington, IA 52353
319-653-6584
Fax Only 319-653-5273

NOTIFICATION FORM -
LIQUOR/BEER/CIGARETTE/DANCE
LICENSE RENEWALS

Business Name: **Washington Spirits & Tobacco**

Business Address: **1061 W. Madison, Washington, Iowa**

App # : **App-208138**

Type of License: New: _____ Renewal: X Special Five-Day: _____
Amendment: _____

Permanent Premise Transfer:

Beer/Wine Permit:

Liquor License: **Class E Retail Alcohol License**

Automatic Renewal:

Cigarette License:

Dance Permit:

Sunday Sales: **Sunday sales are now an inherent privilege included in your license type with no additional fee. You are no longer required to choose Sunday Sales as a separate privilege.*

Living Quarters:

Outdoor Service Area:

Catering Privilege:

Date of Council Meeting: **September 17, 2024**

Police: DCI background check and/or local background check: Yes: _____ No: _____
Police Chief sign off [Signature] . Date 9-9-2024 .

Fire: fire inspection done: Yes: _____ No: _____
Fire Chief sign off _____ . Date _____ .

License Application (LE0004134)

▪ Applicant

Name of Legal Entity : MSU 2020 LLC

Name of Business(DBA) : WASHINGTON SPIRITS & TOBACCO

Address of Premises : 1061 West Madison Street

Premises Suite/Apt Number :

City : Washington

County : Washington

Zip : 52353

Business : (262) 321-8911

Mailing Address: 901 S MAIN ST

City : FAIRFIELD

State : Iowa

Zip : 52556

▪ Contact Person

Name : DANNY UMAR

Phone : (262) 321-8911

Email : dumar58@gmail.com

Zip : 52556

Position : OWNER

% of ownership : 100%

U.S. Citizen : Yes

- **Insurance Company Information**

-

-

THE CITY OF WASHINGTON
"Cleanest City in Iowa"



Millie Youngquist, Mayor
Joe Gaa, City Administrator
Kelsey Brown, Finance Director
Kevin Olson, City Attorney

P.O. Box 516
215 E. Washington St.
Washington, IA 52353
319-653-6584
Fax Only 319-653-5273

NOTIFICATION FORM -
LIQUOR/BEER/CIGARETTE/DANCE
LICENSE RENEWALS

Business Name: **Lebowski's of Washington**

Business Address: **1601 E. Washington Street, Washington, Iowa**

App # : **App-204437**

Type of License: New: _____ Renewal: X Special _____ Five-Day: _____
Amendment: _____

Permanent Premise Transfer:

Beer/Wine Permit:

Liquor License: **Class C Retail Alcohol License**

Automatic Renewal:

Cigarette License:

Dance Permit:

Sunday Sales: **Sunday sales are now an inherent privilege included in your license type with no additional fee. You are no longer required to choose Sunday Sales as a separate privilege.*

Living Quarters:

Outdoor Service Area: X

Catering Privilege: X

Date of Council Meeting: **September 17, 2024**

Police: DCI background check and/or local background check: Yes: _____ No: _____
Police Chief sign off [Signature] . Date 9.9.2024 .

Fire: fire inspection done: Yes: _____ No: _____
Fire Chief sign off _____ . Date _____ .

▪ **License Information**

License Number : LC0040294

License/Permit Type : Class C Retail Alcohol License

Term : 12 Month

Status : Submitted to Local Authority

Effective Date : 2024-08-30

Expiration Date : 2025-08-29

Sub-Permits : Class C Retail Alcohol License

Privileges : Outdoor Service, Catering

Last Day of Business :

▪ **Status of Business**

Business Type : Corporation

▪ **Ownership**

robert gaal

City : washington

State : iowa

Zip : 52353

Position : President

% of ownership : 100%

U.S. Citizen : Yes

■ **Insurance Company Information**

Insurance Company : Auto Owners Insurance Company

Policy Effective Date : 2024-08-30

Policy Expiration : 2025-08-30

Bond Effective :

Dram Cancel Date :

Outdoor Service Effective :

Outdoor Service Expiration :

Temp Transfer Effective Date :

Temp Transfer Expiration Date :

Millie Youngquist, Mayor
 Joe Gaa, City Administrator
 Kelsey Brown, Finance Director
 Kevin Olson, City Attorney



City of Washington
 215 East Washington Street
 Washington, Iowa 52353
 (319) 653-6584 Phone
 (319) 653-5273 Fax

Urban Chicken Permit Application

***Failure to complete all sections of the application and provide supporting documentation may result in a return or denial of your application. ***

1. Applicant Information

Name JACOB SAROW
 Property Address 825 S 4th Ave Washington, IA
 Daytime Phone # 319-460-0986 Evening Phone # _____
 Number of chickens &/or poultry to be kept 3
 (No roosters are allowed, Maximum number is 4)

2. Application Checklist

Resident's Submittal

Staff Review

- Landlord sign-off (if applicant is a tenant) _____ N/A
- Description of chicken coop and pen including materials used & cubic feet 71" L x 20" W x 39" H _____ WB
Wood / chicken wire
(Amazon)
- Diagram of the property including dimensions, location of coop and pen, and identification of adjacent properties by street address _____ WB
- Sign-off of all adjacent property owners (please use form attached as Exhibit A) _____ WB

3. Statement of Understanding (Please initial by each item)

Yes 1) I am aware that owners of all adjacent properties (i.e., all properties that contact each other at any point) must give their written consent for any urban chicken permit application to be approved.

Yes 2) I am aware that I must receive approval from the City prior to obtaining chickens.

Yes 3) I will follow all City ordinances and state laws relating to the care and keeping of animals.

Yes 4) I am aware that I am responsible for keeping chickens within the confines of my property at all times.

Yes 5) I am aware that I may not make any dimensional changes to my chicken coop without first obtaining approval from the City of Washington.

Yes 6) I grant the right for City staff to inspect my property at any time to investigate a complaint related to this permit.

Yes 7) I acknowledge that I live in an owner-occupied single-family home, or if renting, have the written permission of my landlord (landlord must provide a signature below).

Yes 8) I affirm that I have never been found guilty of any animal welfare, neglect or cruelty violations.

Yes 9) I understand that the permit is a limited license for the activity, no vested zoning rights arise from this permit and that the permit does not run with the land.

Yes 10) I understand the private restrictions on the use of the property shall remain enforceable and shall supersede the permit. I affirm that there are no private restrictions including, but not limited to, deed restrictions, condominium restrictions, neighborhood association bylaws, covenants, and restrictions and rental agreements. A permit issued to a property subject to private restrictions that prohibit keeping of chickens is void.

Yes 11) I understand that the City Council's approval is good for two years, by which time the City may have developed different guidelines and I must reapply for my continued keeping of chickens.

I affirm that all statements contained in the application and attachments are true and correct and that I the permit holder will keep the chickens in compliance with all related ordinances and as otherwise directed by the City Council. I understand that failure to comply with regulations may result in revocation of the permit and/or issuance of a municipal infraction.

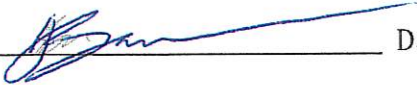
Signature _____  _____ Date 9/09/2024 _____

If applicant is a tenant, the landlord must sign below:

As the owner/authorized manager of the property at _____ (address), I give permission for my tenant _____ (applicant), to install a chicken coop and to keep chickens on the property, as may be approved by the City Council.

CITY OF WASHINGTON, IOWA

NEIGHBOR SIGN-OFF FOR URBAN CHICKEN PERMIT

(EXHIBIT A TO PERMIT APPLICATION)

Any person wanting to keep chickens must first receive written approval from all property owners adjacent to the property for which the permit is requested. Adjacent means all parcels of property which share a property line with the applicant's property, including those that only meet at a single property corner.

Applicant Name: Jacob Sanow

Site Address: 825 S 4th Ave

The above applicant wishes to keep chickens in a coop at the property listed. I/We, being the adjacent property owner(s), have been provided a diagram of the planned coop and pen in relation to the applicant's property lines, and do not object to the above-named person keeping chickens as may be approved by the Washington City Council.

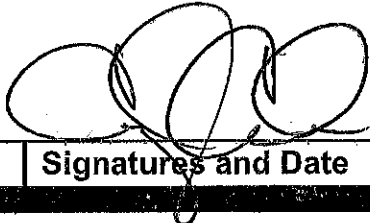
<u>Cheryl Chalupa</u>	<u>819 S. 4th Ave</u>		<u>8/29/24</u>
Names and Address	Phone	Signatures and Date	

(For additional adjacent property owners, please attach additional sheets.)

Alex Clark 319 461 6470 310 E Harrison 9/2/24

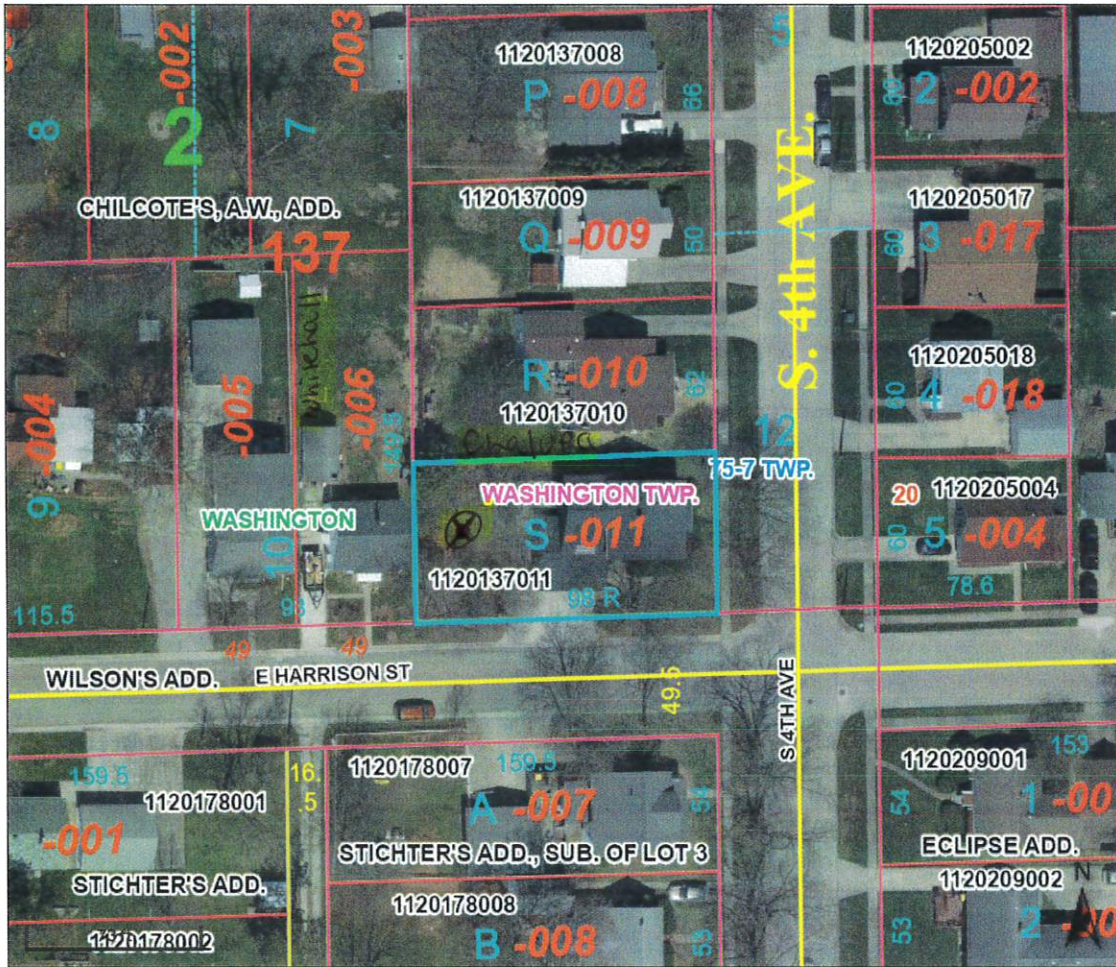

Overview



Legend

- Cadastral Line
- Corp Line
- County Line
- Geo Twp Line
- Lot Line
- Misc Line
- Mon Linear
- Page Match Line
- Parcel Line
- Pol Twp Line
- Railroad Centerline
- Railroad ROW
- Road Centerline
- Road ROW
- Section Line
- Sub Line
- Water Line
- Political Townships
- Geographic Township
- Corporation
- Sections
- Subdivisions
- Parcels
- Road Centerline

North: Chalupa Residence

West: Whitehall Residence

(X): Chicken Coop Location

Parcel ID	1120137011	Class	R	Owner Address	SANOW, DEMITRA & JACOB
Sec/Twp/Rng	n/a	Acreage	n/a		825 S 4TH AVE
Property Address	825 S 4TH AVE WASHINGTON				WASHINGTON, IA 52353
District	WACWS				
Brief Tax Description	5 02 A W CHILCOTES ADD				

(Note: Not to be used on legal documents)

Date created: 8/29/2024
Last Data Uploaded: 8/29/2024 10:26:22 AM



Washington Police Department

James Lester, Chief of Police

215 East Washington Street

Washington, Iowa 52353

Phone: 319-653-2256 Dispatch: 319-653-2107

Rhonda Hill
Administrative Assistant

Shamus Altenhofen
Lieutenant

Jason Chalupa
Sergeant

Benjamin Altenhofen
Sergeant

Brian VanWilligen
Sergeant / Investigator

Eric Kephart
K-9 Handler

Mia Brdecka
Police Officer

Colton Schneider
Police Officer

Devin Fraise
Police Officer

Ryan Burkhardt
Police Officer

Easton Botkins
Police Officer

Noah Kleese
Police Officer

Activity Report August 2024

August was an active month of transition and change for the police department as we saw the retirement of Lt. Lyle Hansen and the resignation of Officer Seth Adam, a total of 53 years-of-service (39 for Hansen and 14 for Adam). We were fortunate to fill those positions in mid-July and Officer Botkins and Officer Kleese both started their 16-week ILEA certification training on August 26th.

Officers handled 605 Calls for Service in August, which included 14 calls to assist with bats, 18 reports of dogs at large, and 22 mental health crisis responses.

The first week of back-to-school was mostly uneventful and officers continue with our practice of targeted patrols around each of the schools during both drop-off and pick-up times.

Respectfully submitted,



Jim Lester
Chief of Police

Washington Police Department

215 East Washington Street

Washington, Iowa 52353

Phone: 319-653-2256 Dispatch: 319-653-2107

2024 Activity & Offense Report

For the Month of: August

ACTIVITY	Previous Month	Current Month	Year - to - Date
Calls For Service	568	605	4,096
Animal Calls	34	43	233
Animal Bites	3	0	17
Traffic Citations / Written Warnings	74	80	515
Parking Tickets	3	6	157
Golf Cart Registrations	1	0	19
Vehicle Unlocks	23	27	205
Arrest Warrants Served	11	5	77
Search Warrants Served	1	1	6
Mental Health Crisis	11	22	108
Traffic Stops	152	169	1047
Traffic Accidents	9	17	112
Arrests	48	48	296
Criminal Complaints Filed	37	45	313
Reportable Offenses	68	64	381
Assault	8	4	45
Burglary	0	0	12
Burglary to Motor Vehicle	3	2	8
Domestic Assault	2	6	25
No Contact Order Violation	1	1	11
Criminal Mischief/Vandalism	8	5	41
Drunkenness (Intoxication)	2	5	18
Driving Intoxicated (OWI)	5	3	20
Drug Offense	4	3	31
Drug Paraphernalia	6	3	20
Harassment/Intimidation	1	3	24
Sex Offense	1	0	5
Theft (Includes Shoplifting)	12	14	80
Trespass	2	4	12
Weapons Violation	0	1	2

This chart indicates a summary of the activity and offenses the Washington Police Department responded to during the reporting period. Some activity/offense types have been combined to simplify reporting. It should be noted that an offense does not always result in an arrest. Calls for service do not always include return phone calls, assistance to other agencies and instances where officers are approached while on patrol for minor issues or requests for assistance.

Washington Fire Department
215 East Washington Street
Washington, Iowa 52353
(319) 653-2239 Phone
(319) 653-5273 Fax
www.washingtoniowa.gov



Brendan DeLong- Fire Chief
Bill Hartsock- 1st Asst Fire Chief
Jim Williams- 2nd Asst Fire Chief
Lacie Porter- Asst Chief of EMS

August 2024 Activity Report

Structure fires- 0
Vehicle Fires – 0
Weather related- 0
Mutual aid assists- 0
Hazardous Incidents- 1
Grass fires- 0
Investigate/good intent- 5
Rescue/accidents- 2
Medical- 72

August calls for service- 80

EMS Continues to be busy with 72 calls for service in August. Fire calls were relatively quiet in August, which matches the pattern of previous years. We had one hazardous incident, which was a gas leak in August. The situation was resolved quickly.

August training was held on August 21st. Firefighters trained on car extrication with the help of Professional Rescue Innovations. They are great instructors provided by the Iowa Fire Service Training Bureau at no charge. We also got to demonstrate some new battery powered extrication tools, in hopes of securing some in the future for our new engine.

I attended numerous staff meetings and fire meetings and an EMS Advisory council discussion. This will be a huge benefit if EMS is deemed an essential service in Washington County. If it passes – discussions will begin on how to utilize those funds. Full-time staff continue to be busy responding to EMS & fire calls, fire inspections, and normal duties around the fire station. We plan to burn down the Barthalow farmhouse on October 23rd in the evening. I met with the Asbestos inspector and am in the process of getting everything submitted to the Iowa DNR for approval.

Overall, August was a quiet month, as expected. A lot of our members are on vacation during August with their families, prior to school starting.

A handwritten signature in black ink, appearing to read "Brendan S. DeLong".

Brendan S. DeLong
Fire Chief
Washington Fire Department

January – Aug 2024 Calls for service.

Fire/Rescue calls – 119
Medical calls – 594
Total calls – 713

Library Services Summary: August 2024

Service	August	YTD
<u>Physical Circulation</u>	4,929 (+ 3% Aug 23)	10,514 (+7% YTD)
<u>Digital Circulation</u>	2,066 (+18% Aug 23)	4,064 (+16% YTD)
<u>Total Circulation</u>	6,995 (+7% Aug 23)	14,578 (+9% YTD)
<u>Library Visitors</u>	7,076 (+27% Aug 23)	13,894 (+19% YTD)
<u>Program Attendance</u>	547 (+131% Aug 23)	1,264 (-9% YTD)
<u>New Library Cards</u>	66 (+29% Aug 23)	99 (-21% YTD)
<u>Computer Sessions</u>	704 (+44% Aug 23)	1,594 (+48% YTD)
<u>Wireless Sessions</u>	2,336 (+15% July 23)	4,629 (+11% YTD)
<u>Meeting Rm Hours Used</u>	95.5	197
<u>Active Library Cards</u>	3,623	3,623 (+2.5% July)

August Program/Service Highlights:

- 110 Hours of MakeIT Place use in August by certified users; 22 new certified users were added in August.
- Washington State Bank sponsored the Library's end of Summer Reading Foam Zone celebration in Central Park with over 250 in attendance!

Elm Grove & Woodlawn Cemeteries



Funerals

63 Burials for 2024 as of 9/12/2024, with 34 spaces sold.

Building Maintenance

General Building maintenance and upkeep. New door motors and seals have been installed on the overhead doors in the office building and middle shed.

Yard Work

The SE opening in the Woodlawn fence has been repaired and protected with bollards installed. Mowing, trimming, spraying both cemeteries. Removal of a few trees, watering all young trees weekly. Very limited help this year, really appreciate Rick's continued support of the cemetery.

Kelsey has assisted me in sending letters, with copies of cemetery rules, to families that have abused decoration policies. Currently working with Joe to find a solution.

Equipment Repair/Maintenance

Multiple repairs and maintenance performed on all equipment, done in house.

God Bless America



Zach Wibstad

MAINTENANCE & CONSTRUCTION DEPT. REPORT

8-17-24/8-30-24

STREETS: Personnel poured 24 yards of concrete on South 4th & South 3rd at East Monroe St.

WATER DISTRIBUTION: Personnel repaired number 8,9, 10 & 11 water main breaks of 2024, located at 1600 block of North 3rd Ave, 1200 block of North Iowa Ave and two on West Harrison St between Iowa and Marion. Personnel shut off 11 water services for nonpayment.

SEWER COLLECTION: Personnel installed the 6 inch sewer service for the Soccer field concession at the Wellness Park. Personnel flushed 2,000 gallons of water in the sanitary sewer off of West Buchanan St. Televised in Highland Ct on sewer issues from a resident's request.

STORM SEWER COLLECTION: Personnel checked on a couple of minor issues.

MECHANIC/SHOP: Personnel serviced #111 (wiring issues, changed air lines on bottom of valve and replaced plow lights), #117 (welded on box corner headache rack), PD 713, #144 tank truck (new water pump and temp gauge), PD 852, street sweeper (replaced grease zerk on gutter broom), #305 (rotated tires, installed steering shock and took to Mincer for tranny re-program), FD Engine #1 (changed tarp on hose bed), #630 BackHoe (installed glass window-bottom right front), replaced two LED bay lights and portable air compressor (changed battery).

OTHER: Personnel hauled numerous loads of spoil away. Also hauled a few loads of rock back to the storage building. Personnel responded to 83 One Call locates. The yard waste program continued.

*Please note that this report does not include every task M/C personnel performed, but shall be a highlight of our work performed as a department.

Water Treatment Plant: August 2024 Council Report

9/11/24

Here is a summary of the updates and activities from the Water Treatment Department for August of 2024.

Water Plant Operations: I submitted our July MOR to the DNR. We read water meters, book 7, our extra monthly meter list, all unread meters, and re-reads. We changed 9 water meters in August. We continue to work on changing meters that are not reading. We continue to record LSLI(lead service line inventory) as we are changing meters. Will started logging in the LSLI into the DNR Database. Our goal is to submit it by the end of September, well before the Oct. 16th deadline. We collected our routine monthly bacteria samples and the results were absent. We also collected two bacteria samples for the new water main on S ave B. Those came back absent as well. Bulk chemicals were filled. We recorded our monthly well levels. We changed bag filters. We also changed cartridge filters on RO1 and RO3. We had 3 apartments on the shut off list and all 3 are back on. We continue to work on and implement our backflow prevention ordinance. The fire alarm panel at the water plant is STILL not working. Midwest Alarms has not been great to work with. The South Tower obstruction lighting got fixed. It is back to working as it should be. We had to replace the photodiode and 2 different boards in the panel. A few months back Riverside borrowed some filters from us and they replaced what they borrowed.

Street/Traffic Lights: Jim Conner has completed the programming at Iowa/Madison. That intersection is upgraded and working as it should be. There was a piece of conduit or cable hanging down from the south side of the underpass, Marie Electric fixed it.

Operators: I took some vacation in August. The family and I went to Texas! I also took a vacation day for a golf fundraiser and a concert in KC. Will and I both split up weekend duties. We both try to carry the on-call phone evenly. Will got signed up for Leadership Washington.

Meetings attended: Weekly staff meetings, Mike Roe met with us about the obstruction lighting, Joe Gaa toured the plant and visited with us for a bit, and Will, JJ, Marshal, and myself attended a IAMU training class in Fairfield over LSLI(lead service line inventory).

If you have any questions or concerns, please do not hesitate to contact myself or Will.

Thanks, stay safe!

Kyle Wellington

Water Treatment Superintendent

**WWTP report
September 17th, 2024
Council meeting**

- **After hour alarm and dog call outs –**
8-24-2024 Dog call to 700 block of E 2nd @ 9:25 a.m. Parker
8-26-2024 Generator alarm at WWTP @ 3:00 a.m. Jason
9-05-2024 Dog call to the 400 block of W 3rd @ 11:50 p.m. Parker
9-09-2024 Dog call to 100 block of E 5th @ 4:30 p.m. Parker
- **Dept Head meetings-** August 21st, 27th, September 4th and 11th
- **Hydrogen Sulfide Gas-** We continue to have meetings and conference calls with IRE, NELCO, Fox eng., and City staff to resolve the issue. We have the monitors spread through the sewer system from IRE to the WWTP. We get readings from the monitors once a week, share and go over the information with everyone.
- **WWTP Maintenance-** Routine maintenance was performed on 2 for the decanters 1 blower and 1 raw water pump.
- **Yard Maintenance-** We've been mowing, trimming and spraying the WWTP, Bartholow farm, and lift stations.
- **Wash Press-** Please see the memo and quote for the WWTP wash press repair. Please let me know if you have any questions.
- **Bio-solids 2024-** I will be sending out bids for our 2024 bio-solids land application soon, We will also be doing some annual sludge sampling and testing in the upcoming weeks.
- **WWTP August 2024, Discharge Monitoring Report (DMR) –** Average daily flow **1.02 million gallons (mg)**, maximum daily flow **1.773 mg**, minimum daily flow **0.789 mg**. There were **zero (0)** violations of the WWTP's NPDES discharge permit. Total precipitation for August = **>2.24"** (recorded at the WWTP).

CBOD5 removal 85% required	result = 92.5%
Influent CBOD5 monthly total =	879.3 mg/L
Effluent CBOD5 monthly total =	66.06 mg/L
TSS removal 85% required	result = 98%
Influent TSS monthly total =	1953 mg/L
Effluent TSS monthly total =	39 mg/L

The Plant is Required 85% removal of both CBOD a TSS.

***Due to all Effluent samples being under detection levels the results are counted as 0**

**Jason Whisler
9/12/2024 10:30 A.M.**



Proclamation Domestic Violence Awareness Month October 2024

Whereas, domestic abuse, dating abuse, and stalking affects women, children, and men of all racial, cultural, and economic backgrounds, causing long-term physical, psychological, and emotional harm; and

Whereas, one in three Americans has witnessed an incident of domestic violence; and

Whereas, children who experience domestic abuse are at a higher risk for failure in school, mental illness, substance abuse, suicide, and may choose violence as a way to solve problems later in life; and

Whereas, domestic abuse in rural communities exists as a hidden, silent, and often unrecognized crime that is often underreported; and

Whereas, through the inspiration, courage, and persistence of victims of domestic abuse, their children, and advocates, our communities are learning to recognize the impact of violence in the home and within intimate relationships; and

Whereas, DVIP/RVAP has worked to end violence and abuse in intimate relationships for more than 45 years through the collaborative partnerships of advocates, volunteers, local municipalities, criminal justice, health and human services, faith communities, business leaders, and private citizens; and

Whereas, our community's achievements should be commended and we must continue our commitment to respect and support victims of domestic abuse and to prevent future violence in our community.

Now, therefore, be it resolved that we, the City of Washington, do hereby proclaim the month of October 2024 to be:

Domestic Violence Awareness Month

in the City of Washington, and urge all people to work together to eliminate domestic violence, dating violence, and stalking from our community.

Signed this 17th day of September 2024, in the City of Washington.

Millie Youngquist, Mayor

**CITY OF WASHINGTON, IOWA
CLAIMS REPORT
SEPTEMBER 17, 2024**

POLICE	AMAZON CAPITAL SERVICES	OFFICE SUPPLIES/TASER/BATTERIES	296.78	
	BDH TECHNOLOGY LLC	TECH SERVICES/IT CONTRACT	1,311.00	
	CRITICAL HIRE	NEW HIRE TESTING	175.00	
	EASTERN IOWA CHIROPRACTIC CENTRE, PC	NEW HIRE SCREENING	165.00	
	GALLS LLC	UNIFORMS-NEW HIRE/BADGES	577.19	
	IOWA PRISON INDUSTRIES	ILEA TRAINING UNIFORMS	460.00	
	KCTC	PHONE & INTERNET	199.36	
	SIRCHIE ACQUISITION COMPANY	EVIDENCE SUPPLIES	38.08	
	VERIZON WIRELESS	WIRELESS SERVICE	1,015.41	
		TOTAL	4,237.82	
	FIRE	ALL AMERICAN PEST CONTROL	PEST CONTROL	42.50
		BEAUCHAMP, TOM	MILEAGE REIMBURSEMENT	149.34
		CINTAS CORP LOC. 342	TOWEL SERVICE	118.39
		KCTC	PHONE & INTERNET	153.02
		TOTAL	463.25	
DEVELOPMENT SERV	ACE-N-MORE	SUPPLIES	17.99	
	FARRIER, KELLY	BRUSH CLEANUP	235.00	
	VERIZON WIRELESS	WIRELESS SERVICE	132.93	
	WASHINGTON DISPOSAL LLC.	NUISANCE PICKUP	150.00	
		TOTAL	535.92	
LIBRARY	ACE-N-MORE	JANITORIAL SUPPLIES	40.57	
	ALL AMERICAN PEST CONTROL	PEST CONTROL	40.00	
	ALLIANT ENERGY	ALLIANT ENERGY	2,865.40	
	AMAZON CAPITAL SERVICES	LIBRARY MATERIALS	230.08	
	BAKER & TAYLOR	LIBRARY MATERIALS	979.69	
	DEMCO INC	OFFICE SUPPLIES	79.20	
	HGTV MAGAZINE	SUBSCRIPTION	29.97	
	MIDWEST ALARM	SERVICE CALL, SMOKE DETECT	392.25	
	MILLER, NATALI	LIBRARY PROG MACRAME WORKS	130.00	
	STAPLES BUSINESS ADVANTAGE	OFFICE SUPPLIES	110.57	
	TASTE OF HOME	SUBSCRIPTION	13.91	
	VALENTINE, TAMMY	HOMEBOUND DELIVERY-REIMB	7.21	
	WOMAN'S DAY	SUBSCRIPTION	10.00	
		TOTAL	4,928.85	
	PARKS	ACE-N-MORE	SUPPLIES	82.70
		ALLIANT ENERGY	ALLIANT ENERGY	1,575.96
		KCTC	PHONE & INTERNET	340.21
MID-AM RES. CHEMICAL CORP		WEED KILLER AND OIL	388.93	
VERIZON WIRELESS		WIRELESS SERVICE	80.02	
		TOTAL	2,467.82	
POOL	ALLIANT ENERGY	ALLIANT ENERGY	2,663.37	
	KCTC	PHONE & INTERNET	85.94	
	STATE HYGIENIC LAB	LAB TESTING	14.50	
		TOTAL	2,763.81	

CEMETERY

ACE-N-MORE	RODENT CONTROL SUPPLIES	62.86
ARNOLD MOTOR SUPPLY	OIL SEAL	10.29
CJ COOPER & ASSOC.	EMPLOYEE SCREENINGS	50.00
EASTERN IOWA CHIROPRACTIC CENTRE, PC	EMPLOYEE SCREENINGS	45.00
HAWKEYE FIRE & SAFETY	FIRE EXTINGUISHER SERVICE	87.00
KCTC	PHONE & INTERNET	120.28
MID-AM RES. CHEMICAL CORP	WEED KILLER AND OIL	388.93
VERIZON WIRELESS	WIRELESS SERVICE	99.39
WASHINGTON CO EXTENSION	SPRAY APPLICATOR CLASSES	90.00
	TOTAL	953.75

FINANCIAL ADMIN

ALBERT, KIRK	MILEAGE REIMBURSEMENT	104.15
ALL AMERICAN PEST CONTROL	PEST CONTROL	42.50
ALLIANT ENERGY	ALLIANT ENERGY	24.21
CINTAS CORP LOC. 342	RUG SERVICE	65.50
GAA, JOE	MOVING EXPENSES	3,806.75
GOOGLE LLC	EMAIL SUBSCRIPTION	395.99
IAMU - IA ASSOC MUNICIPAL UTILITIES	QTR 3 SAFETY TRAINING	1,740.00
IGRAPHIX, INC	ENVELOPES	1,102.00
IMFOA	CONFERENCE - BROWN	150.00
KCTC	PHONE & INTERNET	1,129.15
VERIZON WIRELESS	WIRELESS SERVICE	40.01
WASH CO RECORDER	RECORDING FEE	22.00
WASH COUNTY MINIBUS	LOST- SEPTEMBER	26,824.72
WMPF GROUP LLC	LEGAL ADVERTISING	1,129.12
	TOTAL	36,576.10

AIRPORT

AIRNAV, LLC	ADVERTISING PUBLICATION	122.00
BAUTISTA MIRANDA, YOLANDA	AUGUST CLEANING	300.00
UNIFIED CONTRACTING SERVICES	FUEL TANK REPAIR	8,294.56
VERIZON WIRELESS	WIRELESS SERVICE	46.46
VETTER'S INC-CULLIGAN WATER	WATER FOR AIRPORT	44.95
WEST LAWN CARE	AIRPORT MOWING	3,020.00
WINDSTREAM IOWA COMMUNICATIONS	SEPTEMBER SERVICE	215.13
	TOTAL	12,043.10

ROAD USE

CJ COOPER & ASSOC.	EMPLOYEE SCREENINGS	100.00
COBB OIL CO., INC-BP ONE TRIP	FUEL	105.33
COLEMAN CONSTRUCTION INC.	SIDEWALK REPAIR	1,674.70
DOUDS STONE LLC	ROADSTONE	348.75
EASTERN IOWA CHIROPRACTIC CENTRE, PC	EMPLOYEE SCREENING	90.00
IOWA PRISON INDUSTRIES	SIGNS	234.96
LYNCH DALLAS, PC.	PROF. SERVICES	360.00
MID-AM RES. CHEMICAL CORP	WEED KILLER AND OIL	388.93
NESPER SIGN	SIGN INSTALLATION	2,445.90
RUSSO DIAMOND SUPPLY LLC	BLADES FOR GRINDER	628.00
WASHINGTON LUMBER	CRACK SEALER/PATCHING MATERIALS	322.89
	TOTAL	6,699.46

STREET LIGHTING

ALLIANT ENERGY	ALLIANT ENERGY	12,535.79
J MARIE ELECTRIC LLC	STOP LIGHT REPAIR	449.99
	TOTAL	12,985.78

LOST DEBT SERVICE	UMB BANK, N.A.	GO BOND FEE	600.00
		TOTAL	600.00
HOUSING REHABILITA	WASH CO TREASURER	320 M AVE C-PROP TAX	142.00
		320 N AVE C- N LOT-PROP TA	61.00
		TOTAL	203.00
CAPITAL PROJECTS	PAY.GOV - FAA REIMBURSABLE AGREEMENTS	FLIGHT INSPECTION-AMEND	14,419.84
		TOTAL	14,419.84
INDUSTRIAL DEVELOP	WASH CO TREASURER	BUSINESS PARK TAXES	2,861.00
	WEDG	915 E TYLER- WEDG SHARE	4,298.88
		TOTAL	7,159.88
RESIDENTIAL DEVELOP	WASH CO TREASURER	BELL LAND PROP TAX	433.00
		TOTAL	433.00
LIBRARY GIFT	ANDERSEN, ROBERT	POTTERY CLASS	161.76
	JB FRAME & DESIGN	FRAME REPAIR	279.79
	KCTC	REPLACE WAP	300.60
	RAINEY, CALEB	WRITER'S WORKSHOP	1,750.00
	RENTERIA, JESUS	LIBRARY PROGRAMMING	200.00
		TOTAL	2,692.15
WATER PLANT	ALLIANT ENERGY	ALLIANT ENERGY	15,348.13
	ACE-N-MORE	SUPPLIES	90.94
	GLOBAL PAYMENTS	DC/CC ADMIN FEE	5,400.21
	HAWKEYE FIRE & SAFETY	FIRE EXTINGUISHER SERVICE	70.00
	HOLLAND, EVAN	WATER DEPOSIT REFUND	107.23
	IA DEPT OF REVENUE	WET TAX	9,821.16
	IAMU - IA ASSOC MUNICIPAL UTILITIES	WATER MEMBER DUES	1,117.00
	INEICHEN, STEPHANIE	WATER DEPOSIT REFUND	25.03
	ION ENVIRONMENTAL SOLUTIONS	LAB SERVICES	180.00
	KCTC	PHONE & INTERNET	158.67
	KLEIN ELECTRICAL SERVICES	WATER TOWER LIGHT SERVICE	500.00
	MISCELLANEOUS V NELSON, HALEY	WATER DEPOSIT REFUND	99.96
	SPX AIDS TO NAVIGATION	PARTS FOR WATER PLANT	520.33
	STATE HYGIENIC LAB	LAB TESTING	137.50
	VALLE CHAVEZ, GABRIE	WATER DEPOSIT REFUND	104.71
	VERIZON WIRELESS	WIRELESS SERVICE	46.46
	WATER SOLUTIONS UNLIMITED	CHEMICALS	10,722.96
	WHEELER, KELBY	WATER DEPOSIT REFUND	65.53
	ZEHR, MIKE	WATER DEPOSIT REFUND	206.34
		TOTAL	44,722.16
WATER DISTRIBUTION	ALLIANT ENERGY	ALLIANT ENERGY	30.30
	CINTAS FIRST AID & SAFETY	FIRST AID SUPPLIES	121.68
	CRAWFORD, BRICE	BOOT REIMBURSMET	100.00
	IDEAL READY MIX	CONCRETE REPAIR/S 3RD & MO	5,698.50

KCTC	PHONE & INTERNET	104.31
KUENSTER PLUMBING, HEATING & AIR	GAS LEAK REPAIRS	3,170.42
MID-AM RES. CHEMICAL CORP	WEED KILLER AND OIL/SHOP TOWELS	586.49
RIVER PRODUCTS	CONCRETE SAND	493.00
VERIZON WIRELESS	WIRELESS SERVICE	46.46
	TOTAL	10,351.16

SEWER PLANT

ALL AMERICAN PEST CONTROL	PEST CONTROL	35.00
ALLIANT ENERGY	ALLIANT ENERGY	318.79
CINTAS FIRST AID & SAFETY	FIRST AID SUPPLIES	93.95
EUROFINS ENVIRONMENT TESTING NC	CERTIFIED TESTING	1,801.88
HAWKEYE FIRE & SAFETY	FIRE EXTINGUISHER SERVICE	150.00
IA DEPT OF REVENUE	SALES TAX	2,373.11
JOHN DEERE FINANCIAL	MOWER BLADES	28.33
KCTC	PHONE & INTERNET	198.62
MID-AM RES. CHEMICAL CORP	ENZYMES FOR TREATMENT	1,348.63
TRACTOR SUPPLY	PARTS FOR REPAIRS/SUMP PUMP	470.97
VERIZON WIRELESS	WIRELESS SERVICE	92.92
WINDSTREAM IOWA COMMUNICATIONS	SEPTEMBER SERVICE	67.41
	TOTAL	6,979.61

SEWER COLLECTION

ALLIANT ENERGY	ALLIANT ENERGY	1,147.72
CHEMSEARCH FE	SUPPLIES	369.90
IOWA ONE CALL	SERVICE	163.80
KCTC	PHONE & INTERNET	104.31
MIDWEST WHEEL	SHOP SUPPLIES	70.50
MINCER FORD	REPAIR	132.50
VERIZON WIRELESS	WIRELESS SERVICE	38.01
	TOTAL	2,026.74

SANITATION

ABC DISPOSAL SYSTEMS	GARBAGE AND RECYCLING SERV	53,133.00
	TOTAL	53,133.00

SELF INSURANCE

EMPLOYEE BENEFIT SYSTEMS	EBS ADMIN FEE	364.64
	TOTAL	364.64

TOTAL	227,740.84
--------------	-------------------

CITY OF WASHINGTON, IOWA
MONTH TO DATE TREASURERS REPORT
JULY 31, 2024

FUND	7/1/2024	M-T-D	REVENUES NOT	M-T-D	EXPENSES NOT	7/31/2024
	BEGINNING					REVENUES
	CASH BALANCE					BALANCE
001-GENERAL FUND	1,000,000.00	100,522.51	-	443,076.34	-	657,446.17
002-AIRPORT FUND	387,734.94	76,233.55	-	6,720.14	-	457,248.35
010-CHAMBER REIMBURSEMENT	3,262.44	-	-	10,717.06	-	(7,454.62)
011-MAIN STREET REIMBURSEMENT	472.15	4,701.65	-	4,112.39	-	1,061.41
012-WEDG REIMBURSEMENT	4,835.72	9,573.26	-	8,874.78	-	5,534.20
050-DOWNTOWN INCENTIVE GRANT	231,473.15	-	-	-	-	231,473.15
110-ROAD USE	620,246.57	84,221.51	-	165,811.61	-	538,656.47
112-EMPLOYEE BENEFITS	-	4,667.38	-	4,667.38	-	-
113-LIABILITY INSURANCE	-	-	-	-	-	-
114-EMERGENCY LEVY	-	351.90	-	351.90	-	-
121-LOCAL OPTION SALES TAX	-	117,010.46	-	117,010.46	-	-
122-LOST DEBT SERVICE	-	87,757.84	-	-	-	87,757.84
123-LOST DEBT SERVICE RESERVE	79,170.00	-	-	-	-	79,170.00
124-HOTEL/MOTEL TAX	120,681.62	9,914.38	-	8,761.20	-	121,834.80
125-UNIF COMM UR-NE IND	-	-	-	-	-	-
126-SE RES UR	-	-	-	-	-	-
127-UNIF COMM UR - BRIARWOOD	-	-	-	-	-	-
128-URBAN RENEWAL AREA #3B/D	-	-	-	-	-	-
129-SC RES UR	-	-	-	-	-	-
130-URBAN RENEWAL AREA #3D	-	-	-	-	-	-
131-URBAN RENEWAL AREA #4	-	-	-	-	-	-
132-UNIF COMM UR - EBD	-	-	-	-	-	-
133-UNIF COMM UR-IRE	-	-	-	-	-	-
134-DOWNTOWN COMM UR	-	-	-	-	-	-
145-HOUSING REHABILITATION	-	(46,483.32)	-	31,725.00	-	(78,208.32)
146-LMI TIF SET-ASIDE	37,334.88	-	-	(46,483.32)	-	83,818.20
200-DEBT SERVICE	24,845.68	4,796.97	-	-	-	29,642.65
300-CAPITAL EQUIPMENT	910,654.02	5,752.09	-	86,474.60	-	829,931.51
301-CAPITAL PROJECTS FUND	374,940.02	14,955.60	-	167,742.98	-	222,152.64
303-WWTP CAPITAL PROJ FUND	-	-	-	-	-	-
305-RIVERBOAT FOUND CAP PROJ	822,830.08	-	-	(85,019.10)	-	907,849.18
308-INDUSTRIAL DEVELOPMENT	519,625.13	9,349.13	-	9,526.08	-	519,448.18
309-MUNICIPAL BUILDING	-	-	-	-	-	-
310-WELLNESS PARK	-	(85,019.10)	-	150.00	-	(85,169.10)
311-SIDEWALK REPAIR & REPLACE	120,578.86	1,089.00	-	128.00	-	121,539.86
312-TREE REMOVAL & REPLACE	15,648.59	-	-	525.00	-	15,123.59
315-RESIDENTIAL DEVELOPMENT	513,765.90	154.80	-	-	-	513,920.70
317-ARPA CAPITAL PROJECTS	226,091.67	2,355.91	-	-	-	228,447.58
325-BUILDING & FACILITY MAINT	120,824.39	-	-	-	-	120,824.39
510-MUNICIPAL BAND	12,106.96	-	-	-	-	12,106.96
520-DOG PARK	3,575.87	-	-	-	-	3,575.87
530-TREE COMMITTEE	20,038.29	-	-	-	-	20,038.29
535-NEIGHBORHOOD PRIDE	-	-	-	-	-	-
540-POLICE FORFEITURE	3,631.25	-	-	-	-	3,631.25
541-K-9 PROGRAM	4,499.73	50.00	-	40.75	-	4,508.98
545-SAFETY FUND	5,028.73	1,000.00	-	-	-	6,028.73
550-PARK GIFT	47,414.86	120.00	-	-	-	47,534.86
570-LIBRARY GIFT	75,624.89	1,270.76	-	2,331.46	-	74,564.19
580-CEMETERY GIFT	1,968.00	-	-	-	-	1,968.00
590-CABLE COMMISSION	-	-	-	-	-	-
600-WATER UTILITY	490,805.38	202,624.59	-	162,130.23	-	531,299.74
601-WATER DEPOSIT FUND	33,605.00	1,200.00	-	1,725.00	-	33,080.00
602-WATER SINKING	-	-	-	-	-	-
603-WATER CAPITAL PROJECTS	475,026.40	-	-	13,832.72	-	461,193.68
610-SANITARY SEWER	889,421.83	210,837.65	-	77,745.66	-	1,022,513.82
612-SEWER SINKING	-	-	-	-	-	-
613-SEWER CAPITAL PROJECTS	-	-	-	-	-	-
670-SANITATION	213,672.82	60,462.60	-	642.31	-	273,493.11
910-LIBRARY TRUST	-	-	-	-	-	-
950-SELF INSURANCE	612,974.65	419.13	-	3,893.45	-	609,500.33
951-UNEMPLOYMENT SELF INS	89,579.14	5.13	-	-	-	89,584.27
TOTAL BALANCE	9,113,989.61	879,895.38	-	1,197,214.08	-	8,796,670.91

Cash in Bank - Pooled Cash

		Interest Rate
Wash St. Bank - Operating Account	804,567.53 (1)	0.20%
Wash St. Bank - Airport Fuel Account	-	
Cash in Drawer	350.00	N/A
Investment in IPAIT	1,114,031.32	0.20%
Wash St - Farm Mgmt Acct	209,190.17	
Wash St Bank - CD 1/14/2019	534,781.23	0.65%
Wash St Bank - CD 08/30/2018	274,977.69	0.65%
Wash St Bank - ISC Account	4,359,355.41	4.25%
IPAIT CD-3 Month 5/22/24	1,499,417.56	5.25%
TOTAL CASH IN BANK	8,796,670.91	

(1) Washington State Bank
Outstanding Deposits & Checks/Wages payable
804,567.53

CITY OF WASHINGTON, IOWA
YEAR TO DATE TREASURERS REPORT
JULY 31, 2024

FUND	7/1/2024	Y-T-D	REVENUES NOT	Y-T-D	EXPENSES NOT	7/31/2024
	BEGINNING					REVENUES
	CASH BALANCE					BALANCE
001-GENERAL FUND	1,000,000.00	100,522.51	-	443,076.34	-	657,446.17
002-AIRPORT FUND	387,734.94	76,233.55	-	6,720.14	-	457,248.35
010-CHAMBER REIMBURSEMENT	3,262.44	-	-	10,717.06	-	(7,454.62)
011-MAIN STREET REIMBURSEMENT	472.15	4,701.65	-	4,112.39	-	1,061.41
012-WEDG REIMBURSEMENT	4,835.72	9,573.26	-	8,874.78	-	5,534.20
050-DOWNTOWN INCENTIVE GRANT	231,473.15	-	-	-	-	231,473.15
110-ROAD USE	620,246.57	84,221.51	-	165,811.61	-	538,656.47
112-EMPLOYEE BENEFITS	-	4,667.38	-	4,667.38	-	-
113-LIABILITY INSURANCE	-	-	-	-	-	-
114-EMERGENCY LEVY	-	351.90	-	351.90	-	-
121-LOCAL OPTION SALES TAX	-	117,010.46	-	117,010.46	-	-
122-LOST DEBT SERVICE	-	87,757.84	-	-	-	87,757.84
123-LOST DEBT SERVICE RESERVE	79,170.00	-	-	-	-	79,170.00
124-HOTEL/MOTEL TAX	120,681.62	9,914.38	-	8,761.20	-	121,834.80
125-UNIF COMM UR-NE IND	-	-	-	-	-	-
126-SE RES UR	-	-	-	-	-	-
127-UNIF COMM UR - BRIARWOOD	-	-	-	-	-	-
128-URBAN RENEWAL AREA #3B/D	-	-	-	-	-	-
129-SC RES UR	-	-	-	-	-	-
130-URBAN RENEWAL AREA #3D	-	-	-	-	-	-
131-URBAN RENEWAL AREA #4	-	-	-	-	-	-
132-UNIF COMM UR - EBD	-	-	-	-	-	-
133-UNIF COMM UR-IRE	-	-	-	-	-	-
134-DOWNTOWN COMM UR	-	-	-	-	-	-
145-HOUSING REHABILITATION	-	(46,483.32)	-	31,725.00	-	(78,208.32)
146-LMI TIF SET-ASIDE	37,334.88	-	-	(46,483.32)	-	83,818.20
200-DEBT SERVICE	24,845.68	4,796.97	-	-	-	29,642.65
300-CAPITAL EQUIPMENT	910,654.02	5,752.09	-	86,474.60	-	829,931.51
301-CAPITAL PROJECTS FUND	374,940.02	14,955.60	-	167,742.98	-	222,152.64
303-WWTP CAPITAL PROJ FUND	-	-	-	-	-	-
305-RIVERBOAT FOUND CAP PROJ	822,830.08	-	-	(85,019.10)	-	907,849.18
308-INDUSTRIAL DEVELOPMENT	519,625.13	9,349.13	-	9,526.08	-	519,448.18
309-MUNICIPAL BUILDING	-	-	-	-	-	-
310-WELLNESS PARK	-	(85,019.10)	-	150.00	-	(85,169.10)
311-SIDEWALK REPAIR & REPLACE	120,578.86	1,089.00	-	128.00	-	121,539.86
312-TREE REMOVAL & REPLACE	15,648.59	-	-	525.00	-	15,123.59
315-RESIDENTIAL DEVELOPMENT	513,765.90	154.80	-	-	-	513,920.70
317-ARPA CAPITAL PROJECTS	226,091.67	2,355.91	-	-	-	228,447.58
325-BUILDING & FACILITY MAINT	120,824.39	-	-	-	-	120,824.39
510-MUNICIPAL BAND	12,106.96	-	-	-	-	12,106.96
520-DOG PARK	3,575.87	-	-	-	-	3,575.87
530-TREE COMMITTEE	20,038.29	-	-	-	-	20,038.29
535-NEIGHBORHOOD PRIDE	-	-	-	-	-	-
540-POLICE FORFEITURE	3,631.25	-	-	-	-	3,631.25
541-K-9 PROGRAM	4,499.73	50.00	-	40.75	-	4,508.98
545-SAFETY FUND	5,028.73	1,000.00	-	-	-	6,028.73
550-PARK GIFT	47,414.86	120.00	-	-	-	47,534.86
570-LIBRARY GIFT	75,624.89	1,270.76	-	2,331.46	-	74,564.19
580-CEMETERY GIFT	1,968.00	-	-	-	-	1,968.00
590-CABLE COMMISSION	-	-	-	-	-	-
600-WATER UTILITY	490,805.38	202,624.59	-	162,130.23	-	531,299.74
601-WATER DEPOSIT FUND	33,605.00	1,200.00	-	1,725.00	-	33,080.00
602-WATER SINKING	-	-	-	-	-	-
603-WATER CAPITAL PROJECTS	475,026.40	-	-	13,832.72	-	461,193.68
610-SANITARY SEWER	889,421.83	210,837.65	-	77,745.66	-	1,022,513.82
612-SEWER SINKING	-	-	-	-	-	-
613-SEWER CAPITAL PROJECTS	-	-	-	-	-	-
670-SANITATION	213,672.82	60,462.60	-	642.31	-	273,493.11
910-LIBRARY TRUST	-	-	-	-	-	-
950-SELF INSURANCE	612,974.65	419.13	-	3,893.45	-	609,500.33
951-UNEMPLOYMENT SELF INS	89,579.14	5.13	-	-	-	89,584.27
TOTAL BALANCE	9,113,989.61	879,895.38	-	1,197,214.08	-	8,796,670.91

Cash in Bank - Pooled Cash

		Interest Rate
Wash St. Bank - Operating Account	804,567.53 (1)	0.20%
Wash St. Bank - Airport Fuel Account	-	-
Cash in Drawer	350.00	N/A
Investment in IPAIT	1,114,031.32	0.20%
Wash St - Farm Mgmt Acct	209,190.17	-
Wash St Bank - CD 1/14/2019	534,781.23	0.65%
Wash St Bank - CD 08/30/2018	274,977.69	0.65%
Wash St Bank - ISC Account	4,359,355.41	4.25%
IPAIT CD-3 Month 5/22/24	1,499,417.56	5.25%
TOTAL CASH IN BANK	8,796,670.91	

(1) Washington State Bank	904,151.15
Outstanding Deposits & Checks/Wages payable	(99,583.62)
	<u>804,567.53</u>



*Millie Youngquist, Mayor
Joe Gaa, City Administrator
Kelsey Brown, Finance Director
Kevin Olson, City Attorney*

*City of Washington
215 East Washington Street
Washington, Iowa 52353
(319) 653-6584 Phone
(319) 653-5273 Fax*

MEMORANDUM

TO: Mayor and City Council

FROM: Joe Gaa, City Administrator 

DATE: September 12, 2024

SUBJECT: Alley Vacation- Public Hearing and First Reading of Ordinance

At an August 13th meeting the Planning and Zoning Commission approved forwarding a recommendation to the City Council to vacate and dispose of a street/alley. North Third Avenue currently dead ends in Alliant Energy's parking lot and has basically become part of the parking lot. The street joins an alley that extends to the east.

The recommendation from the P&Z Commission is to vacate the portions of 3rd Avenue and the alley that are bordered by Alliant Energy's property on both sides (Alliant now owns the vacant lots). Please see the attached map.

At the September 17th meeting a Public Hearing has been set to discuss the matter. A new business item for approval of the first reading of an ordinance approving the vacation and disposal is also an agenda item.

If you have any questions or comments regarding this matter, feel free to contact me at your convenience.

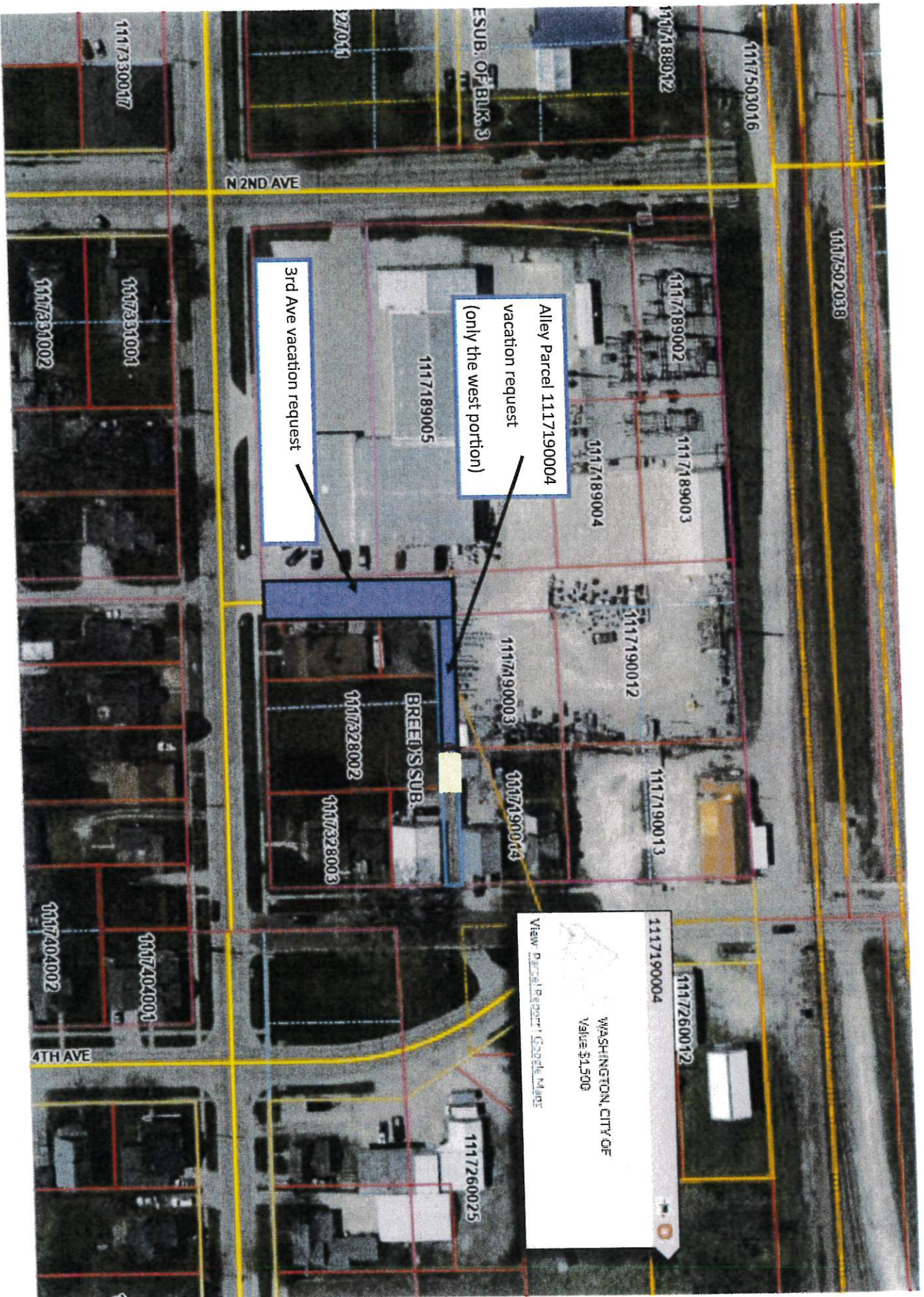

1117502038

1117503016

1117188012

1117189002

1117189003

1117189004

1117190012

1117190013

1117190003

1117190014

1117190004

1117260012

1117260025

ESUB. OF BUR. 3

111727011

N 2ND AVE

1117189005

3rd Ave vacation request

BREED'S SUB.

1117328002

1117328003

1117330017

1117331001

1117331002

1117401001

1117401002

4TH AVE

View Parcel Report | Google Maps

1117190004

WASHINGTON, CITY OF

VALUE \$1,500

Prepared by: Kevin D. Olson, Washington City Attorney, PO Box 5640, Coralville, Iowa 52241 (319)351-2277
Return to: Washington City Clerk, 215 E. Washington Street, Washington, Iowa 52353.

ORDINANCE NO. _____

AN ORDINANCE VACATING A PORTION OF N. 3RD AVENUE AND A PORTION OF THAT EAST-WEST ALLEY IDENTIFIED AS WASHINGTON COUNTY PARCEL NO. 1117190004.

WHEREAS, the City Council of the City of Washington has been requested by an adjacent property owner to vacate a portion of N. 3rd Avenue located north of E. 3rd Street and a portion of the east-west alley identified as Washington County Parcel No. 1117190004 (the "Parcels"); and

WHEREAS, the Parcels to be vacated are legally described as follows:

All that portion of N. 3rd Avenue located north of E. 3rd Street northerly to the previously vacated portion of N. 3rd Avenue; AND

That portion of Washington County Parcel 1117190004 from its intersection with N. 3rd Avenue westerly to the westerly line of Lot One (1) in Breed's Sub-Division of Lot Five (5) in Block One (1) in the North Addition to the City of Washington, Iowa

WHEREAS, the excess right-of-way is of no use to the City, and should be returned to the tax rolls.

NOW, THEREFORE, BE IT ORDAINED, as follows:

1. Vacation. That the rights-of-way described herein as the Parcels, is hereby vacated.

2. Quit Claim Deed. That upon the passage of this Ordinance, the Mayor and City Clerk will execute a Quit Claim Deed to Interstate Power and Light Company as the owner of the adjacent properties to the Parcels.

3. Repealer. All ordinances or parts of ordinances in conflict with the provisions of this Ordinance are hereby repealed.

4. Effective Date. This Ordinance shall be in effect after its final passage, approval and publication as provided by law.

Passed and approved this _____ day of _____, 2024.

Millie Youngquist, Mayor

Attest:

Kelsey Brown, Deputy City Clerk

Approved on First Reading: _____

Approved on Second Reading: _____

Approved on Third & Final Reading: _____

I certify that the foregoing was published as Ordinance No. _____ on the _____ day of _____, 2015.

City Clerk



Millie Youngquist, Mayor
Joe Gaa, City Administrator
Kelsey Brown, Finance Director
Kevin Olson, City Attorney

City of Washington
215 East Washington Street
Washington, Iowa 52353
(319) 653-6584 Phone
(319) 653-5273 Fax

WWTP MEMORANDUM

To: City council, Mayor, and City Administrator

From: Jason Whisler Waste Water Superintendent

Subject: Wash press auger replacement

Date: Tuesday September 10th, 2024

We replaced the brush on the wash press auger last year. When doing so we discovered a crack in the auger and other wear on the auger. We added money to the Plants repair and maintenance budget line for this. I'm asking for approval for the replacement parts of \$10,543.00 money available for in account 610-6-8015-6350 please see attached quote.

If you have any questions or need additional information, please let me know.

Thank you

Jason Whisler



City of Washington
215 E. Washington St.
Washington, IA 52353

Dear City Councilors,

I am reaching out to you to inform you that the Delongs have nearly completed their Downtown Investment Grant project. The project thus far has totaled \$167,442 which has been paid (see attachments & pictures) far exceeding their required minimum of \$100,000. The exterior work is scheduled to begin in the coming weeks. This phase will involve removing the existing iron cladding, repainting it black, and framing it to accommodate a new black fabric awning. This final step will enhance the building's aesthetic and unify the overall style of Lux Suites.

I am requesting that the City of Washington issues payment of **\$25,000** to complete this DIG project awarded in 2024.

Thank you very much. If you have any questions please let me know.

Sincerely,

Samantha Meyer
Executive Director
Main Street Washington



Renoux Builders, Inc
 2695 Airport Rd
 Washington, IA 52353
 319-653-8039
 renouxbuilders@hotmail.com

Invoice

Date	Invoice #
5/15/2024	2006-1771

Bill To

Brendan Delong
 110 E Main
 Washington, IA 52353

P.O. No.	Terms	Due Date	Account #	Project
		5/22/2024		
Description		Qty	Rate	Amount
Labor and material for work done up to 5/1/2024 on LUX Suites. Includes plumbing but no electrical or HVAC			83,305.28	83,305.28
Pd ✓ #1017 6/4/24				
Total				\$83,305.28
Payments/Credits				\$0.00
Balance Due				\$83,305.28



Renoux Builders, Inc
2695 Airport Rd
Washington, IA 52353
319-653-8039
renouxbuilders@hotmail.com

Invoice

Date	Invoice #
7/2/2024	2006-1781

Bill To

Brendan DeLong
110 E Main
Washington, IA 52353

P.O. No.	Terms	Due Date	Account #	Project
		7/2/2024		
Description		Qty	Rate	Amount
Labor and material for work done from 6/1/24-7/1/24 Includes electrical and HVAC.			73,827.46	73,827.46
<i>Pd 1022</i> <i>VH 1022</i> <i>8/26/24</i>				
Total				\$73,827.46
Payments/Credits				\$0.00
Balance Due				\$73,827.46



Renoux Builders, Inc
 2695 Airport Rd
 Washington, IA 52353
 319-653-8039
 renouxbuilders@hotmail.com

Invoice

Date	Invoice #
8/12/2024	2006-1792

Bill To

Brendan Delong
 110 E Main
 Washington, IA 52353

P.O. No.	Terms	Due Date	Account #	Project
		8/19/2024		
Description		Qty	Rate	Amount
Labor and material for work done on Lux 7/1/24-8/1/24			10,112.44	10,112.44 <i>2120</i>
Rough cost of extras				
Widen door way in back-----\$500				
Install rubber sound proofing-----\$800				
Door between 2 sides-----\$800				
Quartz top-----\$2800				
Glass above doors-----\$4000				
Door Upgrade-----\$7000				
Electrical-----\$6000				
Hvac				
upgrade-----\$5000				
Trim upgrade-----3500				
Ceiling Black-----\$1000				
Tile bathroom and back splash-----\$800				
Refinish				
floor-----\$17,500				
Plumbing fixture upgrade-----\$1000				
Insulate				
floor-----\$2500				
Total			\$10,112.44	
Payments/Credits			\$0.00	
Balance Due			\$10,112.44	

*pd 1029
 V#1029
 8/26/24*

10792.44





From back of Lux

From Lux entry



Restrooms & connecting door



From Earthly Blessing entry



Back 3 suites

RESOLUTION NO. 2024-

**A RESOLUTION RELEASING FUNDS AS PER A DOWNTOWN INVESTMENT
GRANT AGREEMENT WITH LUX SUITES FOR THE RENOVATION OF 110 WEST
MAIN STREET**

WHEREAS, the City Council awarded LUX Suites a forgivable loan of \$25,000 for building improvements at 110 West Main Street, on April 2, 2024 under the Downtown Investment Grants (DIG) program; and,

WHEREAS, the project at 110 West Main Street has been substantially completed as promised, and the developer has provided acceptable documentation of eligible expenses incurred.

NOW, THEREFORE, BE IT RESOLVED BY THE CITY COUNCIL OF THE CITY OF WASHINGTON, IOWA:

Section 1. The City Council hereby authorizes release of \$25,000 to LUX Suites for the renovation project under the DIG program.

Section 2. The Developer has signed a Memorandum of Understanding per the Downtown Investment Grant Agreement as a lien against the property under DIG guidelines and the agreement has been recorded.

Section 3. All Resolutions or parts of Resolution in conflict herewith are hereby repealed to the extent of such conflict.

PASSED AND APPROVED this 13th day of September, 2024

Millie Youngquist, Mayor

ATTEST:

Kelsey Brown, Deputy City Clerk



Millie Youngquist, Mayor
Joe Gaa, City Administrator
Kelsey Brown, Finance Director
Kevin Olson, City Attorney

City of Washington
215 East Washington Street
Washington, Iowa 52353
(319) 653-6584 Phone
(319) 653-5273 Fax

MEMORANDUM

TO: Mayor and City Council

FROM: Joe Gaa, City Administrator 

DATE: September 13, 2024

SUBJECT: Resolution to Set Public Hearing for Central Park Restroom Project

An item has been placed on the September 17th Council meeting agenda to approve a resolution that would set a public hearing to consider bids for the Central Park Restroom Project. On the 17th the Council will review the preliminary plans, specifications and cost estimates. The project will then be released for bidding. The bids will be opened on October 17th. The public hearing to review and consider the bids will be at a Special Meeting on October 22nd. Once a bid is accepted, contracts, insurance, and bonds will be finalized and a notice to proceed issued in early November. The final completion date for the project will be May 23, 2025.

This is a great project that will add to the appeal of Central Park, the location of many community events. If you have any questions or comments regarding this matter, feel free to contact me at your convenience.

PUBLIC HEARING NOTICE

The City of Washington, Iowa, is hereby serving as Public Notice that on October 22, 2024, at 6:00 p.m., the City Council will hold a public hearing in the Council Chambers at City Hall to consider bids for the Central Park Restroom Project.

This meeting will be held to give residents information concerning the proposed project. Citizens are encouraged to attend and express their preferences about the proposed activities. Anyone having questions about this project or the upcoming hearing may call the City Clerk at 319-653-6584.

Kelsey Brown
Deputy City Clerk
City of Washington, Iowa

SCHEDULE

FOR

CENTRAL PARK RESTROOM RECONSTRUCTION

WASHINGTON, IOWA

September 17, 2024:	Approve Plans & Specifications Set Public Hearing Date and Bid Date
September 18, 2024:	Plans and Specifications Available Post Notice to Bidders
October 14, 2024:	Publish Notice of Public Hearing (week of)
October 17, 2024:	Receive Bids for Project
October 22, 2024:	Public Hearing & Award Contract
November 20, 2024:	Notice to Proceed
May 23, 2025:	Final Completion

Central Park Restrooms
 Washington, Iowa
 September 13, 2024



Work to be bid

ITEM No.	Description	Unit	Estimated Quantities	Unit Price	Extended Price
1	Concession Stand	LS	1	\$ 200,000.00	\$ 200,000.00

Total \$ 220,000.00

Work by City

ITEM No.	Description	Unit	Estimated Quantities	Unit Price	Extended Price
1	Demolition	LS	1	\$ 10,000.00	\$ 10,000.00
2	Water Service - Corporation, Service Line, Curb Stop, and Box (BY CITY)	LS	1	\$ 4,000.00	\$ 4,000.00
3	Sanitary Service w/drop structure (BY CITY)	LS	1	\$ 4,000.00	\$ 4,000.00
4	Pavement, Sidewalk, 5"	SY	160	\$ 50.00	\$ 8,000.00
5	Modified Subbase, 4"	CY	25	\$ 50.00	\$ 1,250.00

Total \$ 27,250.00

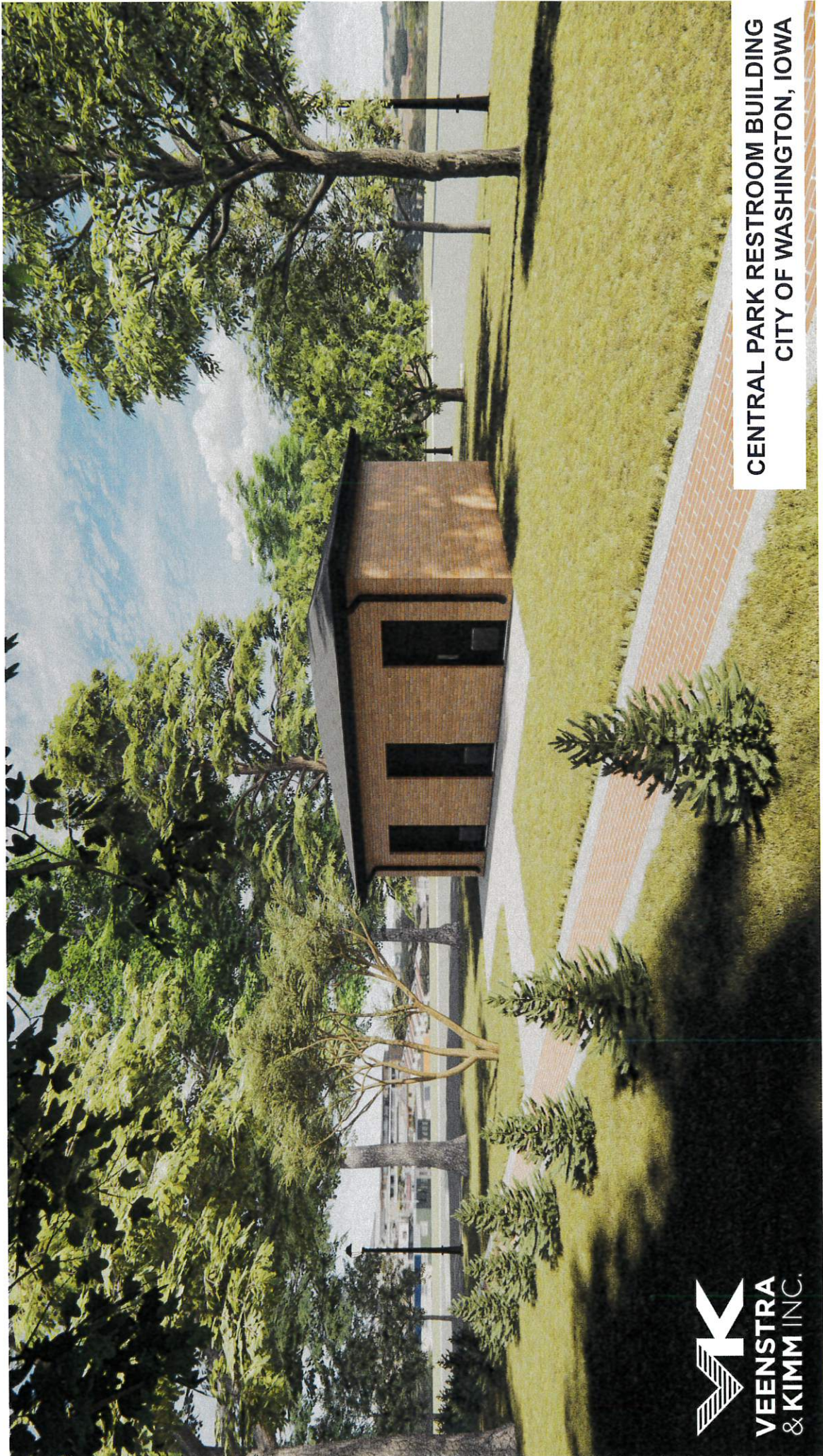

CENTRAL PARK RESTROOM BUILDING
CITY OF WASHINGTON, IOWA

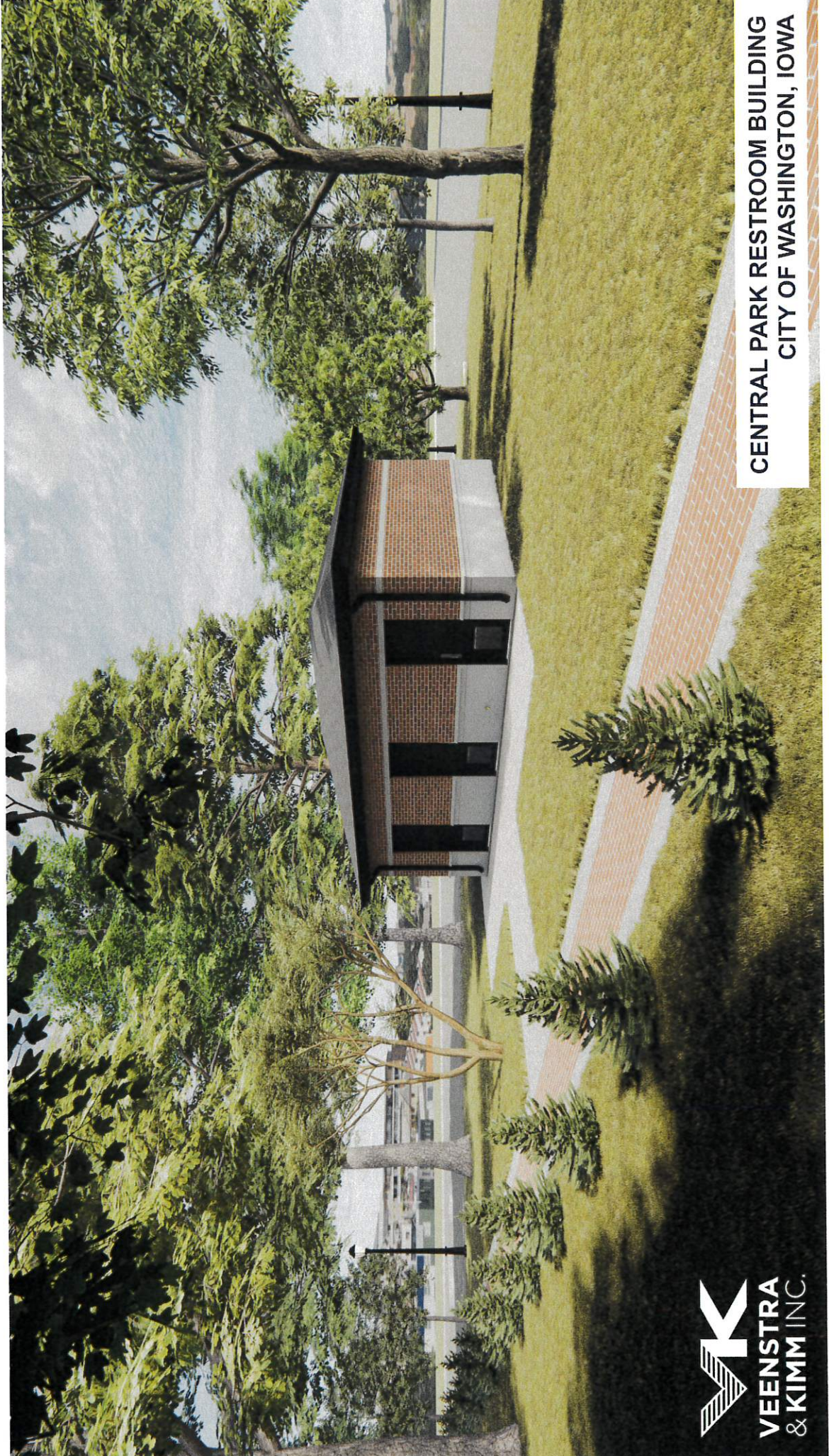

CENTRAL PARK RESTROOM BUILDING
CITY OF WASHINGTON, IOWA

PLANS FOR CENTRAL PARK RESTROOM BUILDING WASHINGTON, IOWA



DRAWING INDEX

NO.	DRAWING TITLE
G-001	INDEX AND TITLE SHEET
G-002	GENERAL NOTES & LEGENDS
G-003	GENERAL NOTES & LEGENDS
C-101	DEMOLITION PLAN
C-102	SITE PLAN
C-103	STAKING DATA
C-104	SITE DETAILS
S-101	FOUNDATION & ROOF FRAMING PLANS
S-102	SECTIONS & DETAILS
S-501	NOTES
A-101	ARCHITECTURAL PLANS
A-201	ELEVATIONS
A-301	SECTIONS & DETAILS
M-101	MECHANICAL HVAC PLAN
P-101	PLUMBING PLUMBING PLAN
E-100	ELECTRICAL ELECTRICAL SITE PLAN
E-101	ELECTRICAL ELECTRICAL SCHEDULES
E-501	ELECTRICAL ELECTRICAL SCHEDULES

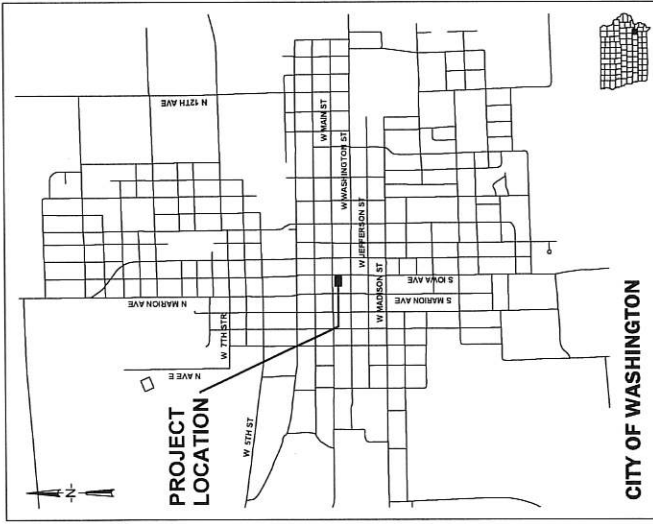

VICINITY MAP
NOT TO SCALE

1-800-292-8989
www.iowacall.com

CENTRAL PARK RESTROOM BUILDING
CITY OF WASHINGTON
3800 University Parkway, Suite 1 • Corvallis, Iowa 52241
319-486-1001 • 319-486-1008(FAX) • 888-241-8001 (WATS)



DATE	REVISIONS	SCALE	J.E.
		DRAWN	
		CHECKED	
		APPROVED	
		DATE	
		DRAWN FOR	

INDEX AND TITLE SHEET		DWG. NO.	PROJECT
G-001		G-001	2403

I HEREBY CERTIFY THAT THE PREPARATION OF THIS TECHNICAL SUBMISSION WAS PREPARED BY ME OR UNDER MY DIRECT PERSONAL SUPERVISION AND THAT I AM A DULY LICENSED ARCHITECT UNDER THE LAWS OF THE STATE OF IOWA.

SIGNATURE: TARA M. GOLDSBERRY
NAME: TARA M. GOLDSBERRY, AIA
LICENSE NUMBER: 072407
MY LICENSE RENEWAL DATE IS: JUNE 30, 2026
PAGES OR SHEETS COVERED BY THIS SEAL: A-101, A-102, A-501

I HEREBY CERTIFY THAT THIS ENGINEERING DOCUMENT WAS PREPARED BY ME OR UNDER MY DIRECT PERSONAL SUPERVISION AND THAT I AM A DULY LICENSED PROFESSIONAL ENGINEER UNDER THE LAWS OF THE STATE OF IOWA.

SIGNATURE: MARK A. HENDERSON
NAME: MARK A. HENDERSON, P.E.
LICENSE NUMBER: 12947
MY LICENSE RENEWAL DATE IS: OCTOBER 31, 2024
PAGES OR SHEETS COVERED BY THIS SEAL: S-101, S-102, S-501

I HEREBY CERTIFY THAT THIS ENGINEERING DOCUMENT WAS PREPARED BY ME OR UNDER MY DIRECT PERSONAL SUPERVISION AND THAT I AM A DULY LICENSED PROFESSIONAL ENGINEER UNDER THE LAWS OF THE STATE OF IOWA.

SIGNATURE: PAVAN N. REDDY
NAME: PAVAN N. REDDY, P.E.
LICENSE NUMBER: 9491
MY LICENSE RENEWAL DATE IS: DECEMBER 31, 2024
PAGES OR SHEETS COVERED BY THIS SEAL: M-101 & P-101

I HEREBY CERTIFY THAT THIS ENGINEERING DOCUMENT WAS PREPARED BY ME OR UNDER MY DIRECT PERSONAL SUPERVISION AND THAT I AM A DULY LICENSED PROFESSIONAL ENGINEER UNDER THE LAWS OF THE STATE OF IOWA.

SIGNATURE: JACOB D. LUCAS
NAME: JACOB D. LUCAS, P.E.
LICENSE NUMBER: 23240
MY LICENSE RENEWAL DATE IS: DECEMBER 31, 2025
PAGES OR SHEETS COVERED BY THIS SEAL: E-101, E-101, E-501

I HEREBY CERTIFY THAT THIS ENGINEERING DOCUMENT WAS PREPARED BY ME OR UNDER MY DIRECT PERSONAL SUPERVISION AND THAT I AM A DULY LICENSED PROFESSIONAL ENGINEER UNDER THE LAWS OF THE STATE OF IOWA.

SIGNATURE: IRLAND J. BELDING, III
NAME: IRLAND J. BELDING, III, P.E.
LICENSE NUMBER: 15046
MY LICENSE RENEWAL DATE IS: DECEMBER 31, 2025
PAGES OR SHEETS COVERED BY THIS SEAL: G-001 THRU G-003, G-101 THRU G-104



FRONT OF BUILDING



REAR OF BUILDING

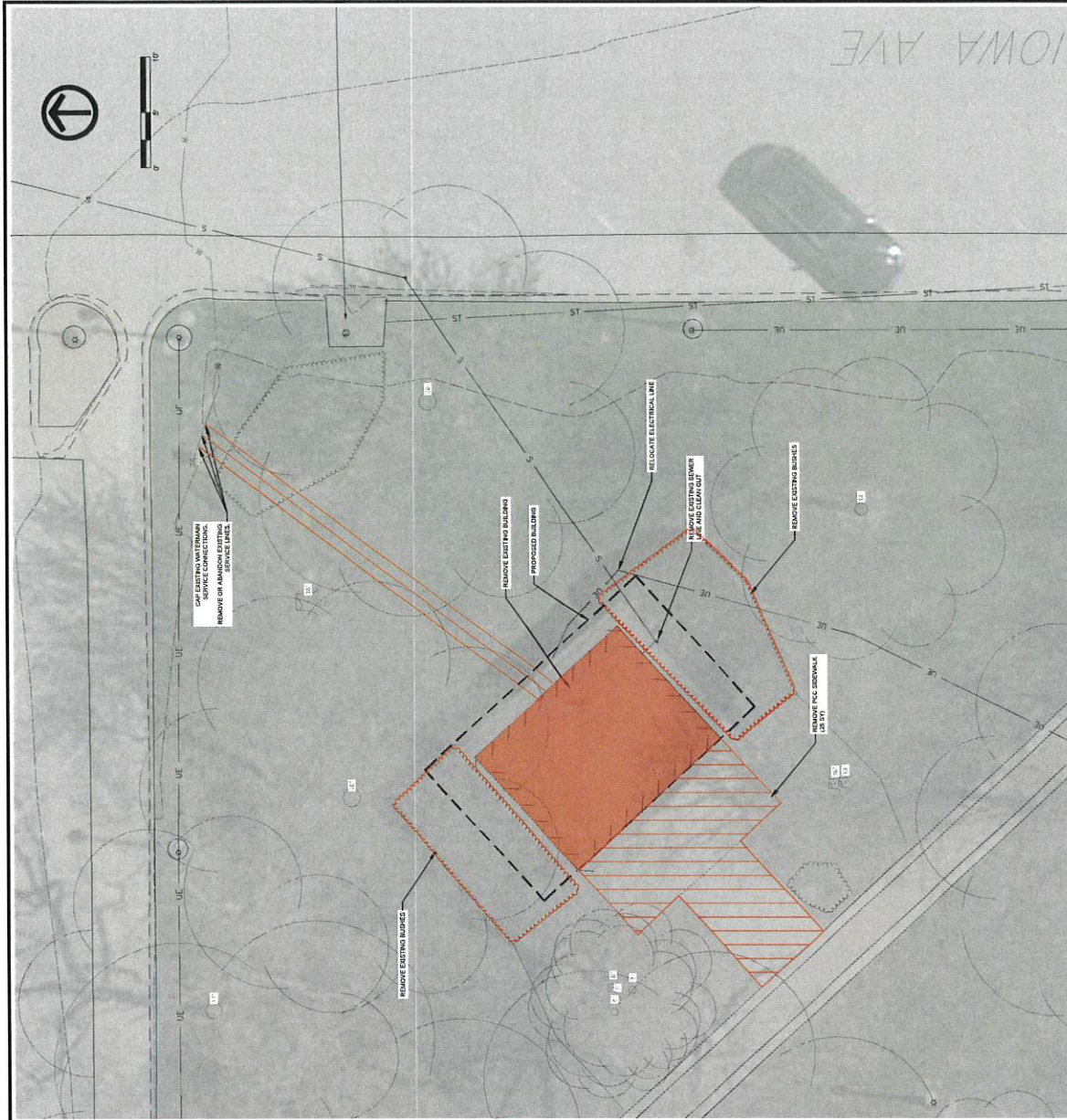

SHEET NO. C-101
PROJECT 24653

DEMOLITION PLAN

CENTRAL PARK RESTROOM BUILDING
CITY OF WASHINGTON
2600 University Parkway, Suite 1 • Coakville, Iowa 52241
319-465-1000 • 319-465-1000(FAX) • 888-241-8001(WATS)



DATE	REVISIONS	SCALE	AS NOTED
		DRAWN	URS
		CHECKED	URS
		DESIGNED	URS
		DATE	24-08-2024
		PROJECT NO.	24653

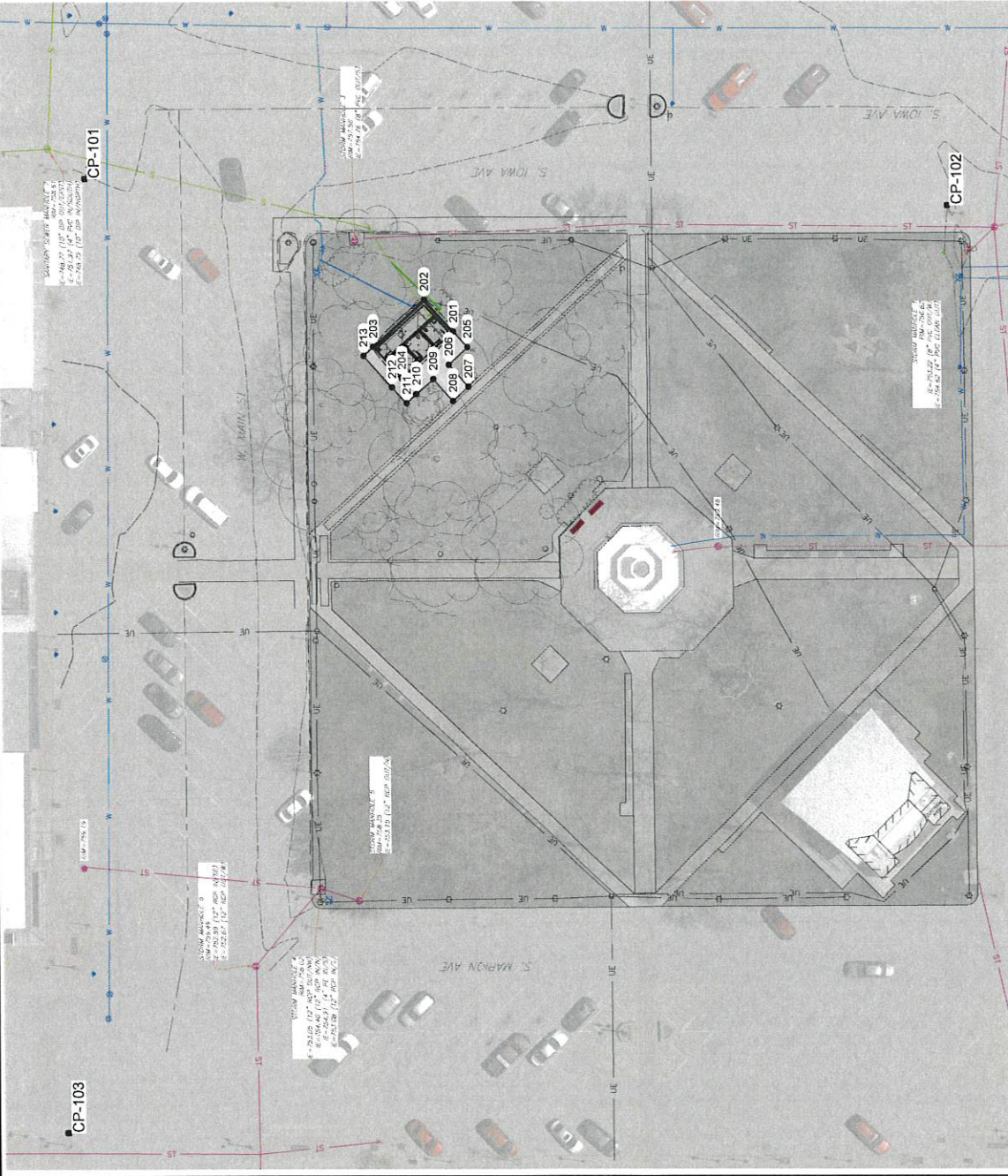

Point #	Run Description	Elevation	Heighting	Existing
1	cp cut x	756.157	478208.724	2137207.7030
201	BLOC	759.000	478489.629	2137160.2713
2	cp cut x	757.099	478282.639	2137187.3326
202	BLOC	759.000	478479.632	2137162.0888
3	cp cut x	756.367	478416.641	2136851.7166
101	cp cut gpn	756.138	478284.727	2137207.6650
102	cp cut gpn	757.160	478282.626	2137187.3360
103	cp cut gpn	756.336	478416.639	2136851.7200
203	BLOC	759.000	478489.632	2137144.6200
204	BLOC	756.000	478488.578	2137132.7451
205	EP	756.880	478383.022	2137144.3860
206	EP	756.880	478470.605	2137137.8450
207	EP	756.650	478483.301	2137129.6284
208	EP	756.648	478489.247	2137174.2899
209	EP	756.880	478476.707	2137132.4533
210	EP	756.880	478482.663	2137136.8531
211	EP	756.880	478486.536	2137123.4827
212	EP	756.025	478481.691	2137138.3427
213	EP	756.025	478602.756	2137141.1931



SHEET NO. C-103
PROJECT 24653

STAKING DATA

CENTRAL PARK RESTROOM BUILDING
CITY OF WASHINGTON
2600 University Parkway, Suite 1 • Columbia, Iowa 52241
319-466-1000 • 319-466-1000(FAX) • 888-241-6001(TWTS)



DATE	REVISIONS	SCALE	AS NOTED
		AS SHOWN	
		AS SHOWN	
		AS SHOWN	
		AS SHOWN	
		AS SHOWN	

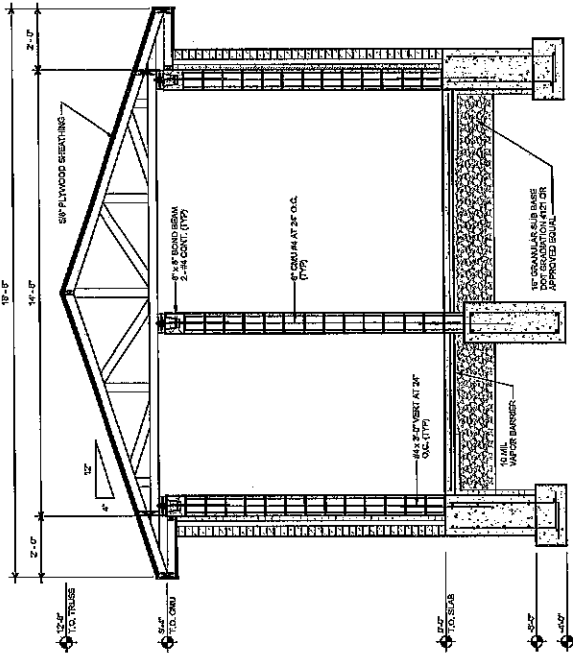

SECTION 1

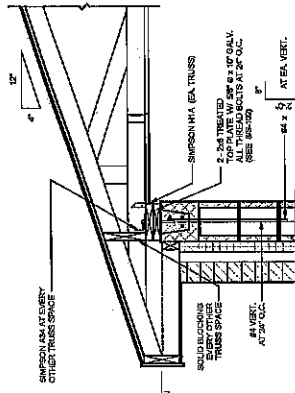

SECTION 2

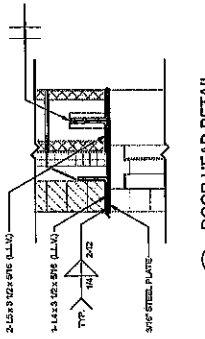

SECTION 3

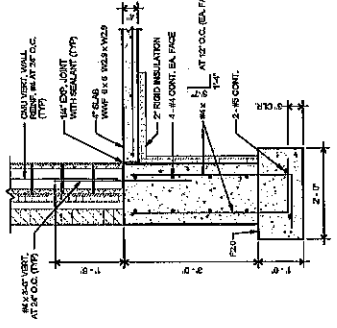

SECTION 4

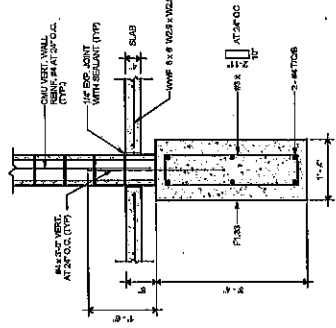

SECTION 5

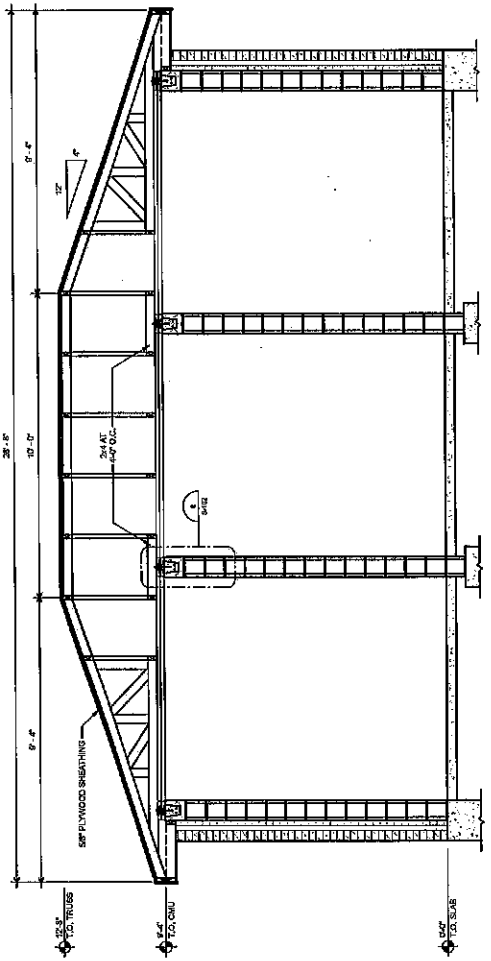

SECTION 6

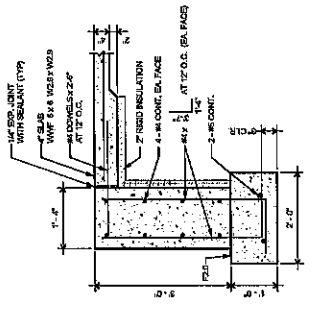

SECTION 7

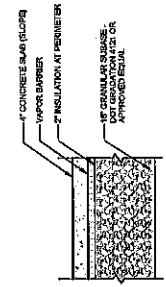

SECTION 8

CENTRAL PARK RESTROOM BUILDING
CITY OF WASHINGTON

SECTIONS & DETAILS

DWG. NO. S-102



2600 University Parkway - Suite 100 • Centreville, VA 20121
315-465-1000 • 315-465-1000/FAX • 588-241-8001 (MATT)

DATE	REVISIONS	BY	DATE

NOTES

CENTRAL PARK RESTROOM BUILDING
 CITY OF WASHINGTON

2000 University Parkway - Scale 1 • Cont./Arch. Issue 5/24/10
 318-495-1007 • 318-495-1009/FAX • 388-5241-4001(M/F/T)

VEENSTRA & KIMMING

DATE	REVISIONS	BY	DATE

DWG. NO. S-501
 PROJECT 2000

GENERAL

THE CONTRACTOR SHALL USE THE SITE TO ENSURE FAMILIARITY WITH EXISTING CONDITIONS AND ALL RELATIONS. COORDINATE BUILDING LAYOUT AND FOUNDATION WORK WITH EXISTING UTILITIES. THE CONTRACTOR SHALL BE RESPONSIBLE FOR OBTAINING ALL NECESSARY PERMITS AND APPROVALS FROM THE CITY OF WASHINGTON. THE CONTRACTOR SHALL BE RESPONSIBLE FOR OBTAINING ALL NECESSARY PERMITS AND APPROVALS FROM THE CITY OF WASHINGTON. THE CONTRACTOR SHALL BE RESPONSIBLE FOR OBTAINING ALL NECESSARY PERMITS AND APPROVALS FROM THE CITY OF WASHINGTON.

FOUNDATIONS

ASSUMED NOT ALLOWABLE SOIL BEARING PRESSURES. SEE PER CONTRACTOR TO RETAIN AND ALL FOUNDATIONS SHALL BE DESIGNED TO BEAT 1000 PSF. ALL FOUNDATIONS SHALL BE DESIGNED TO BEAT 1000 PSF. ALL FOUNDATIONS SHALL BE DESIGNED TO BEAT 1000 PSF. ALL FOUNDATIONS SHALL BE DESIGNED TO BEAT 1000 PSF.

CONCRETE

CONCRETE SHALL BE IN ACCORDANCE WITH IOWA DEPARTMENT OF TRANSPORTATION SPECIFICATIONS. ALL CONCRETE SHALL BE 4000 PSI. ALL CONCRETE SHALL BE 4000 PSI. ALL CONCRETE SHALL BE 4000 PSI. ALL CONCRETE SHALL BE 4000 PSI.

STRUCTURAL WOOD

DESIGN OF APPROVED WOOD TRUSSES AND TRUSS CONNECTIONS SHALL BE BASED ON THE DESIGNER'S SUBMITTED CALCULATIONS AND SHOP DRAWINGS. THE CONTRACTOR SHALL BE RESPONSIBLE FOR OBTAINING ALL NECESSARY PERMITS AND APPROVALS FROM THE CITY OF WASHINGTON. THE CONTRACTOR SHALL BE RESPONSIBLE FOR OBTAINING ALL NECESSARY PERMITS AND APPROVALS FROM THE CITY OF WASHINGTON.

MASONRY

MASSORY CONSTRUCTION SHALL CONFORM TO ACI 318 AND SHALL BE CONSTRUCTED IN ACCORDANCE WITH THE DESIGNER'S SUBMITTED CALCULATIONS AND SHOP DRAWINGS. THE CONTRACTOR SHALL BE RESPONSIBLE FOR OBTAINING ALL NECESSARY PERMITS AND APPROVALS FROM THE CITY OF WASHINGTON. THE CONTRACTOR SHALL BE RESPONSIBLE FOR OBTAINING ALL NECESSARY PERMITS AND APPROVALS FROM THE CITY OF WASHINGTON.

ROOF DRAINAGE

PROFESSIONAL DRAWING SUBMITTED IN THE FORM OF ONE SET OF CONTRACT DOCUMENTS SHALL BE REVIEWED AND SEIGNED BY THE CONTRACTOR. THE CONTRACTOR SHALL BE RESPONSIBLE FOR OBTAINING ALL NECESSARY PERMITS AND APPROVALS FROM THE CITY OF WASHINGTON. THE CONTRACTOR SHALL BE RESPONSIBLE FOR OBTAINING ALL NECESSARY PERMITS AND APPROVALS FROM THE CITY OF WASHINGTON.

MECHANICAL

MECHANICAL SYSTEMS SHALL BE DESIGNED IN ACCORDANCE WITH THE DESIGNER'S SUBMITTED CALCULATIONS AND SHOP DRAWINGS. THE CONTRACTOR SHALL BE RESPONSIBLE FOR OBTAINING ALL NECESSARY PERMITS AND APPROVALS FROM THE CITY OF WASHINGTON. THE CONTRACTOR SHALL BE RESPONSIBLE FOR OBTAINING ALL NECESSARY PERMITS AND APPROVALS FROM THE CITY OF WASHINGTON.

ELECTRICAL

ELECTRICAL SYSTEMS SHALL BE DESIGNED IN ACCORDANCE WITH THE DESIGNER'S SUBMITTED CALCULATIONS AND SHOP DRAWINGS. THE CONTRACTOR SHALL BE RESPONSIBLE FOR OBTAINING ALL NECESSARY PERMITS AND APPROVALS FROM THE CITY OF WASHINGTON. THE CONTRACTOR SHALL BE RESPONSIBLE FOR OBTAINING ALL NECESSARY PERMITS AND APPROVALS FROM THE CITY OF WASHINGTON.

PLUMBING

PLUMBING SYSTEMS SHALL BE DESIGNED IN ACCORDANCE WITH THE DESIGNER'S SUBMITTED CALCULATIONS AND SHOP DRAWINGS. THE CONTRACTOR SHALL BE RESPONSIBLE FOR OBTAINING ALL NECESSARY PERMITS AND APPROVALS FROM THE CITY OF WASHINGTON. THE CONTRACTOR SHALL BE RESPONSIBLE FOR OBTAINING ALL NECESSARY PERMITS AND APPROVALS FROM THE CITY OF WASHINGTON.

MECHANICAL TRUSS DESIGN AND REDUCTIONS

MECHANICAL TRUSS DESIGN AND REDUCTIONS SHALL BE IN ACCORDANCE WITH THE DESIGNER'S SUBMITTED CALCULATIONS AND SHOP DRAWINGS. THE CONTRACTOR SHALL BE RESPONSIBLE FOR OBTAINING ALL NECESSARY PERMITS AND APPROVALS FROM THE CITY OF WASHINGTON. THE CONTRACTOR SHALL BE RESPONSIBLE FOR OBTAINING ALL NECESSARY PERMITS AND APPROVALS FROM THE CITY OF WASHINGTON.

MECHANICAL TRUSS DESIGN AND REDUCTIONS

MECHANICAL TRUSS DESIGN AND REDUCTIONS SHALL BE IN ACCORDANCE WITH THE DESIGNER'S SUBMITTED CALCULATIONS AND SHOP DRAWINGS. THE CONTRACTOR SHALL BE RESPONSIBLE FOR OBTAINING ALL NECESSARY PERMITS AND APPROVALS FROM THE CITY OF WASHINGTON. THE CONTRACTOR SHALL BE RESPONSIBLE FOR OBTAINING ALL NECESSARY PERMITS AND APPROVALS FROM THE CITY OF WASHINGTON.

MECHANICAL TRUSS DESIGN AND REDUCTIONS

MECHANICAL TRUSS DESIGN AND REDUCTIONS SHALL BE IN ACCORDANCE WITH THE DESIGNER'S SUBMITTED CALCULATIONS AND SHOP DRAWINGS. THE CONTRACTOR SHALL BE RESPONSIBLE FOR OBTAINING ALL NECESSARY PERMITS AND APPROVALS FROM THE CITY OF WASHINGTON. THE CONTRACTOR SHALL BE RESPONSIBLE FOR OBTAINING ALL NECESSARY PERMITS AND APPROVALS FROM THE CITY OF WASHINGTON.

MECHANICAL TRUSS DESIGN AND REDUCTIONS

MECHANICAL TRUSS DESIGN AND REDUCTIONS SHALL BE IN ACCORDANCE WITH THE DESIGNER'S SUBMITTED CALCULATIONS AND SHOP DRAWINGS. THE CONTRACTOR SHALL BE RESPONSIBLE FOR OBTAINING ALL NECESSARY PERMITS AND APPROVALS FROM THE CITY OF WASHINGTON. THE CONTRACTOR SHALL BE RESPONSIBLE FOR OBTAINING ALL NECESSARY PERMITS AND APPROVALS FROM THE CITY OF WASHINGTON.

MECHANICAL TRUSS DESIGN AND REDUCTIONS

MECHANICAL TRUSS DESIGN AND REDUCTIONS SHALL BE IN ACCORDANCE WITH THE DESIGNER'S SUBMITTED CALCULATIONS AND SHOP DRAWINGS. THE CONTRACTOR SHALL BE RESPONSIBLE FOR OBTAINING ALL NECESSARY PERMITS AND APPROVALS FROM THE CITY OF WASHINGTON. THE CONTRACTOR SHALL BE RESPONSIBLE FOR OBTAINING ALL NECESSARY PERMITS AND APPROVALS FROM THE CITY OF WASHINGTON.

MECHANICAL TRUSS DESIGN AND REDUCTIONS

MECHANICAL TRUSS DESIGN AND REDUCTIONS SHALL BE IN ACCORDANCE WITH THE DESIGNER'S SUBMITTED CALCULATIONS AND SHOP DRAWINGS. THE CONTRACTOR SHALL BE RESPONSIBLE FOR OBTAINING ALL NECESSARY PERMITS AND APPROVALS FROM THE CITY OF WASHINGTON. THE CONTRACTOR SHALL BE RESPONSIBLE FOR OBTAINING ALL NECESSARY PERMITS AND APPROVALS FROM THE CITY OF WASHINGTON.

MECHANICAL TRUSS DESIGN AND REDUCTIONS

MECHANICAL TRUSS DESIGN AND REDUCTIONS SHALL BE IN ACCORDANCE WITH THE DESIGNER'S SUBMITTED CALCULATIONS AND SHOP DRAWINGS. THE CONTRACTOR SHALL BE RESPONSIBLE FOR OBTAINING ALL NECESSARY PERMITS AND APPROVALS FROM THE CITY OF WASHINGTON. THE CONTRACTOR SHALL BE RESPONSIBLE FOR OBTAINING ALL NECESSARY PERMITS AND APPROVALS FROM THE CITY OF WASHINGTON.

MECHANICAL TRUSS DESIGN AND REDUCTIONS

MECHANICAL TRUSS DESIGN AND REDUCTIONS SHALL BE IN ACCORDANCE WITH THE DESIGNER'S SUBMITTED CALCULATIONS AND SHOP DRAWINGS. THE CONTRACTOR SHALL BE RESPONSIBLE FOR OBTAINING ALL NECESSARY PERMITS AND APPROVALS FROM THE CITY OF WASHINGTON. THE CONTRACTOR SHALL BE RESPONSIBLE FOR OBTAINING ALL NECESSARY PERMITS AND APPROVALS FROM THE CITY OF WASHINGTON.

MECHANICAL TRUSS DESIGN AND REDUCTIONS

MECHANICAL TRUSS DESIGN AND REDUCTIONS SHALL BE IN ACCORDANCE WITH THE DESIGNER'S SUBMITTED CALCULATIONS AND SHOP DRAWINGS. THE CONTRACTOR SHALL BE RESPONSIBLE FOR OBTAINING ALL NECESSARY PERMITS AND APPROVALS FROM THE CITY OF WASHINGTON. THE CONTRACTOR SHALL BE RESPONSIBLE FOR OBTAINING ALL NECESSARY PERMITS AND APPROVALS FROM THE CITY OF WASHINGTON.

ROOM FINISH SCHEDULE

ROOM NO.	ROOM NAME	AREA	FLOOR FINISH	BASE FINISH	CEILING FINISH	N	E	W	REMARKS
00	MEDIA	224.58	CS	N/A	FP	CS	CS	CS	
01	RESTROOM	24.58	CS	N/A	FP	CS	CS	CS	
02	RESTROOM	24.58	CS	N/A	FP	CS	CS	CS	
03	RESTROOM	24.58	CS	N/A	FP	CS	CS	CS	
04	RESTROOM	24.58	CS	N/A	FP	CS	CS	CS	
05	RESTROOM	24.58	CS	N/A	FP	CS	CS	CS	

DOOR SCHEDULE

NO.	SIZE	FRAME TYPE	DOOR TYPE	MATERIAL	DOOR	REMARKS
1	2'-0" X 7'-0"	D-1	D-1	NM4	NM4	FINISHED WITH LAMINATE
2	2'-0" X 7'-0"	D-1	D-1	NM4	NM4	FINISHED WITH LAMINATE
3	2'-0" X 7'-0"	D-1	D-1	NM4	NM4	FINISHED WITH LAMINATE
4	2'-0" X 7'-0"	D-1	D-1	NM4	NM4	FINISHED WITH LAMINATE
5	1'-0" X 7'-0"	D-1	D-1	NM4	NM4	FINISHED WITH LAMINATE
6	1'-0" X 7'-0"	D-1	D-1	NM4	NM4	FINISHED WITH LAMINATE

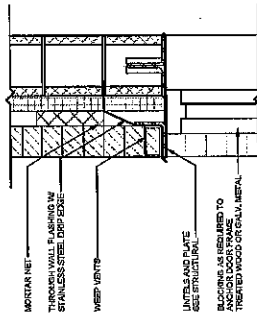
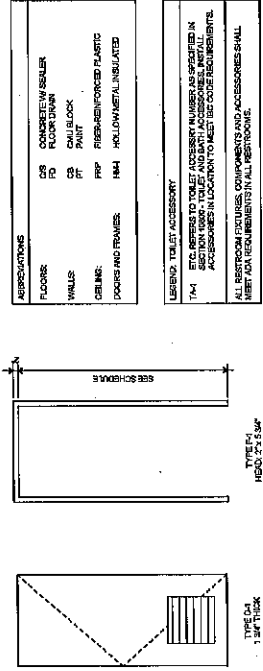

2. DOOR HEAD DETAIL

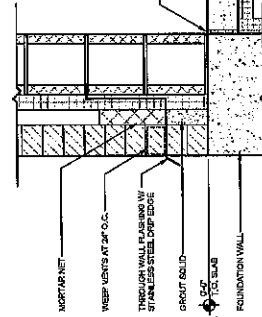

3. WALL BASE DETAIL

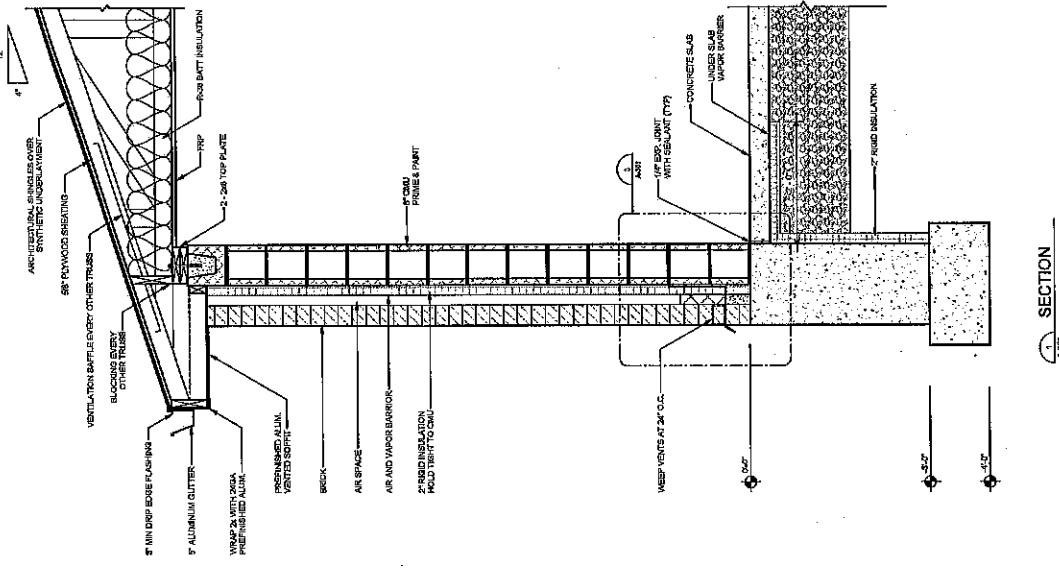

1. SECTION

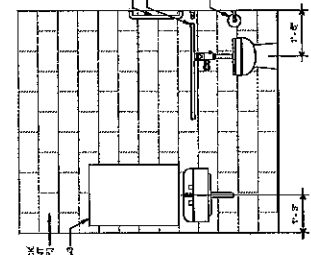

4. INTERIOR ELEVATION

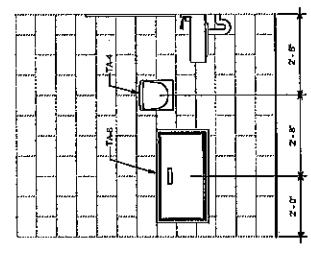

5. INTERIOR ELEVATION

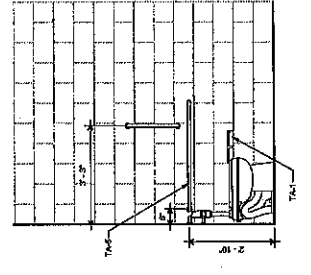

6. INTERIOR ELEVATION

VEENSTRA & KIMM INC.

2800 University Parkway, Suite 101 • Costa Mesa, Iowa 52001
319-469-1001 • 319-469-1002(FAX) • 888-241-8001 (TOLL FREE)

CENTRAL PARK RESTROOM BUILDING
CITY OF WASHINGTON

SECTIONS & DETAILS

DRWG. NO. **A-301**

PROJECT **24883**

DATE	REVISIONS	SCALE	DATE	BY	CHKD	DATE	BY	CHKD

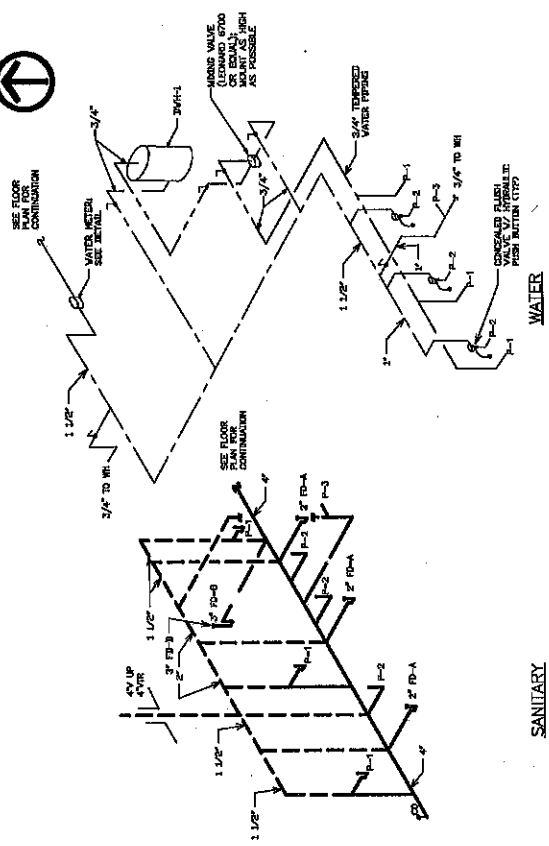

SANITARY

WATER

PLUMBING ISOMETRICS

NO SCALE

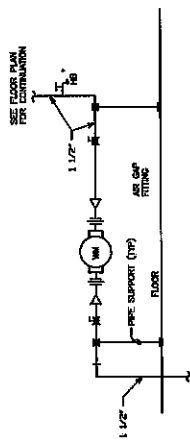

WATER METER DETAIL

NO SCALE

500

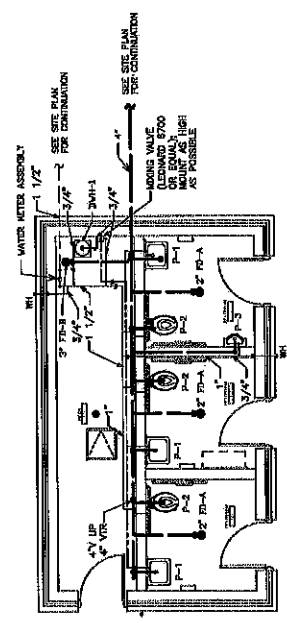

FLOOR PLAN
SCALE 1/4" = 1'-0"

PLUMBING FIXTURE SCHEDULE

NO.	DESCRIPTION	MANUFACTURER / MODEL NO.	TEMP.	SOIL	VENT	CM	HW	NOTES
1	WATER METER ASSEMBLY	WEST	1 1/2"	2	1 1/2"	1 1/2"	1 1/2"	1, 2
2	WATER METER ASSEMBLY	WEST	1 1/2"	2	1 1/2"	1 1/2"	1 1/2"	1, 2
3	WATER METER ASSEMBLY	WEST	1 1/2"	2	1 1/2"	1 1/2"	1 1/2"	1, 2
4	WATER METER ASSEMBLY	WEST	1 1/2"	2	1 1/2"	1 1/2"	1 1/2"	1, 2

1. FINISH WITH INTERIOR WALL MOUNTED ABOVE URINAL. 2. FINISH WITH INTERIOR WALL MOUNTED ABOVE URINAL. 3. FINISH WITH INTERIOR WALL MOUNTED ABOVE URINAL. 4. FINISH WITH INTERIOR WALL MOUNTED ABOVE URINAL.

FLOOR DRAIN SCHEDULE

NO.	DESCRIPTION	MANUFACTURER / MODEL NO.	FINISH	NOTES
1	FLOOR DRAIN	WEST	SMOOTH	1
2	FLOOR DRAIN	WEST	SMOOTH	2

1. FINISH WITH INTERIOR WALL MOUNTED ABOVE URINAL. 2. FINISH WITH INTERIOR WALL MOUNTED ABOVE URINAL.

INSULATION SCHEDULE

NO.	DESCRIPTION	MANUFACTURER / MODEL NO.	TEMP.	SOIL	VENT	CM	HW	NOTES
1	INSULATION	WEST	1 1/2"	2	1 1/2"	1 1/2"	1 1/2"	1, 2

DOMESTIC WATER HEATER SCHEDULE

NO.	DESCRIPTION	MANUFACTURER / MODEL NO.	TEMP.	SOIL	VENT	CM	HW	NOTES
1	DOMESTIC WATER HEATER	WEST	1 1/2"	2	1 1/2"	1 1/2"	1 1/2"	1, 2



CENTRAL PARK RESTROOM BUILDING
CITY OF WASHINGTON
2500 University Parkway, Suite 1 • Columbia, Iowa 52621
319-466-1000 • 319-466-1099(FAX) • 319-241-5001(MOBILE)

DWG. NO. P-101
PROJECT OF 2-889

PLUMBING PLAN

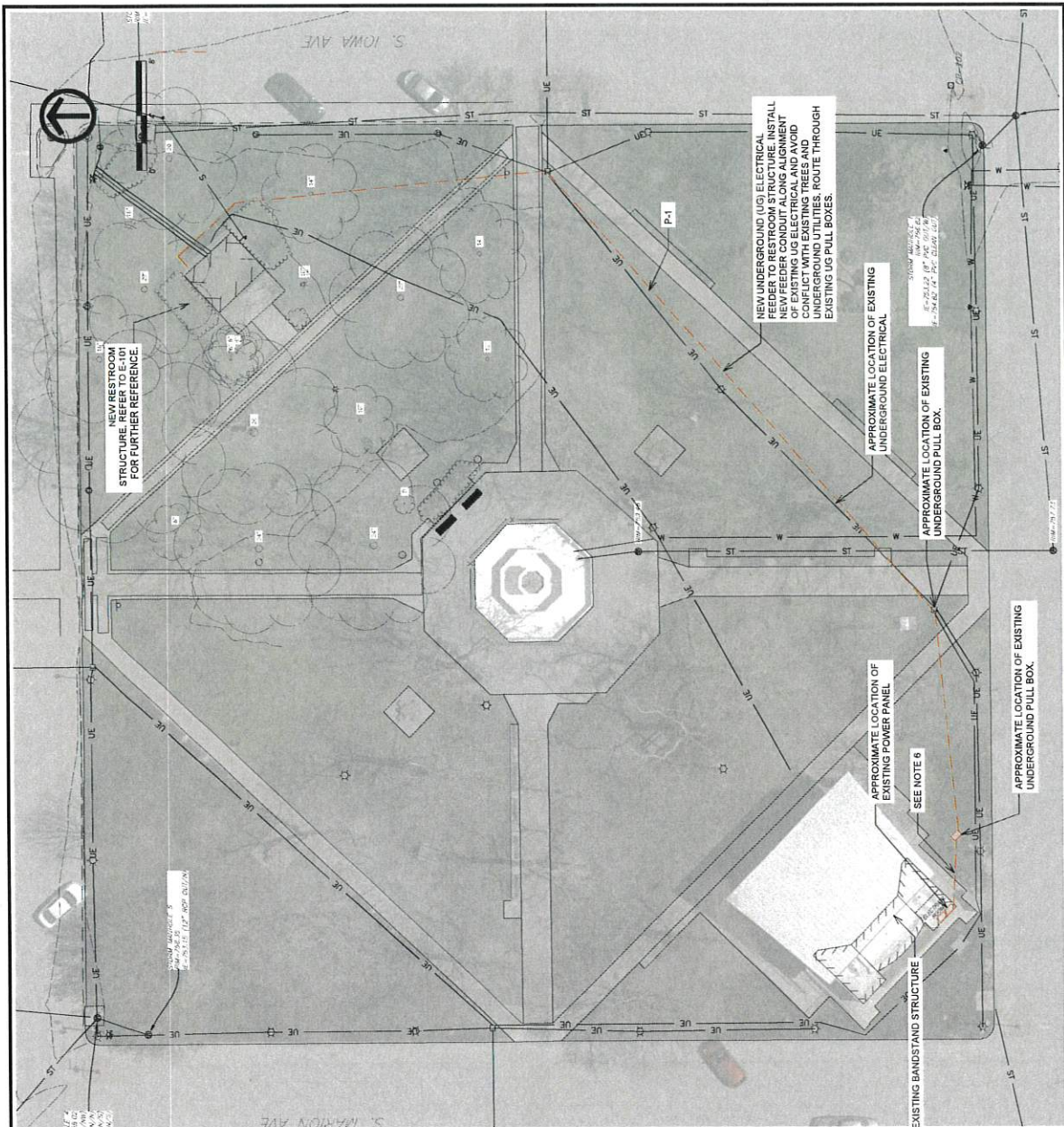

- GENERAL NOTES:**
1. DO NOT SCALE DRAWINGS. IF DIMENSIONS ARE IN QUESTION THE CONTRACTOR SHALL BE RESPONSIBLE FOR OBTAINING CLARIFICATION FROM THE ENGINEER PRIOR TO PROCEEDING WITH WORK.
 2. ALL EXTERIOR RACEWAYS THAT EXTEND FROM BELOW GRADE TO ABOVE GRADE SHALL BE INSTALLED WITH EXPANSION COLLAR SLEEVES.
 3. UNDERGROUND CONDUIT ROUTING IS DIAGNOSTIC IN NATURE AND IS NOT INTENDED TO DICTATE FIELD CONDITIONS. CONTRACTOR IS TO DETERMINE BEST ROUTING BASED ON OTHER UTILITIES AND FIELD CONDITIONS.
 4. CONTRACTOR SHALL FURNISH UNDERGROUND PULL BOXES AS NECESSARY FOR A COMPLETE INSTALLATION.
 5. AVOID CONDUIT PENETRATIONS ON TOP OF WALL-MOUNTED PANELS, WHERE FEASIBLE.
 6. CONTRACTOR SHALL UTILIZE EXISTING CONDUIT FROM POWER DISTRIBUTION PANEL TO SERVE NEW RESTROOM STRUCTURE. CONTRACTOR SHALL BE RESPONSIBLE TO REMOVE AND REPLACE EXISTING UNDERGROUND ELECTRICAL FROM FIRST EXISTING PULL BOX TO NEW RESTROOM STRUCTURE.

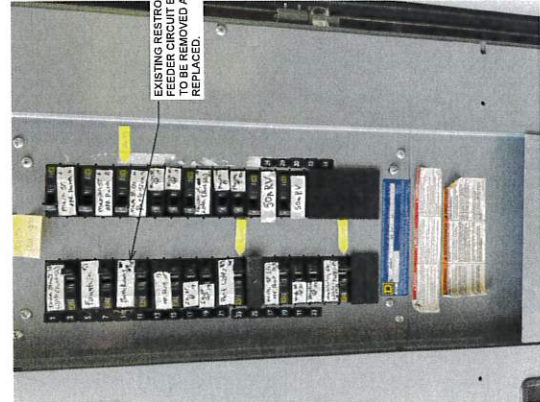

EXISTING POWER DISTRIBUTION PANEL
NO SCALE

	CENTRAL PARK RESTROOM BUILDING CITY OF WASHINGTON	SHEET NO. E-100
2659 University Parkway, Suite 1 • Coralville, Iowa 52241 319-465-1000 • 319-466-1008(FAX) • 888-241-8001(WATS)		PROJECT 24653

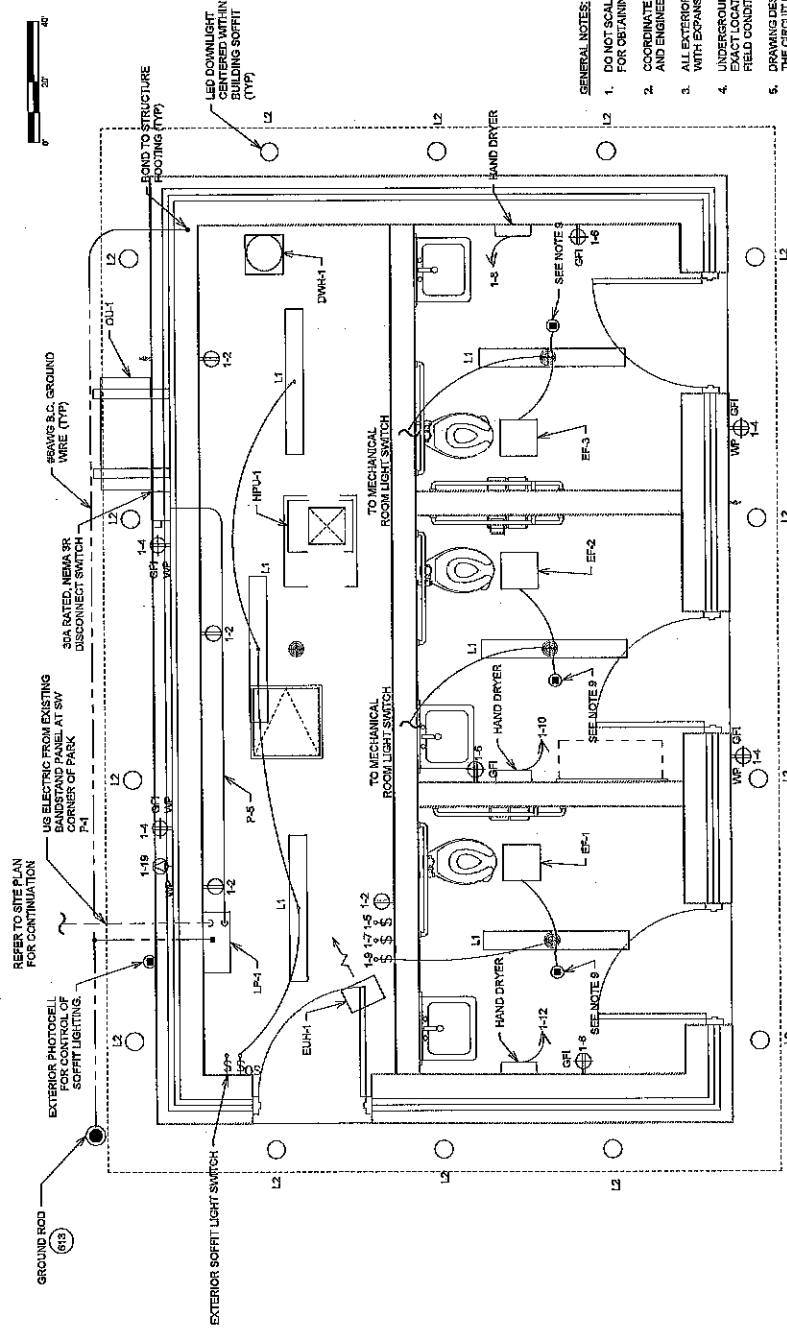

GENERAL NOTES:

1. DO NOT SCALE DRAWINGS. IF DIMENSIONS ARE IN QUESTION THE CONTRACTOR SHALL BE RESPONSIBLE FOR OBTAINING CLARIFICATION FROM THE ENGINEER PRIOR TO PROCEEDING WITH WORK.
2. COORDINATE EXACT LOCATION OF EQUIPMENT AND FIXTURES WITH GENERAL CONTRACTOR, OWNER AND ENGINEER PRIOR TO ROUGH-IN.
3. ALL EXTERIOR RACEWAYS THAT EXTEND FROM BELOW GRADE TO ABOVE GRADE SHALL BE INSTALLED WITH EXPANSION COLLAR SLEEVES.
4. UNDERGROUND CONDUIT ROUTING IS DIAGRAMMATIC IN NATURE AND IS NOT INTENDED TO DICTATE EXACT LOCATIONS. CONTRACTOR IS TO DETERMINE BEST ROUTING BASED ON OTHER UTILITIES AND FIELD CONDITIONS.
5. DRAWING DESIGNATIONS FOR LIGHTING PANEL LP-1 CIRCUITS ARE AS FOLLOWS, WITH X REPRESENTING THE CIRCUIT NUMBER: 1-X.
6. AVOID CONDUIT PENETRATIONS ON TOP OF EXTERIOR WALL-MOUNTED PANELS, WHERE FEASIBLE.
7. INTERIOR WIRING DEVICES SHALL BE MOUNTED AT 48" AFF., UNLESS OTHERWISE NOTED. EXTERIOR RECEPTACLES SHALL BE MOUNTED AT 36" AS., AND FURNISHED WITH LOCKABLE WEATHERPROOF IN-JOB COVER.
8. ALL CONDUITS AND WIRING RUNS MAY NOT BE SHOWN. PROVIDE 3/4" CONDUIT AND 2#12 & 1#12 G. TO ALL EQUIPMENT LOADS IDENTIFIED, UNLESS SCHEDULED OTHERWISE.
9. OCCUPANCY SENSORS. RESTROOM LIGHTING SHALL BE CONTROLLED BASED ON ROOM OCCUPANCY.

SHEET NO. E-101
PROJECT 2443

ELECTRICAL PLAN

CENTRAL PARK RESTROOM BUILDING
CITY OF WASHINGTON
2000 University Parkway, Suite 1 • Crystal Lake, IL 60014
312-486-1000 • 312-486-1000/FAX • 312-486-1000/CELL



DATE	REVISIONS	SCALE	AS SHOWN	DATE	BY	CHK	APP	DATE	BY	CHK	APP

LP-1 - MECHANICAL ROOM
 120V/240VOLT, 1 PHASE, 3 WIRE
 MECHANICAL ROOM LOAD

NO.	DESCRIPTION	AMPS	VOLTS	WATTS	VA	WIRE SIZE	TERMINALS	CONDUIT	NOTES
1	3000W, 120V, 15A	15	120	1800	2250	12	1	1/2"	1
2	3000W, 120V, 15A	15	120	1800	2250	12	1	1/2"	1
3	3000W, 120V, 15A	15	120	1800	2250	12	1	1/2"	1
4	3000W, 120V, 15A	15	120	1800	2250	12	1	1/2"	1
5	3000W, 120V, 15A	15	120	1800	2250	12	1	1/2"	1
6	3000W, 120V, 15A	15	120	1800	2250	12	1	1/2"	1
7	3000W, 120V, 15A	15	120	1800	2250	12	1	1/2"	1
8	3000W, 120V, 15A	15	120	1800	2250	12	1	1/2"	1
9	3000W, 120V, 15A	15	120	1800	2250	12	1	1/2"	1
10	3000W, 120V, 15A	15	120	1800	2250	12	1	1/2"	1
11	3000W, 120V, 15A	15	120	1800	2250	12	1	1/2"	1
12	3000W, 120V, 15A	15	120	1800	2250	12	1	1/2"	1
13	3000W, 120V, 15A	15	120	1800	2250	12	1	1/2"	1
14	3000W, 120V, 15A	15	120	1800	2250	12	1	1/2"	1
15	3000W, 120V, 15A	15	120	1800	2250	12	1	1/2"	1
16	3000W, 120V, 15A	15	120	1800	2250	12	1	1/2"	1
17	3000W, 120V, 15A	15	120	1800	2250	12	1	1/2"	1
18	3000W, 120V, 15A	15	120	1800	2250	12	1	1/2"	1
19	3000W, 120V, 15A	15	120	1800	2250	12	1	1/2"	1
20	3000W, 120V, 15A	15	120	1800	2250	12	1	1/2"	1
21	3000W, 120V, 15A	15	120	1800	2250	12	1	1/2"	1
22	3000W, 120V, 15A	15	120	1800	2250	12	1	1/2"	1
23	3000W, 120V, 15A	15	120	1800	2250	12	1	1/2"	1
24	3000W, 120V, 15A	15	120	1800	2250	12	1	1/2"	1
25	3000W, 120V, 15A	15	120	1800	2250	12	1	1/2"	1
26	3000W, 120V, 15A	15	120	1800	2250	12	1	1/2"	1
27	3000W, 120V, 15A	15	120	1800	2250	12	1	1/2"	1
28	3000W, 120V, 15A	15	120	1800	2250	12	1	1/2"	1
29	3000W, 120V, 15A	15	120	1800	2250	12	1	1/2"	1
30	3000W, 120V, 15A	15	120	1800	2250	12	1	1/2"	1

PLA 1005 WCA 2713

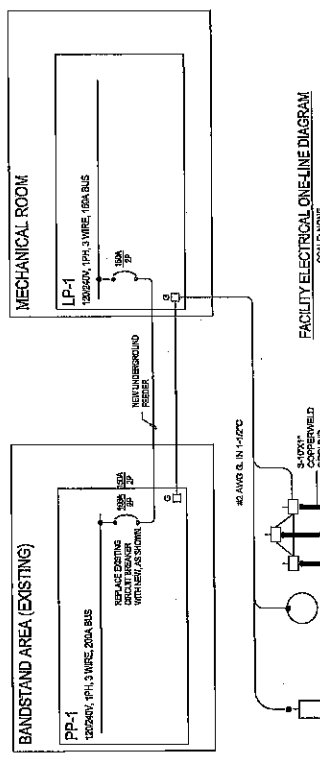

LIGHT FIXTURE SCHEDULE

PLANT ID	BASES OF DESIGN	FIXTURE DATA	VOLTAGE	NOTES
L1	KIDWALL MOUNTED 4" R/W APP. BLANK LOG 100 OR EQUAL	40W LED LINEAR FIXTURE, SURFACE MOUNT 300K, WHITE FINISH	100	2, 3
L2	PROSCOUTE LIT LEDS 4" X 16" 4K LIPS OR EQUAL	15W LED, 4' DOWNLIGHT, 1100 LUMEN, STAINLESS STEEL, TRIM, WEST LOCATION PAINTED	120	1, 2, 3
E1	LITRONAL LIT MOUNTED R-10 OR EQUAL	LED OUTLINE TRANSFORMER LUMENS	120	2, 3

NOTES:
 1. FURNISH FIXTURE WITH PHOTO CELL & MOTION SENSOR AND WIRE IN SERIES WITH SWITCH, WIRE SHOWN, FURNISH WITH REMOTE CONTROL, ACCESSORY.
 2. SHALL BE DESIGNED TO OPERATE IN COLD TEMPERATURES.
 3. FURNISH WITH MOUNTING HARDWARE

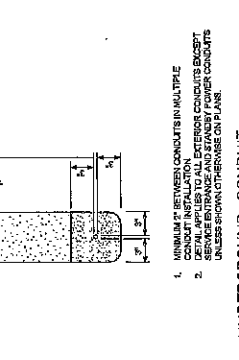
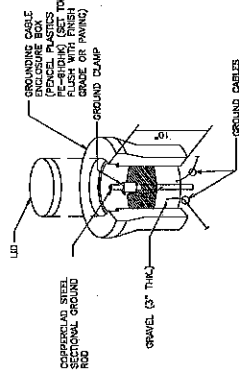

POWER WIRING SCHEDULE

CONDUIT	CONDUIT SIZE	CONDUIT TYPE	FROM	TO	NOTES
P-1	2"	SWD & TRB O.L.	BANDSTAND PANEL	LP-1	1, 2
P-2	3/4"	SWD & TRB O.L.	LP-1	SPECIAL USE REC.	1
P-3	3/4"	SWD & TRB O.L.	LP-1	BP-1	1
P-4	3/4"	SWD & TRB O.L.	LP-1	BP-1	1
P-5	3/4"	SWD & TRB O.L.	LP-1	CP-1	1

NOTES:
 1. ALL "P" CONDUITS MAY NOT BE SHOWN ON DRAWINGS. ROUTE CONDUITS AND WIRING AS PER THE SCHEDULE.
 2. REPLACE EXISTING CONDUIT CONNECTION AT POWER PANEL WITH SCHEDULED FEEDER CIRCUIT.

VEENSTRA & KIMM INC.
 2000 University Parkway, Suite 1 • Coralville, Iowa 52241
 319-665-1000 • 319-665-1000(FAX) • 888-241-8901(VOICEMAIL)

REVISIONS

NO.	DATE	BY	CHKD.	APP'D.	DATE	REVISION

DATE: _____

CENTRAL PARK RESTROOM BUILDING
 CITY OF WASHINGTON

ELECTRICAL SCHEDULES AND DETAILS

SHEET NO. E-501
 PROJECT: _____
 2025



*Millie Youngquist, Mayor
Joe Gaa, City Administrator
Kelsey Brown, Finance Director
Kevin Olson, City Attorney*

*City of Washington
215 East Washington Street
Washington, Iowa 52353
(319) 653-6584 Phone
(319) 653-5273 Fax*

MEMORANDUM

TO: Mayor and City Council

FROM: Joe Gaa, City Administrator

A handwritten signature in blue ink, appearing to be "JG", is written over the name "Joe Gaa" in the "FROM" field.

DATE: September 13, 2024

SUBJECT: Proposed Second Reading Amending (Additions) Chapter 69

At the September 3rd Council Meeting the City Council approved the first reading of an ordinance amending Chapter 69. The amendment adds additional no parking zones in certain locations around the City. The second reading of the ordinance amending Chapter 69 has been place on the September 17th Council Agenda. There have been no additional public comments since the first reading. Staff recommends that the Council approve the second reading of the ordinance revision on September 17th.

If you have any questions or comments regarding this matter, feel free to contact me at your convenience.

ORDINANCE NO. _____

**AN ORDINANCE AMENDING THE MUNICIPAL CODE OF THE
CITY OF WASHINGTON, IOWA, BY AMENDING CHAPTER
69.08, "NO PARKING ZONES"**

BE IT ORDAINED by the City Council that the Code of Ordinances of the City of Washington, Iowa be amended as follows:

SECTION 1. **Added Paragraphs.** Section 69.08 "No Parking Zones", the following paragraphs are added as follows:

116. West Van Buren on the north side from South Iowa Avenue west to South Avenue C.

117. South Avenue B, on both sides from Tyler Street to Sitler Drive, from 7:00am to 4:30pm on school days.

118. East Second Street, on the south side for 85 feet east from the centerline with North Fourth Avenue.

119. East Second Street, on the north side from North Third Avenue to North Sixth Avenue.

120. East Main Street, on both sides for 40 feet west of the intersection with Fourth Avenue.

121. East Main Street, on the south side for 144 feet east from the centerline with North Fourth Avenue and on the north side from North Fourth Avenue east to North Sixth Avenue.

122. North Marion Avenue on both sides from West 8th Street north to West 15th Street.

SECTION 2. **Repealer.** All ordinances or parts of ordinances in conflict with the provisions of this Ordinance are hereby repealed.

SECTION 3. **Severability.** If any section, provision or part of this ordinance shall be judged invalid or unconstitutional, such adjudication shall not affect the validity of the ordinance as a whole or any section, provision or part thereof not adjudged invalid or unconstitutional.

SECTION 4. **Effective Date.** This Ordinance shall be in effect after its final passage, approval and publication as provided by law.

Passed and approved this _____ day of _____, 2024.

Millie Youngquist, Mayor

Attest:

Kelsey Brown, Deputy City Clerk

Approved on First Reading: September 3, 2024
Approved on Second Reading: _____
Approved on Third & Final Reading: _____

I certify that the foregoing was published as Ordinance No. _____ on the _____ day
of _____, 2024.

Kelsey Brown, Deputy City Clerk

*Millie Youngquist, Mayor
Joe Gaa, City Administrator
Kelsey Brown, Finance Director
Kevin Olson, City Attorney*



*City of Washington
215 East Washington Street
Washington, Iowa 52353
(319) 653-6584 Phone
(319) 653-5273 Fax*

Memorandum

September 13, 2024

To: Mayor and City Council

From: Kelsey Brown
Finance Director

Re: Resolution to Levy Taxes – 815 North 8th Avenue

This discussion item is requested to levy taxes against the above property due to unpaid utility charges. This customer was sent a final bill on April 15, 2024, and 3 subsequent notices following. Finally, a written was sent informing the property owner that this amount would be submitted to the Washington County Treasurer for tax assessment if payment was not made.

Please let me know if you have any questions regarding this matter.

RESOLUTION 2024-_____

**A RESOLUTION AUTHORIZING LEVY,
ASSESSMENT, AND COLLECTION OF COSTS TO THE
WASHINGTON COUNTY TREASURER**

WHEREAS, the City of Washington, Iowa, is empowered to levy, assess, and collect costs of improvement for water service charges that remain unpaid and delinquent for the following listed property owner:

The property of Kevin McDole at 815 North 8th Avenue for the amount of \$413.34. Legal Description (02 21 Columbian Add). Parcel Number (1117212006).

WHEREAS, due notice was given to the above property owner that said amount would be assessed to the property if payment was not made or an appeal was not made.

NOW, THEREFORE, BE IT RESOLVED BY THE COUNCIL OF THE CITY OF WASHINGTON, IOWA, that the City Clerk be instructed to certify the above delinquent payment to be assessed against said property as listed above and that the City Clerk certify a copy of this Resolution to the Washington County Treasurer.

PASSED AND APPROVED this 17th day of September, 2024.

Millie Youngquist, Mayor

ATTEST:

Kelsey Brown, Deputy City Clerk

Millie Youngquist, Mayor
Joe Gaa, City Administrator
Kelsey Brown, Finance Director
Kevin Olson, City Attorney



City of Washington
215 East Washington Street
Washington, Iowa 52353
(319) 653-6584 Phone
(319) 653-5273 Fax

MEMORANDUM

TO: Mayor and City Council

FROM: Joe Gaa, City Administrator 

DATE: September 13, 2024

SUBJECT: Discussion and 1st Reading of Ordinance Amending Chapters 50 and 51

At the September 3rd meeting the Council continued discussion related to possible amendments to Chapter 50 and 51. At that time the first reading was tabled until the September 17th Council meeting to allow for further review. After further discussion, I do believe that we have a version that is an appropriate balance to both property owners and neighbors.

As a reminder, Chapter 50.10 in the City code currently reads:

“Operable vehicles, materials, supplies or related equipment may be parked or stored outside only if placed in a rear yard area, or in a front yard or side yard if such vehicle is parked or stored on a temporary basis, not to exceed 24 consecutive hours, and if the vehicle is parked or stored on an all -weather surfaced area.”

The proposed amended definition is included in the attached, proposed ordinance amendment:

“50.10 Parking on Residential Property. Operable vehicles may be parked on a temporary basis, not to exceed 24 consecutive hours in a front yard area of a residence. Operable vehicles parked or stored more than 24 hours must be parked on an all-weather surface and only in a rear yard or side yard.”

This amendment has been placed on the September 17th meeting for a first reading. If you have any questions or comments regarding this matter, feel free to contact me at your convenience.

ORDINANCE NO. ____

AN ORDINANCE AMENDING THE MUNICIPAL CODE OF THE CITY OF WASHINGTON, IOWA, BY AMENDING CHAPTERS 50 AND 51

BE IT ORDAINED by the City Council that the Code of Ordinances of the City of Washington, Iowa be amended as follows:

SECTION 1. Amendment. Section 50.10 entitled "Operable Vehicles" is hereby repealed in its entirety and replaced with the following:

"50.10 PARKING ON RESIDENTIAL PROPERTY. Operable vehicles may be parked on a temporary basis, not to exceed 24 consecutive hours in a front yard area of a residence. Operable vehicles parked or stored more than 24 hours must be parked on an all-weather surface and only in a rear yard or side yard."

SECTION 2. Amendment. Section 51.01(5) of the Code of Ordinances is hereby amended by adding subsections F. and G, which read as follows:

"F" Any vehicle, trailer, or semitrailer that is not capable of moving in both forward and reverse gears.

"G." Any vehicle, trailer, or semitrailer that lacks current registration.

- i. Mere licensing of a vehicle shall not constitute a defense to the finding that the vehicle is in operable condition, unless previously discussed with the City."

SECTION 3. Amendment. Section 51.03 of the Code of Ordinances is hereby amended by deleting Section 51.03 in its entirety.

SECTION 4. Repealer. All ordinances or parts of ordinances in conflict with the provisions of this Ordinance are hereby repealed.

SECTION 5. Adjudication. If any section, provision, or part of this ordinance shall be adjudged to be invalid or unconstitutional, such adjudication shall not affect the validity of the ordinance as a whole or any section, provision or part thereof not adjudged invalid or unconstitutional.

SECTION 6. Effective Date. This Ordinance shall be in effect after its final passage, approval and publication as provided by law.

Passed and approved this ____ day of _____, 2024.

Millie Youngquist, Mayor

Attest:

Kelsey Brown, Deputy City Clerk

Approved on First Reading: _____

Approved on Second Reading: _____

Approved on Third & Final Reading: _____

I certify that the foregoing was published as Ordinance No. ___ on the ___ day of
_____, 2024.

Kelsey Brown, Deputy City Clerk